

LONGMILL

LongMill MK2.5 Assembly Manual

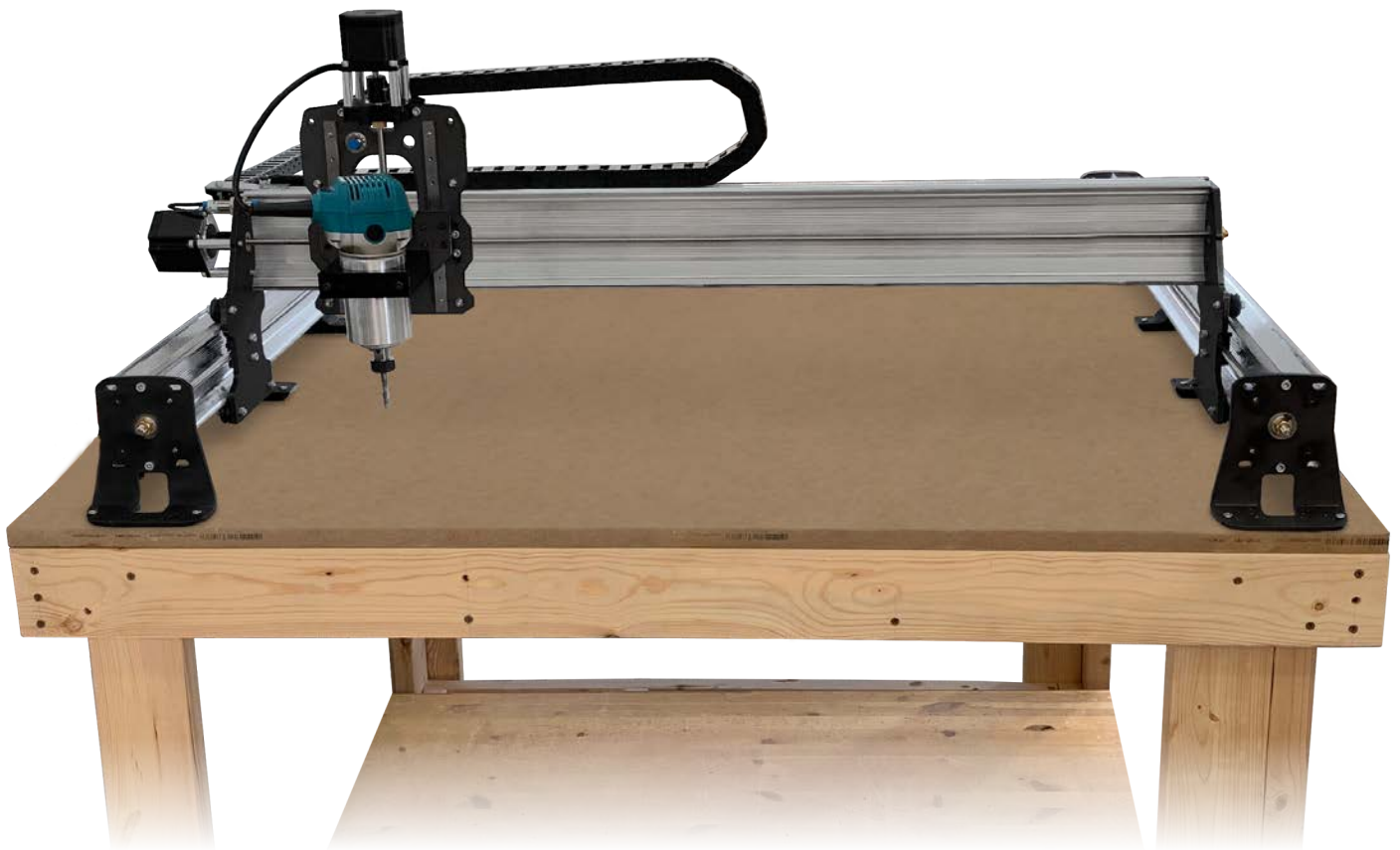

MK2.5



SIENCI LABS
IDEAS INTO REALITY

Table of Contents

| | | |
|----------------|---------------------------------|--------------|
| Part 0: | Welcome to CNC | pg 3 |
| Part 1: | X & Z-Axes | pg 7 |
| Part 2: | Y-Axis Gantries | pg 21 |
| Part 3: | Axes Completion | pg 34 |
| Part 4: | Motors & Wiring | pg 43 |
| Part 5: | Checks & First Moves | pg 61 |
| Part 6: | Table Mounting | pg 81 |
| Part 7: | 48" X-axis Assembly | pg 94 |

Welcome to CNC

Hey there!

So you got yourself a LongMill MK2.5 desktop CNC. Congratulations!

So, now what? Here's everything you should know before you start building your machine.

Please read this whole section before continuing on with assembly. It will provide you with the startup information and context needed to have a smooth and successful assembly.

What to expect

Diving into your LongMill box you'll be met with a whole lot of boxes within. This assembly manual is laid out in a way that you unbag and grab things as you need them so don't feel the need to take stock of everything right away, instead just start off by getting your space organized and getting each initial box opened up.

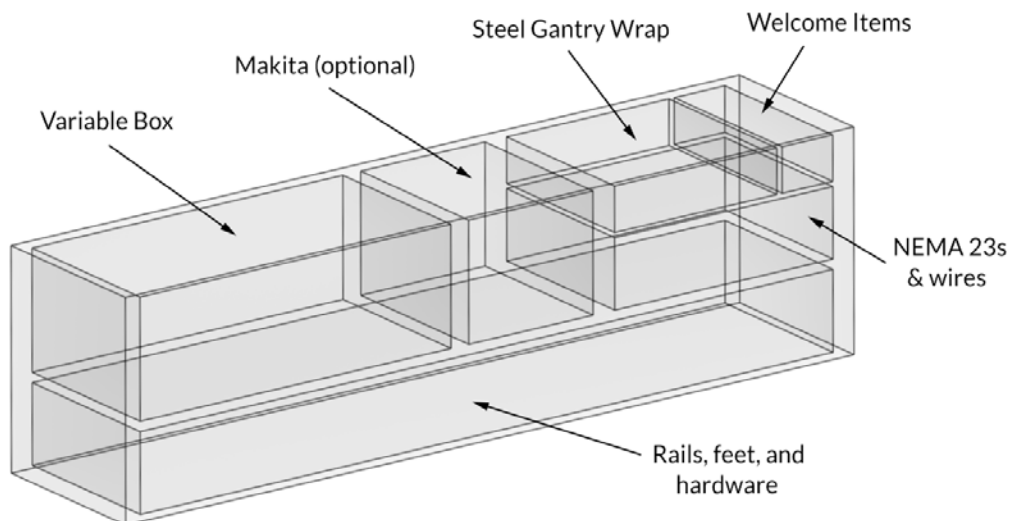

Check out the 'welcome items' where you'll find our letter alongside some tools provided for assembly and some fun stickers. Also check out the 'variable box' and 'rail box' for extra goodies, some are hidden within the rails themselves. Set aside items like the Makita and NEMA23 motor box as well any add-ons from the variable box like bits, dust shoe, touch plate, since you won't need these until much later on in the assembly.

If you've ordered the 48x30 size LongMill, you'll receive a second 'EX Rail Box' which is further discussed in [section B - EX rail box unpacking](#) in the 48" axis assembly manual.

Look out for this symbol:  which indicates that you'll need to follow a few different steps outlined in this accompanying manual. If you aren't assembling a 48x30 LongMill MK2.5 you can ignore these callouts.

Tools you'll need

You'll need these tools on hand for assembly. Most people will have these in their shop:

- Metric Allen keys (we provide)
- Metric wrenches (we provide) or a metric socket set
- A small flat head screwdriver
- A red robertson driver or bit (optional if using the wood screws we provide)

We provide a specialized 'LongMill wrench' and the needed Allen keys to help complete your assembly and act as dedicated maintenance tools once your machine is in operation. We don't recommend you use an impact driver for assembly except when mounting the machine because you won't save much time and some assemblies are prone to damage if they're overtightened

Missing/broken parts?

Don't sweat it - your kit has spares and redundancy included. If a part is lost or isn't going together how you expect, no worries; just check through the bags and you'll likely find what you need to continue assembly. Expect a pile of bolts left over at the end and feel free to set these aside for future machine maintenance.

We supply extra parts so that:

- If a part doesn't work properly the extra one can be used instead
- If you lose something (especially small things) you don't have to search the floor
- You can more easily upgrade to a larger LongMill model at a later date
- We reduce the chance of packing too few on our end

If a part is missing completely, check that you're looking for the right thing and ensure you look through all the packaging you received with your LongMill. Some parts and add-ons such as the t-tracks ship in a separate package if they can't fit into the box for the main kit.

If a part arrives broken and doesn't have a spare, the LongMill's warranty covers replacement parts and we'll even be happy to help you out if you break it yourself. Just shoot us a message here (<https://sienci.com/contact-us/>) and see if there are any other areas of assembly you can continue with in the meantime. We'll get back to you as soon as we can.

Assembly tips

1. Take breaks when needed

The assembly process can take a few to several hours. Pace yourself and enjoy the process - after all, you are learning CNC as a hobby!

2. Read the instructions

Many issues during assembly can be solved by re-examining the instructions. Check that you didn't skip a page and that you completed the previous step correctly. Some steps are hard to explain and some parts have names that are hard to remember so looking at the pictures more closely can also help you to better understand what needs to be done. Reading is encouraged if you'd like more detail on where to locate the part, what function it serves on the machine, and other elaborative information.

Our assembly videos can't be updated as often as the online or PDF instructions so if packaging or parts change the written manual will always be able to clarify these changes.

3. Remember the language

This manual contains some technical language as well as a distinct visual language. Keeping these in mind will make the assembly easier for you to understand and ensure that less mistakes happen.

- Section title pages: show the part of the machine you'll be working on next



- Transparent parts: outlined in blue with a blue arrow path to show where the part starts and where it ends up



- Rotation arrows: come as either blue or red, blue indicating a loose placement of the part and red indicating a firm tightening required to fasten the part into place



- Caution triangles: marks something that requires attention



- Large green circles: provide a secondary view of the current step for added clarity

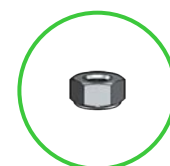

- X, Y, and Z: during assembly if you see these capitalized letters used it's because we refer to some parts by the axis they belong to. For reference, if you're looking at the LongMill from the front the X-axis is when the machine moves left/right, the Y-axis is towards/away from you, and the Z-axis is moving up/down from the tabletop

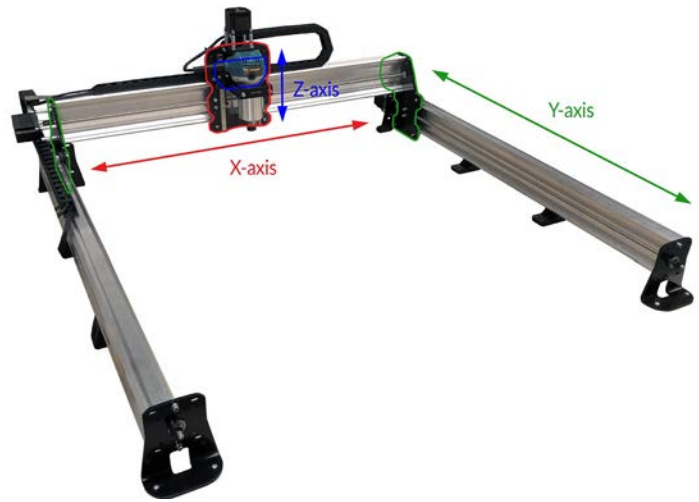

4. Connect with the community

If you are looking to get quick advice or to share your excitement about the LongMill, post in our [forum](#) or [Facebook group](#)! We have a large and friendly group of CNC enthusiasts who enjoy engaging in conversations and sharing their CNC experiences.

Final words

You've got this! We want you to succeed and have designed this machine to give you a great CNC experience while not requiring much experience or assembly accuracy from you. Thousands of people have been in the same shoes as you, starting off as CNC beginners who eventually find their way through.

We've got many resources at your disposal on our site and amongst our community. Be curious, take it easy and you'll soon be teaching everyone your new craft :)

Part 1
X & Z-Axes

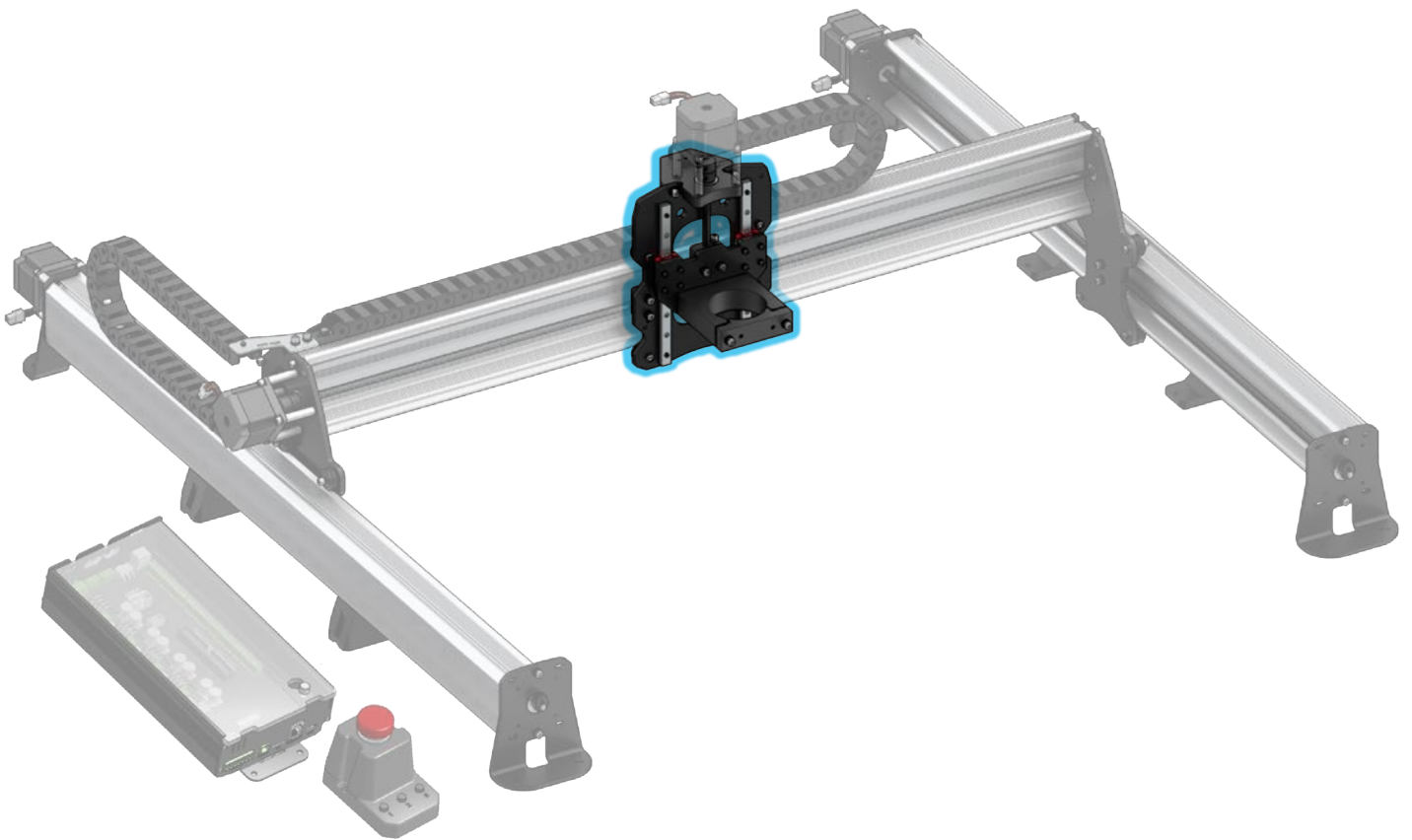

Nut Assembly

Parts Needed:



x8

M5-Nylock Nuts

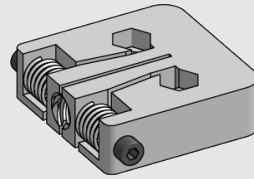

x4

T8 Spring loaded anti-backlash nut

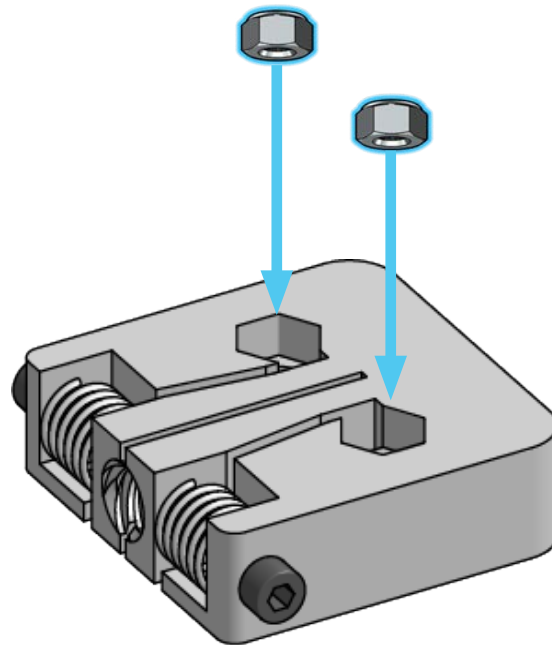

Now, find bags labeled for 'M5-nylock nuts', (there should only be 4 or 5 in the bag), and the final one which contains some large rectangular plastic blocks. These are called 'T8 spring loaded anti-backlash nuts', and you'll see later how they work to give your CNC movement and keep it accurate.

Start by pressing the M5-nylock nuts into the hexagonal cutouts in the plastic blocks. It'll be tempting to face the round part of the nut downwards for easier installation, but these have to actually face upward out of the plastic so that they can be properly bolted on later. It may require some force to push the nuts into the cutouts - feel free to use pliers, one of the steel plates, a vise, or anything else to get them in-place as long as you're careful to take your time. You'll need 4 blocks, set aside spares as extra.

With four blocks ready, set them aside.

Z-axis Motor Mount

Parts Needed:

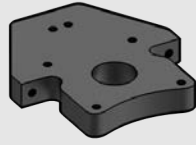

Z-axis motor mount



x2

608ZZ flange bearing

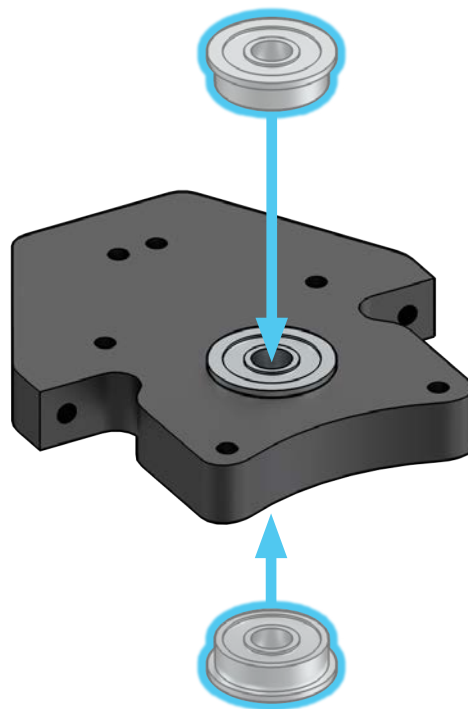

First you'll want to get your Z-axis motor mount from where it would've been kept with the rest of the cutting tools and add-ons, we call this box the 'variable box'. It'll be a wrapped aluminum part similar in size to the router mount.

We will start with the hardware bag marked with a green sticker - dump the contents out. This hardware is most of what's needed for the first half of assembly so you can assume that hardware comes from here unless mentioned otherwise.

With the motor mount in hand you'll also want to get the bag with bearings in it, of which you'll need two for now. Press these into both sides of the bore on the Z-axis motor mount. You should be able to assemble these easily with your thumbs.

Z-axis Mount Sub-assembly

Parts Needed:



6.35mm to 8mm
coupler



200mm lead screw

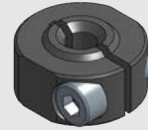

T8 clamping ACME
nut

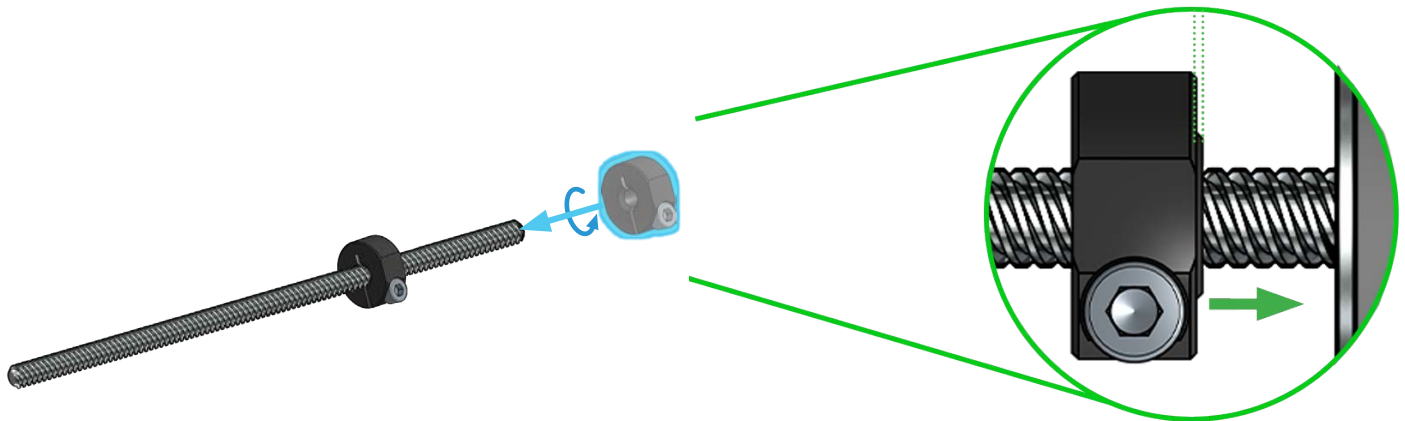

Going back to the parts, you'll want to look for the short lead screw which will be packaged alongside the other, longer lead screws. This step will also use a locking ACME nut and a coupler from the bag of couplers. Grab the ACME nut and thread a couple inches (as pictured) onto the lead screw. Make sure the ACME nut still has its set screw.

Please Note: There is a small bump coming out of one side of the clamping nut, that will need to face towards the short side of the lead screw.

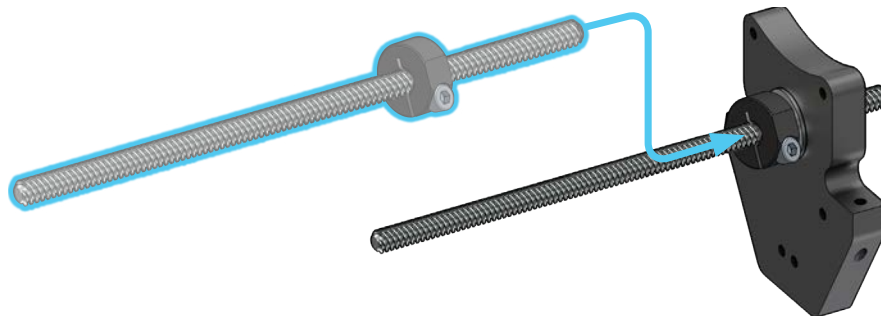

Next, slide the short end of the lead screw through the bearings on the Z-axis motor mount. This fit may be tight so just do your best to hold everything in place and try to wiggle the lead screw or tap it with a mallet if needed. Make sure the bearings are sitting straight in the bore before applying force.

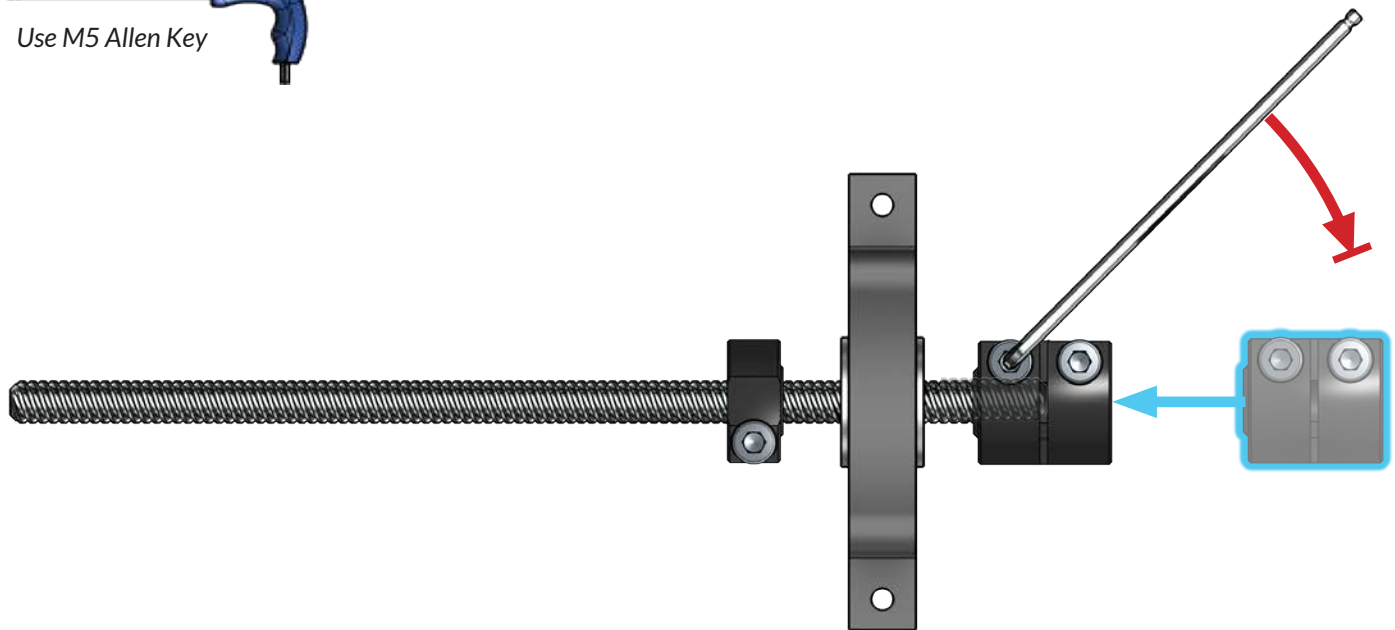

On the coupler, identify the end with the larger hole - this will be the only side that fits onto the lead screw. Push the coupler on until it bottoms out, then tighten the 'lead screw side' set screw using an M5 Allen key. **BEWARE!** Only tighten ONE of the set screws - the one on the lead screw side (as pictured). You'll tighten the other set screw near the end of machine assembly. If you overtighten the wrong set screw it can deform your coupler and cause assembly issues.

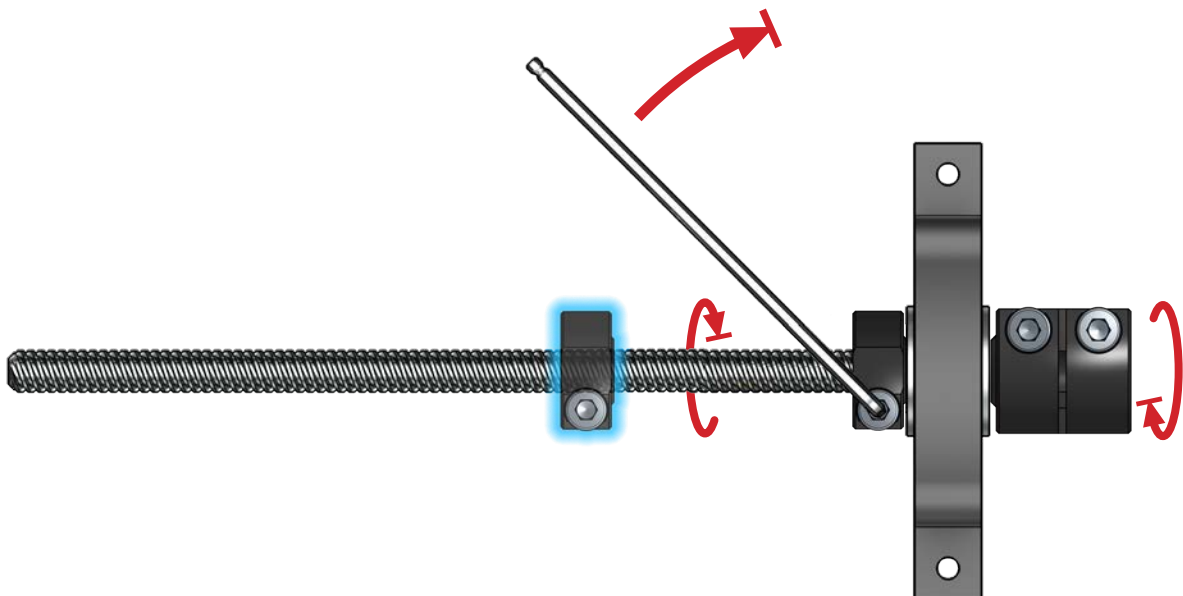

Now rotate the coupler and ACME nut in opposite directions so that they come together to clamp onto the two bearings. Once they're together, making a 'bolted sandwich', everything should be touching (as pictured). Once in this position, tighten the set screw on the locking ACME nut. If assembled properly, this should now feel like a solid, single piece where the lead screw should only be allowed to rotate, and not move in-and-out. Set this assembly aside for now.

XZ-axis Gantry Sub-assembly

Parts Needed:

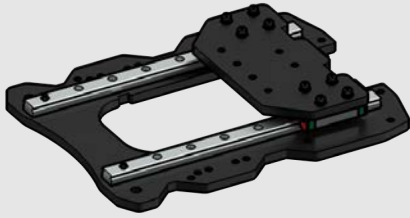

XZ-gantry assembly



V-wheel



M5-25mm bolt

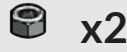

M5-nylock nut



Eccentric nut



M5 washer



From the green bag, grab the 'M5 washers', 'M5-25mm bolts' and the 'Delrin V-wheels'. If the v-wheels have an off-centered ring in the middle (pictured), use the small Allen key to move the ring back to the center.

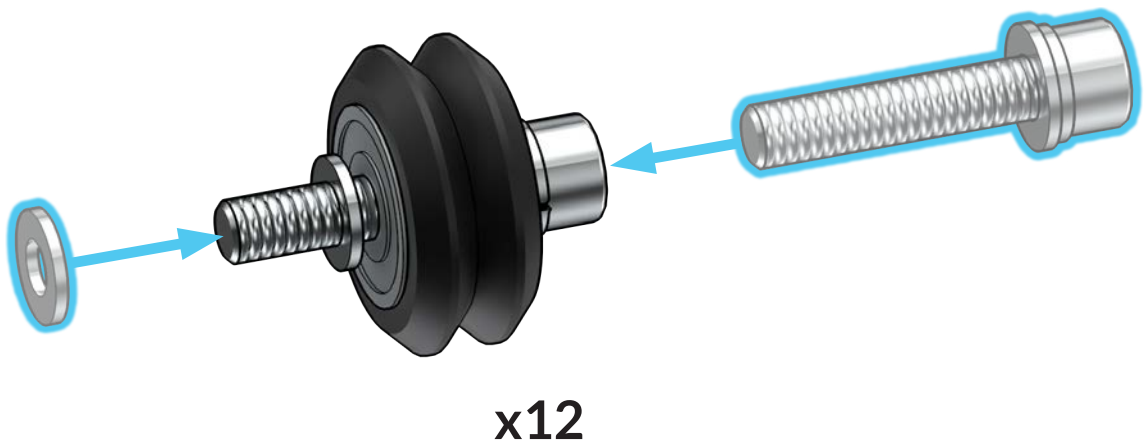

Using all 12 v-wheels, put the bolts through each with a washer on the other end. Ensure the washer is in the correct place, because this keeps the wheel from rubbing against the gantry and provides the correct spacing between the gantry and the lead screw.

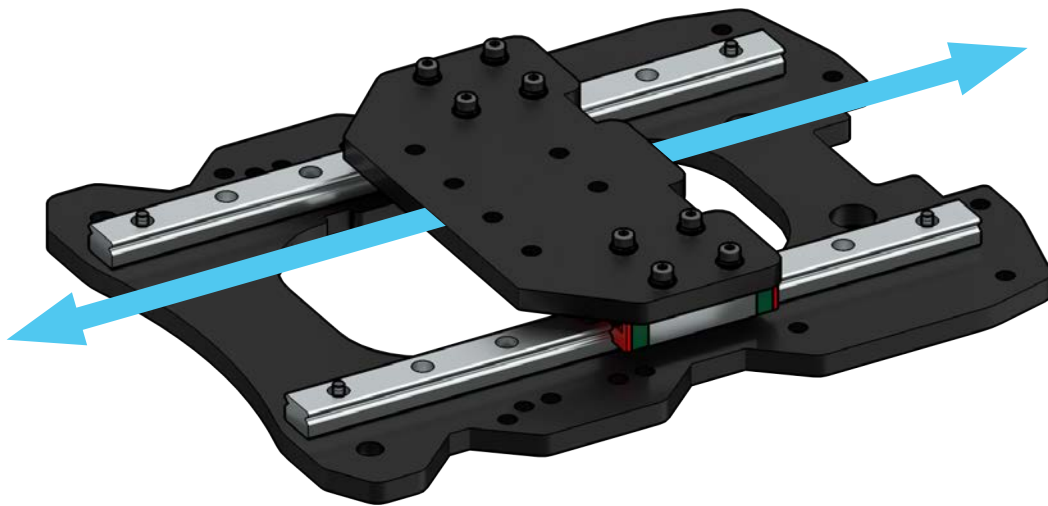

You should now find the XZ-gantry assembly among the cardboard wrap of the steel gantries. This looks like a smaller steel plate (Z-gantry) attached to a larger steel plate (X-gantry) via two sliding rails (pictured). First, check the movement of the Z-gantry by moving it up and down with your hand. The motion should be smooth, and there should not be any binding. The existing bolts going into the front and back of the plates should also already be reasonably secure but not fully torqued down.

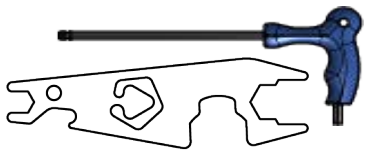

Use Wrench & M5 Allen Key



Rails facing down

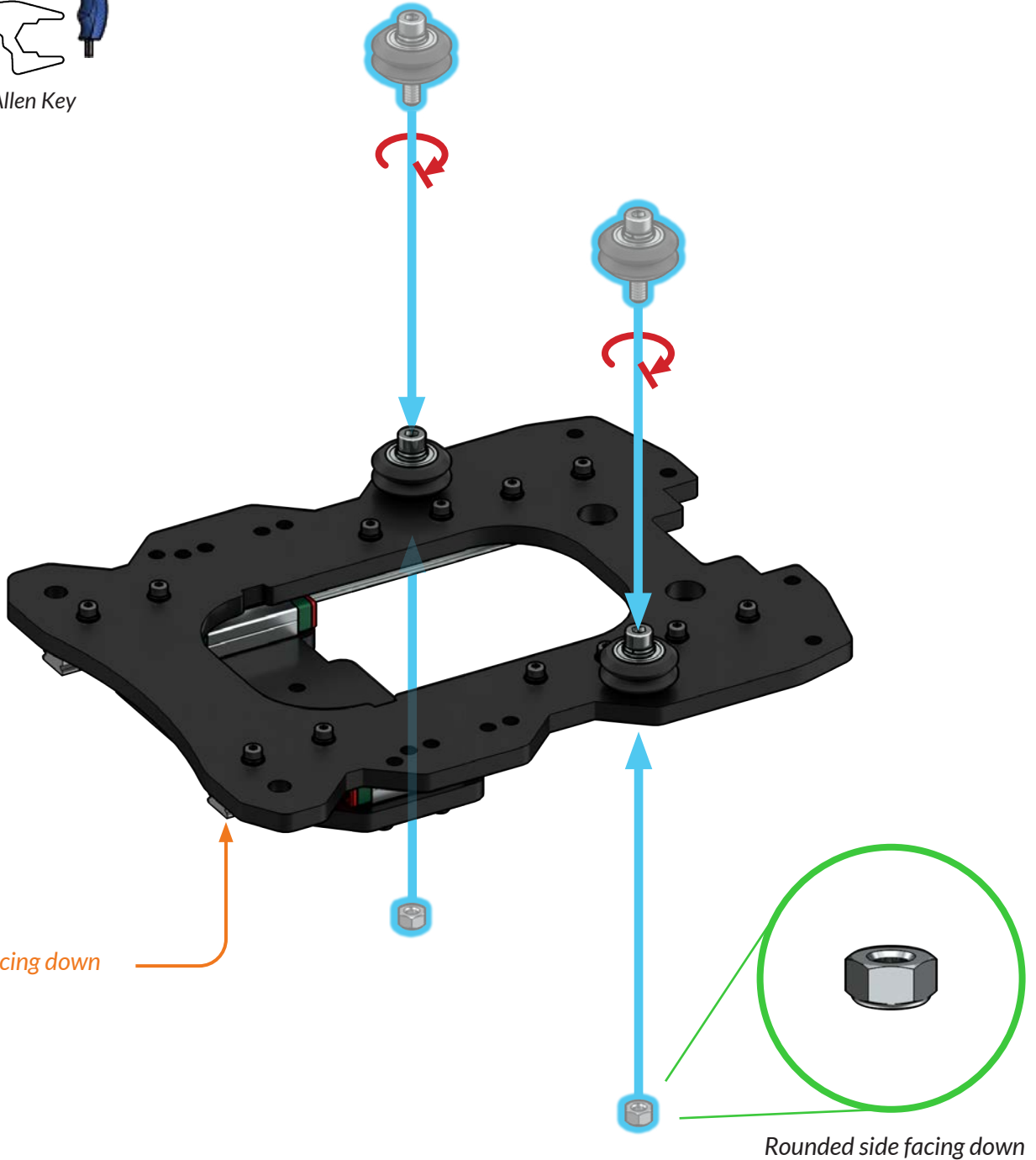

Rounded side facing down

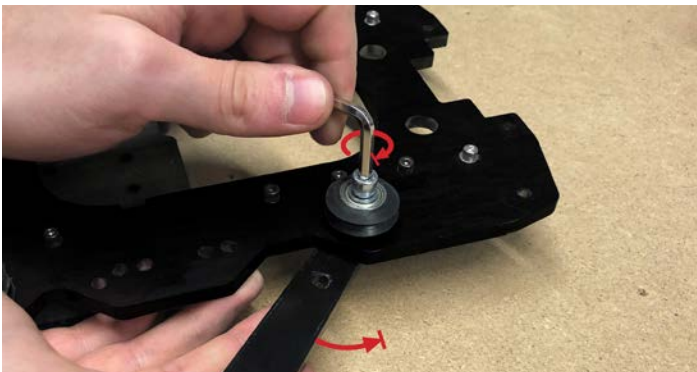

Install two of the v-wheel assemblies onto the XZ-gantry assembly with two nylock nuts. Use the included wrench to keep the nuts in place, while you use an M5 (size 4) Allen key to tighten the v-wheels. The rounded end of the nylock nuts should face away from the gantry. Ensure that the nylock nuts are firmly secured.

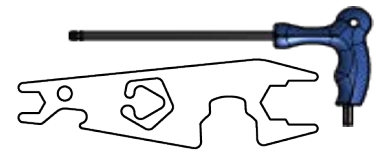

Use Wrench & M5 Allen Key

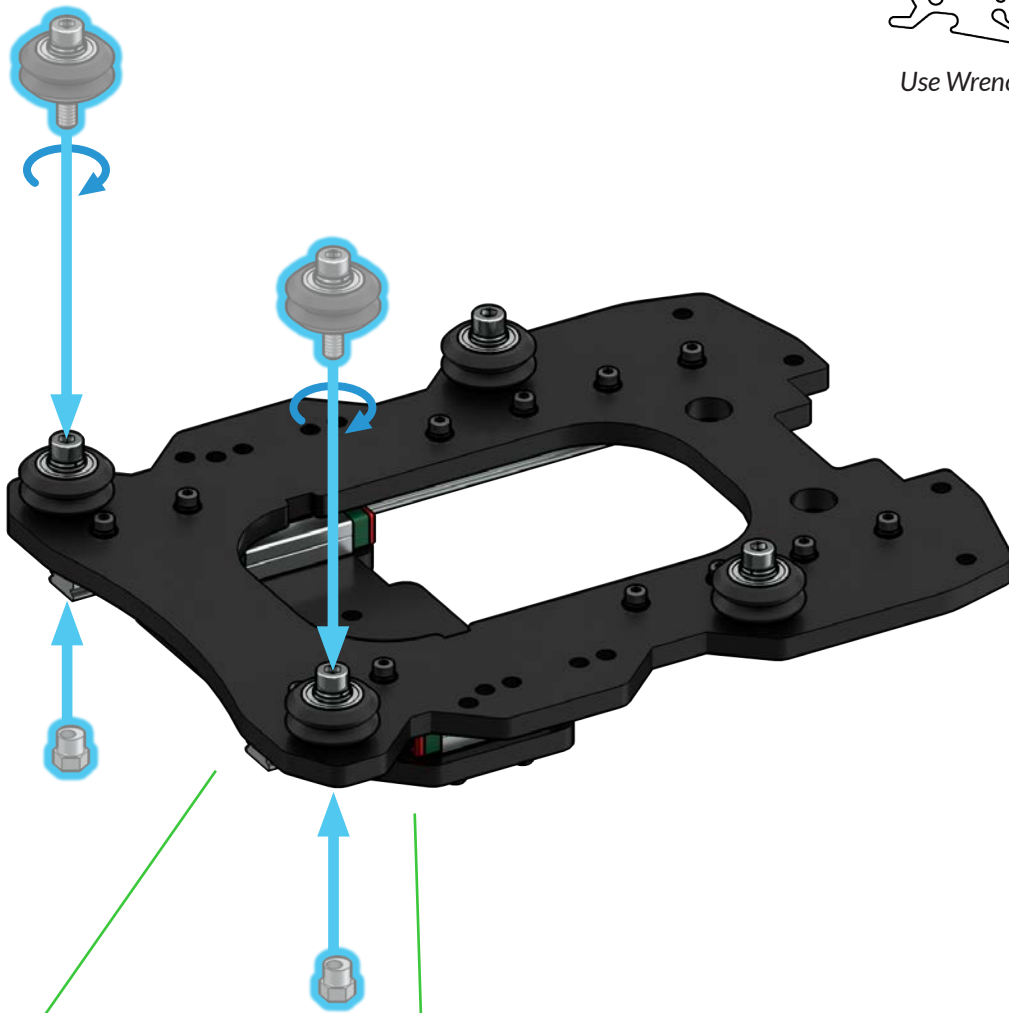

Install two v-wheel assemblies at the bottom edge of the gantry - except this time, use two eccentric nuts. When placing the eccentric nuts inside the gantry holes, ensure the inner holes of the nuts are oriented towards the bottom edge of the gantry (pictured). Use the included wrench to keep the nuts in place, while you use the Allen key to loosely attach the v-wheels.

Attaching Anti-backlash Nuts

Parts Needed:



x4

M5-25mm bolt

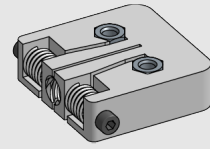

x2

Delrin anti-backlash nut assembly



Use M5 Allen Key

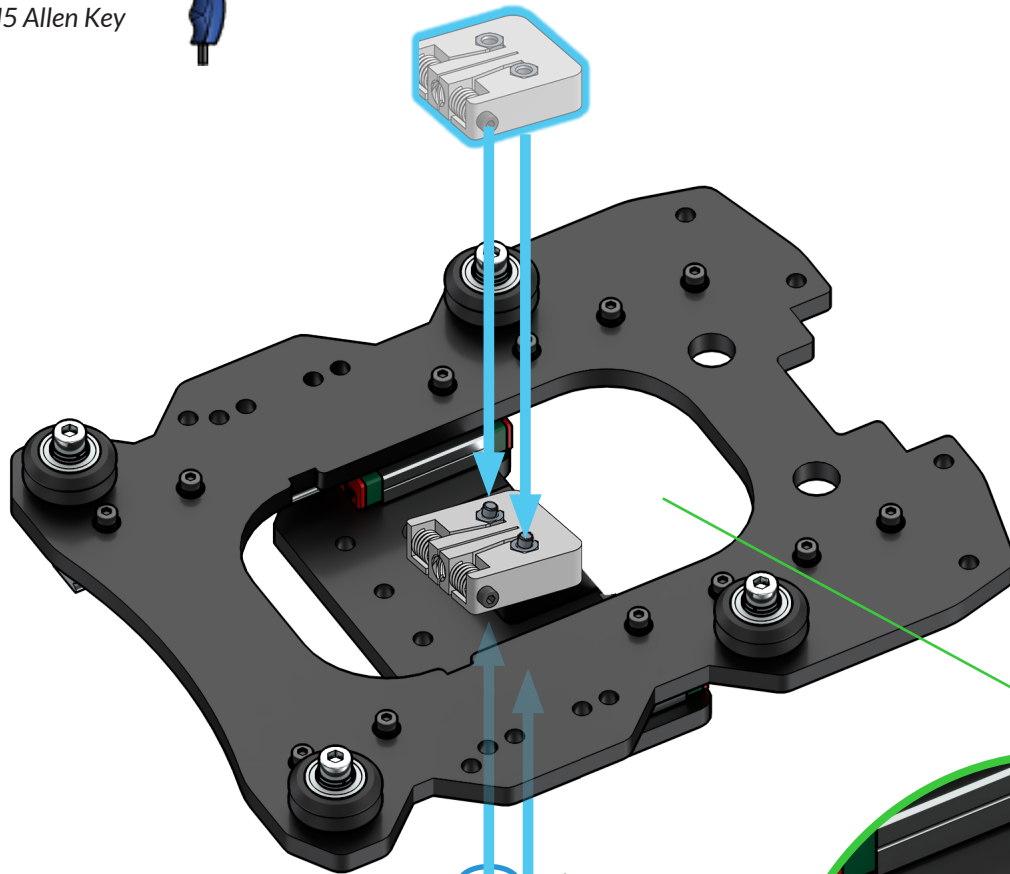

Remember that blue rotation arrows means a loose connection

Using two M5-25mm bolts, loosely attach one Delrin anti-backlash nut to the back of the sliding Z-gantry. Make sure to use the two holes near the notch on the gantry (pictured).



Use M5 Allen Key

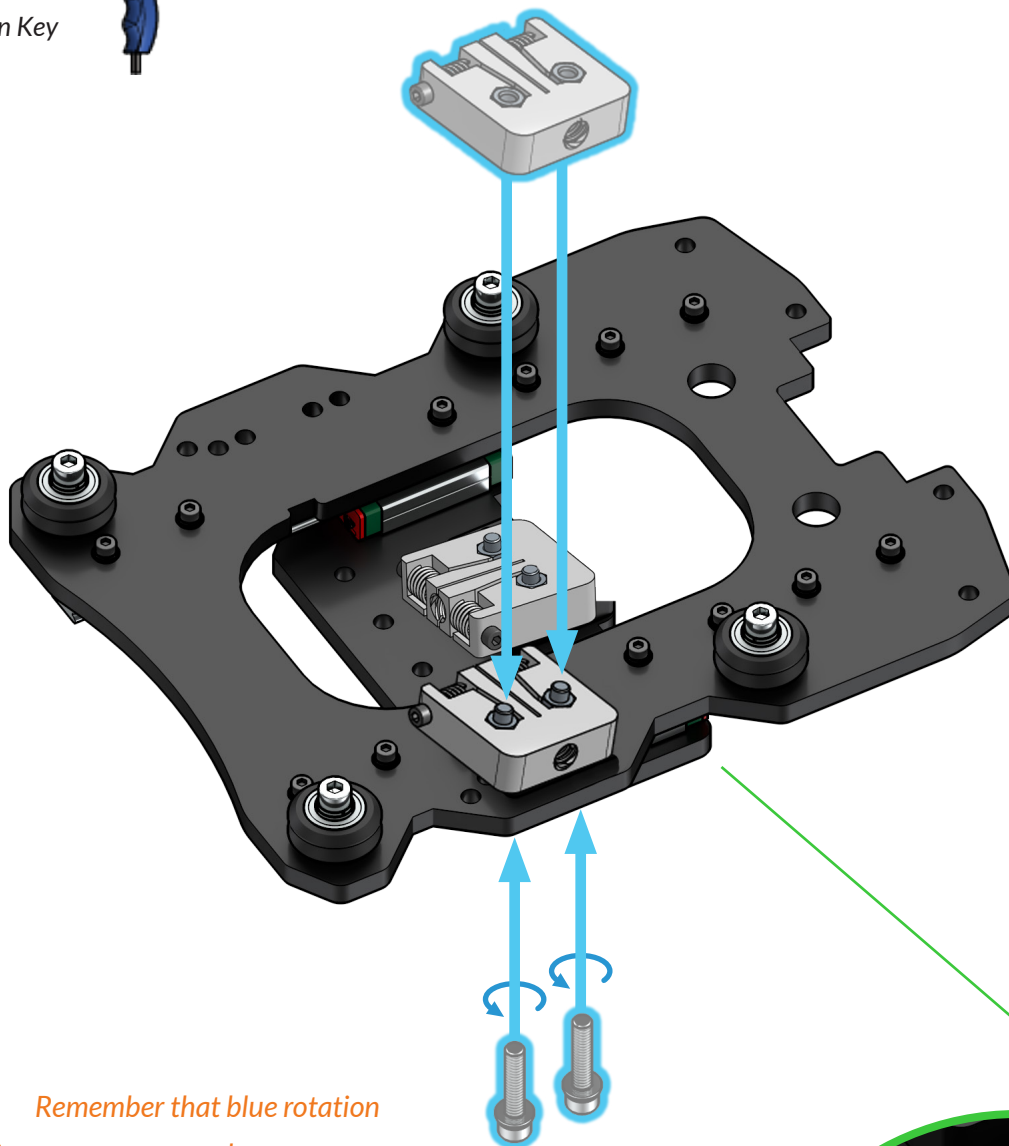

Remember that blue rotation arrows means a loose connection

Using another two bolts, loosely attach a second Delrin anti-backlash nut to the back of the X-gantry.

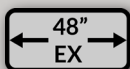

For the 48x30 size LongMill do not install this second Delrin anti-backlash nut. Go to **section C** "[EX Delrin nut mounting](#)" and return here once you've completed this step.

Connecting the Sub-assemblies

Parts Needed:



M5-25mm bolt

Previously Assembled

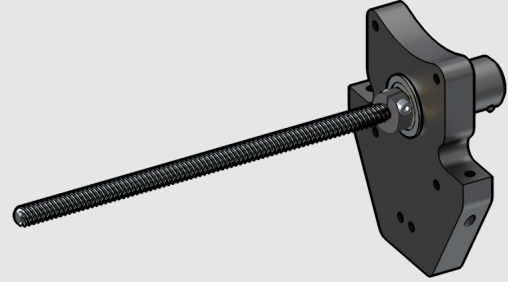

Z-axis motor mount

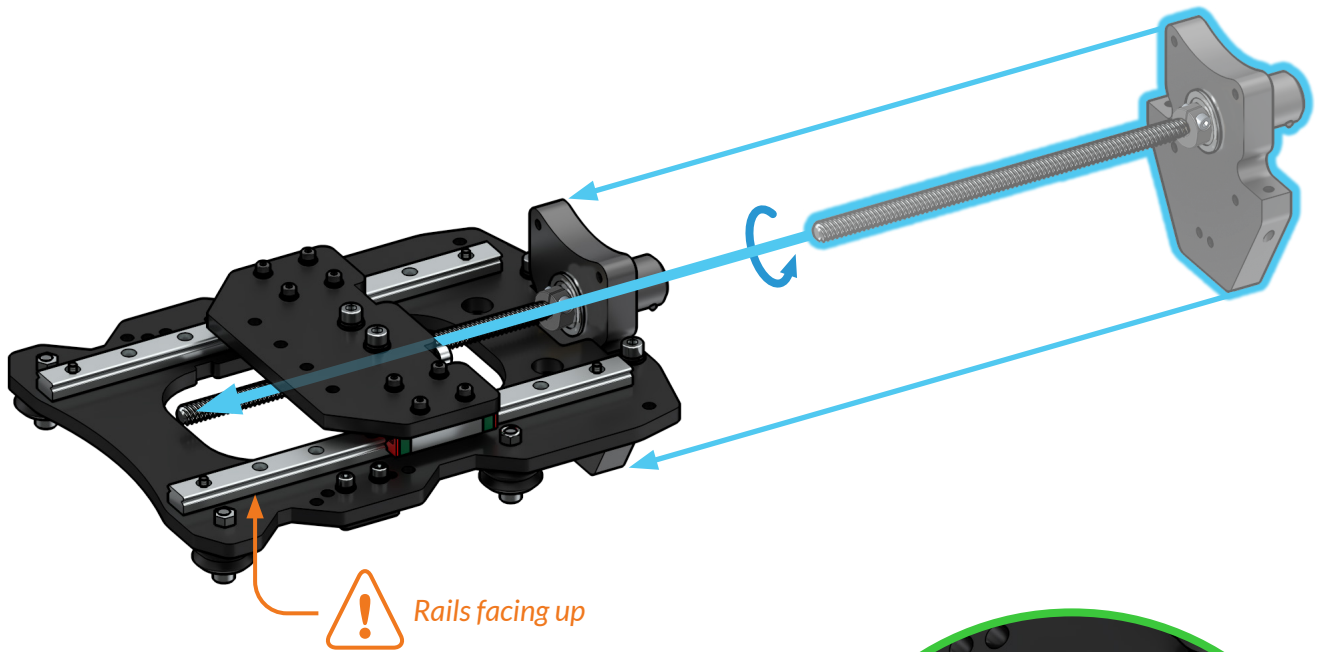

Slide the Z-axis motor mount onto the XZ gantry assembly, checking that the orientation is correct (pictured). Thread the lead screw into the Z-gantry anti-backlash block between the two steel plates.

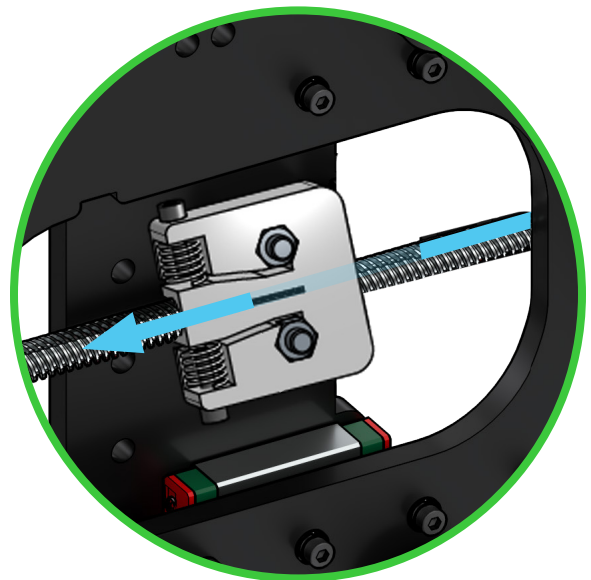

Anti-backlash block view from bottom



Use M5 Allen Key

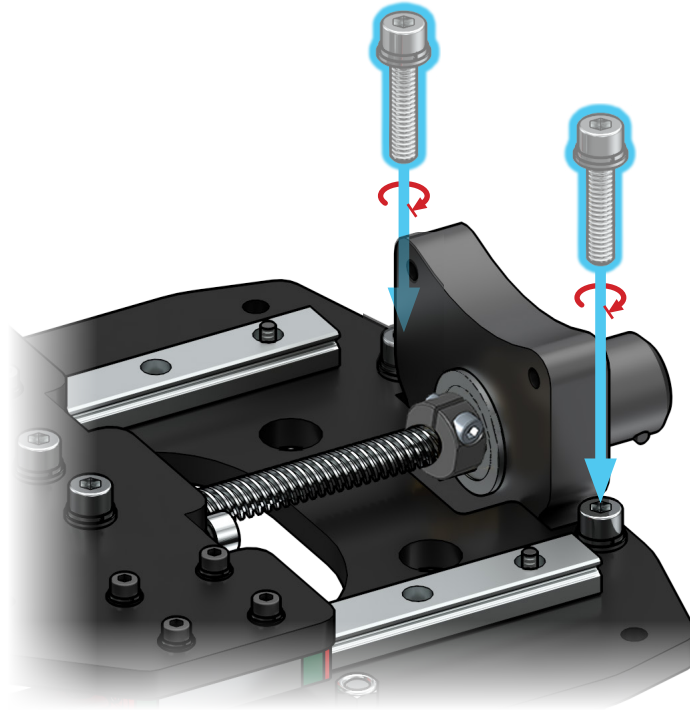

Fasten two M5-25mm bolts on both sides of the Z-axis motor mount to secure the two assemblies together.

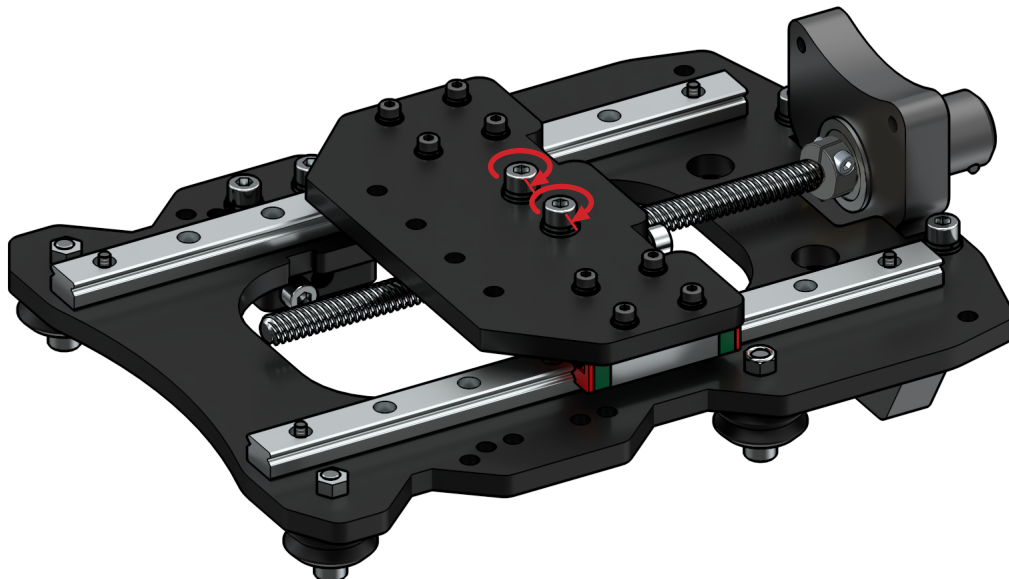

With everything secured together, you can finish tightening the two bolts holding the Z anti-backlash nut. Alternate making a couple turns onto one bolt and then the other until they're both tightened down. If you twist hard onto just one bolt while the other one is loose it can twist the anti-backlash nut and misalign it to the lead screw.

Attaching the Router Mount

Parts Needed:



M5-25mm bolt

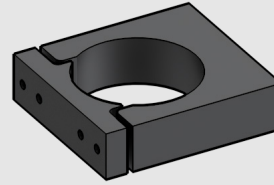

Aluminum router mount

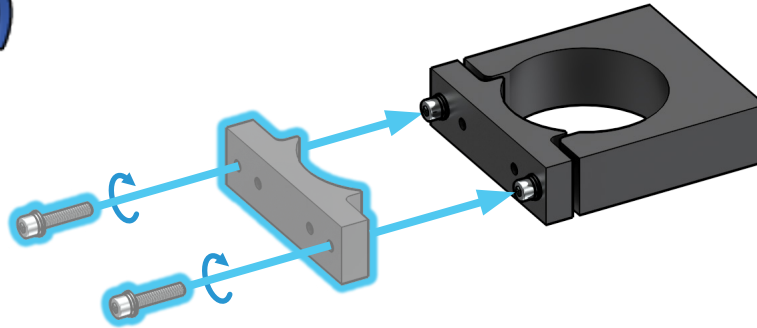

Grabbing the router mount from the 'variable box', loosely attach the front using two M5-25mm bolts, then bolt the mount to the XZ gantry assembly with another four M5-25mm bolts. Ensure the bottom of the router mount is flush with the bottom of the Z-gantry.

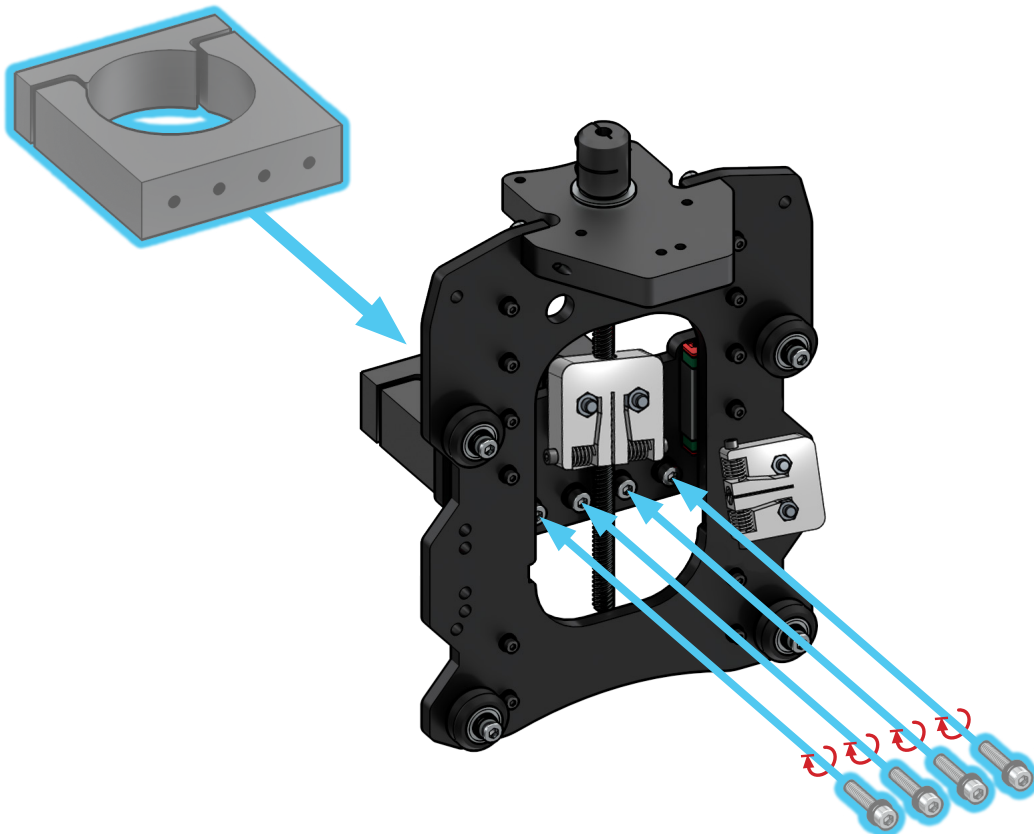

Part 2 Y-Axis Gantries

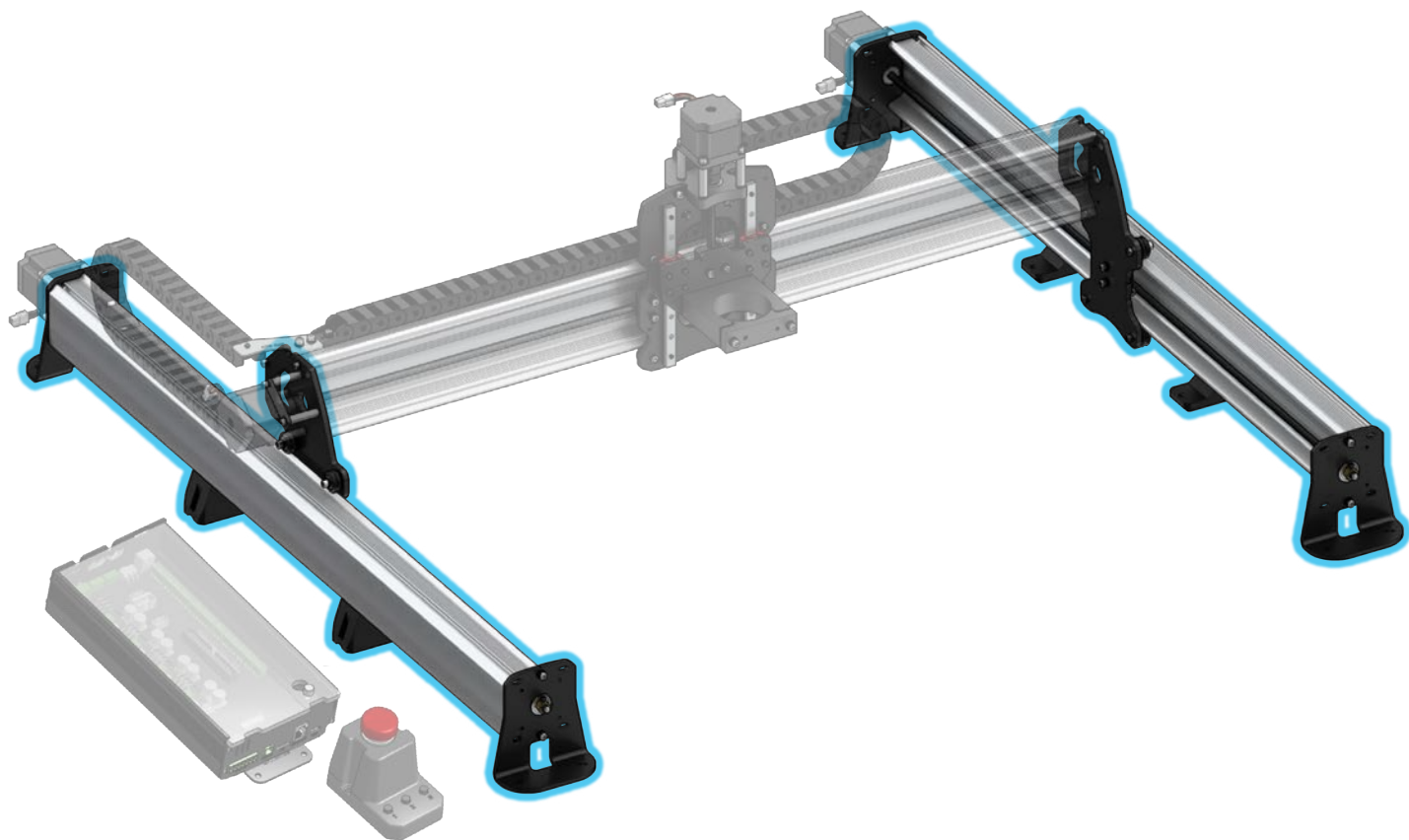

Y-Gantry Wheels

Parts Needed:



x2

Y-axis gantry

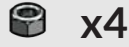

x4

M5-nylock nut



x4

Eccentric nut

Previously Assembled



x8

V-wheel assembly

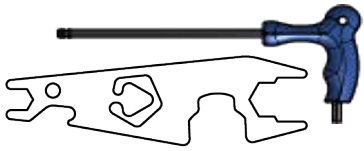

Use Wrench & M5 Allen Key

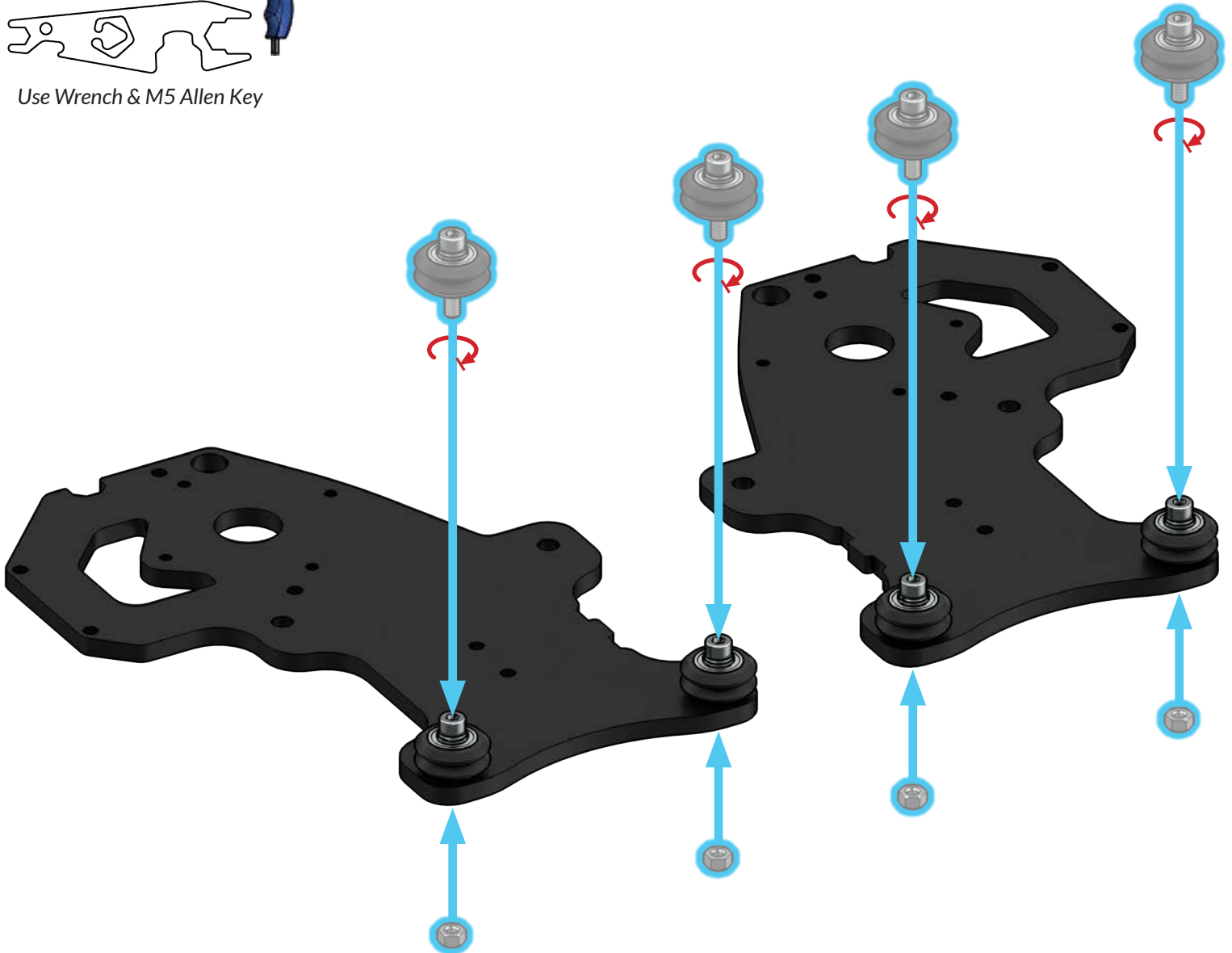

Install two v-wheel assemblies to each Y-axis gantry using nylock nuts. Similar to previous steps, use the M5 Allen key and included wrench to firmly secure the nylock nuts.

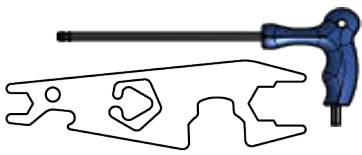

Use Wrench & M5 Allen Key

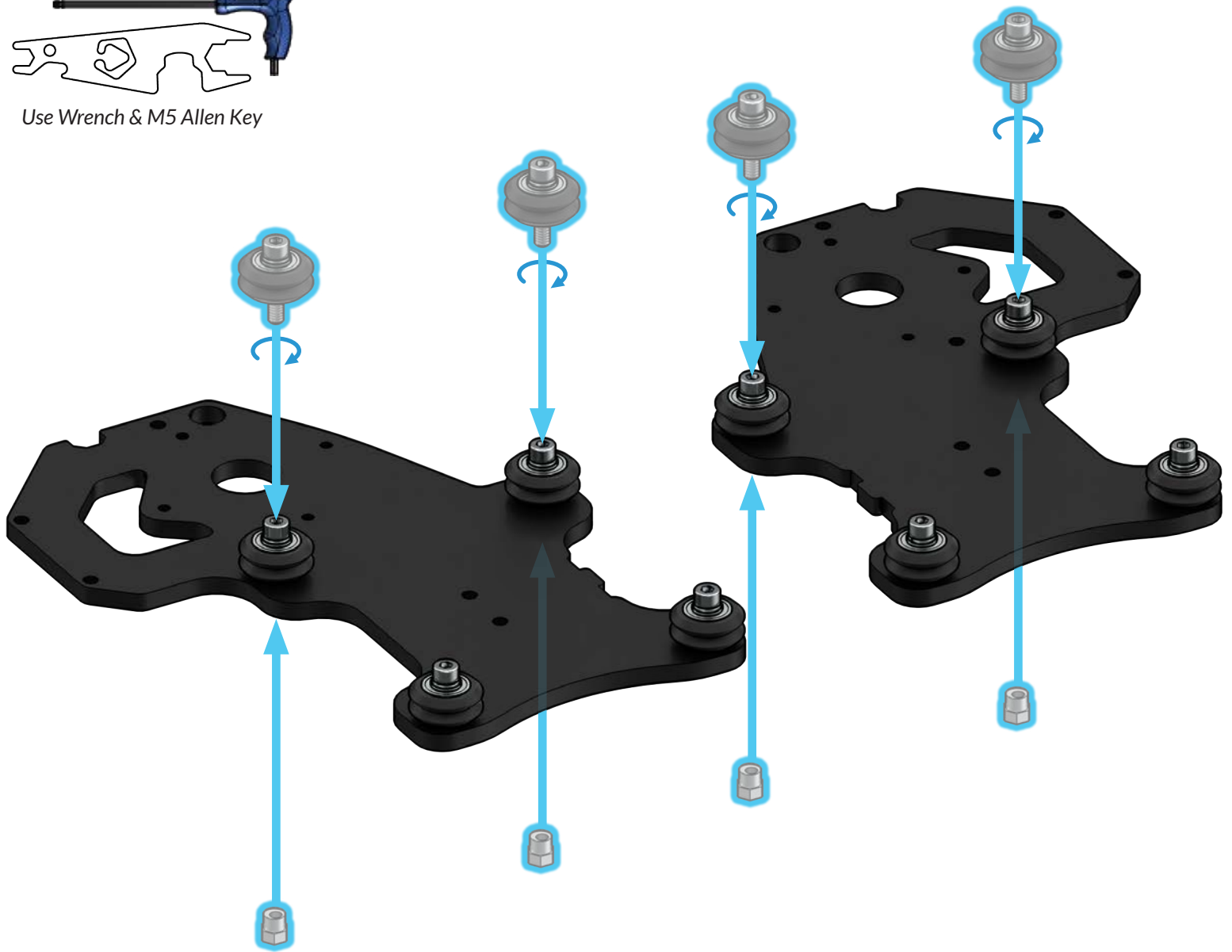

Now, loosely install two v-wheel assemblies in the upper set of holes on each Y-axis gantry, using eccentric nuts. Orient the inner holes of the eccentric nuts away from the bottom edge of the gantry (pictured).

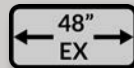
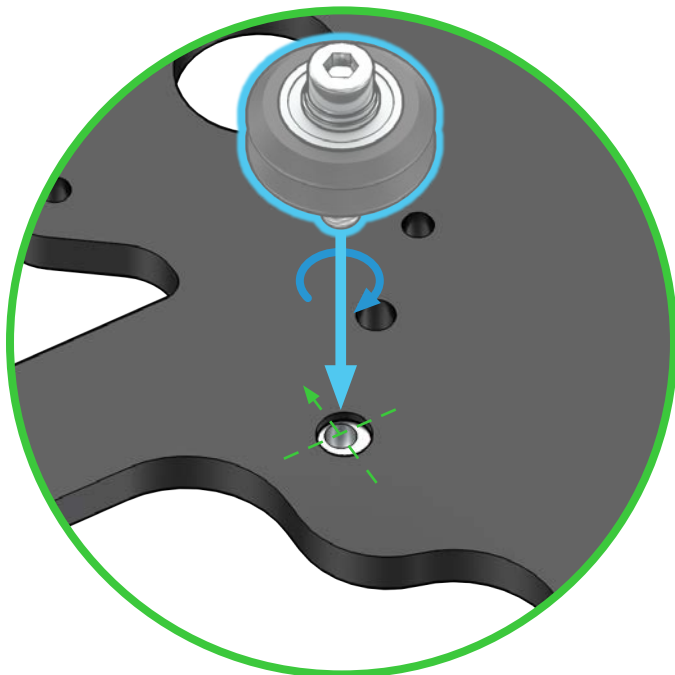

If you're assembling the 48x30 size LongMill go to section D "[EX Y-gantry assembly](#)" and then return here once you've completed that step.

Y-axis Anti-backlash Nuts

Parts Needed:

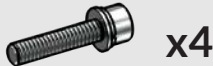

M5-25mm bolt

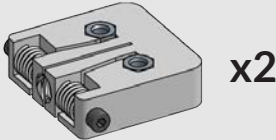

Delrin anti- backlash nut

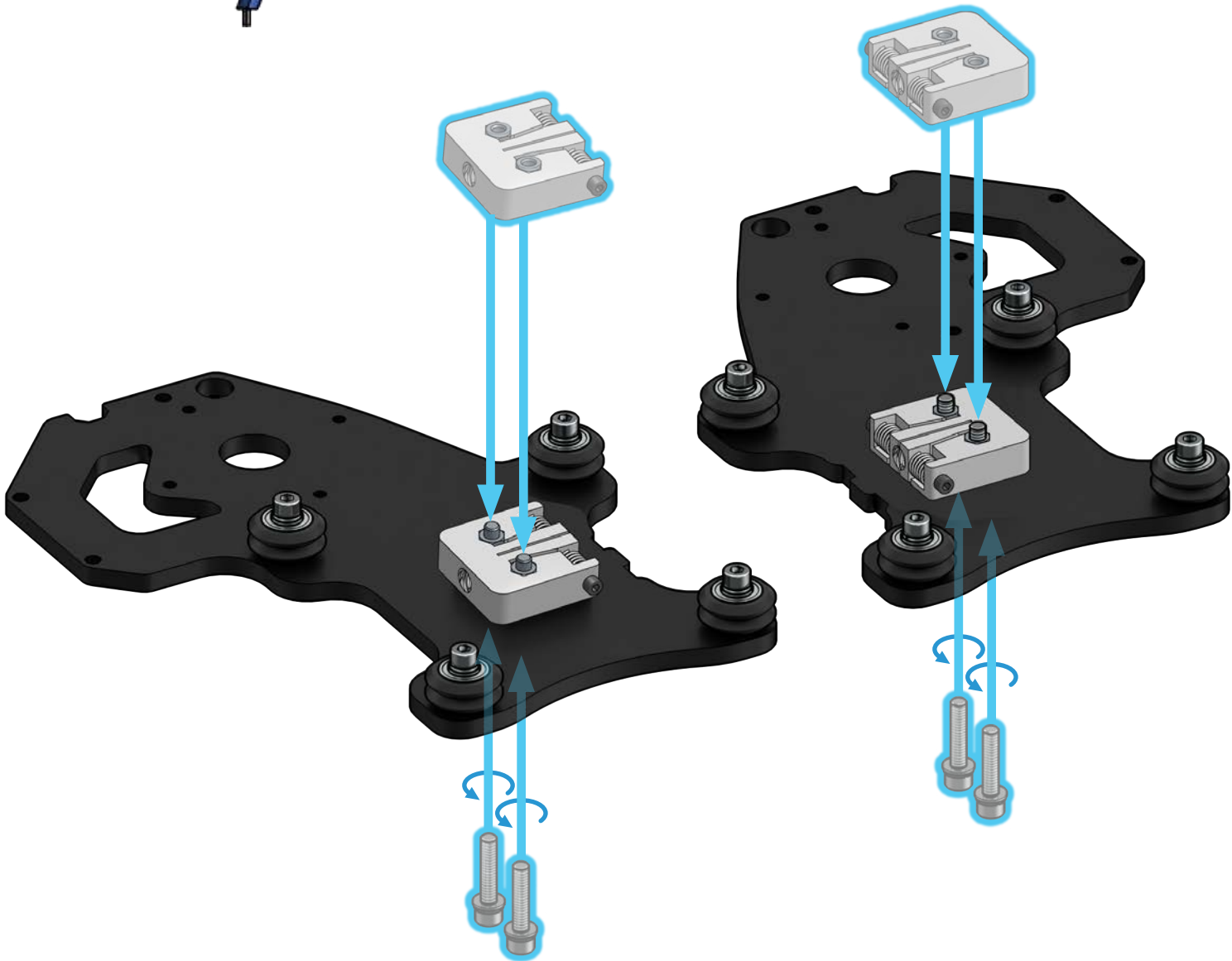

Using two M5-25mm bolts, loosely attach the two Delrin anti-backlash nuts to the back of each Y-gantry.

Y-axis Middle Feet

Parts Needed:



M5-25mm bolt



T-nut

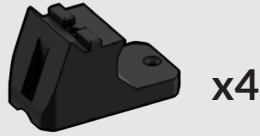

Middle foot



Y-axis rails



Use M5 Allen Key

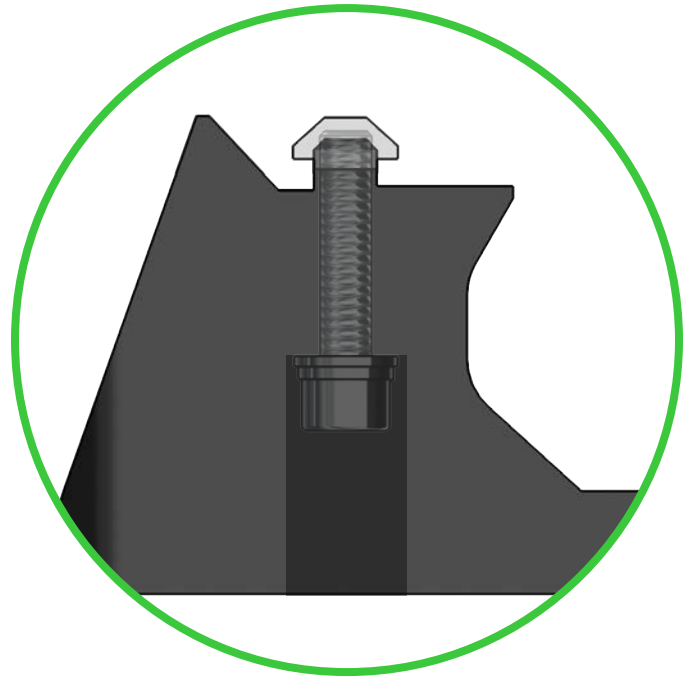
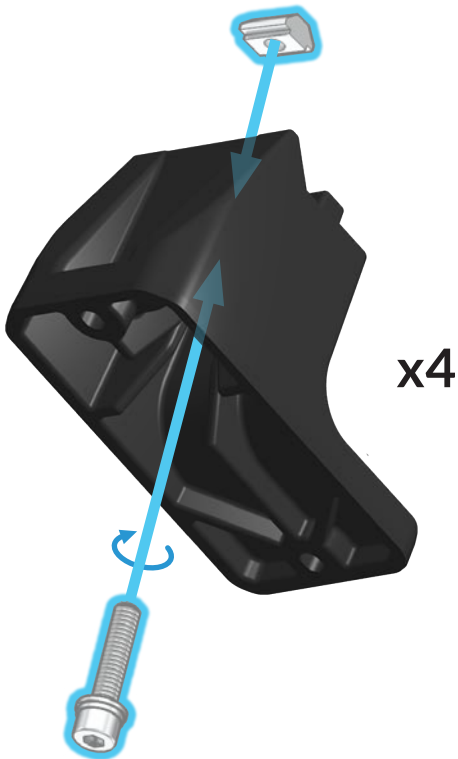

At this point of the assembly process we will begin using hardware from the yellow bag in addition to the green bag. The middle feet will be alongside the hardware bags and note that 12x30 LongMills will have shorter Y-axis rails than pictured.

From the yellow sticker bag, grab four t-nuts. For all four middle feet, insert M5-25mm bolts through from the underside and turn them about 2 turns with an M5 Allen key into the t-nut from above. Don't tighten them all the way, as we want these bolts slightly loose so we can slide them onto the rail in the next step.



Use M5 Allen Key

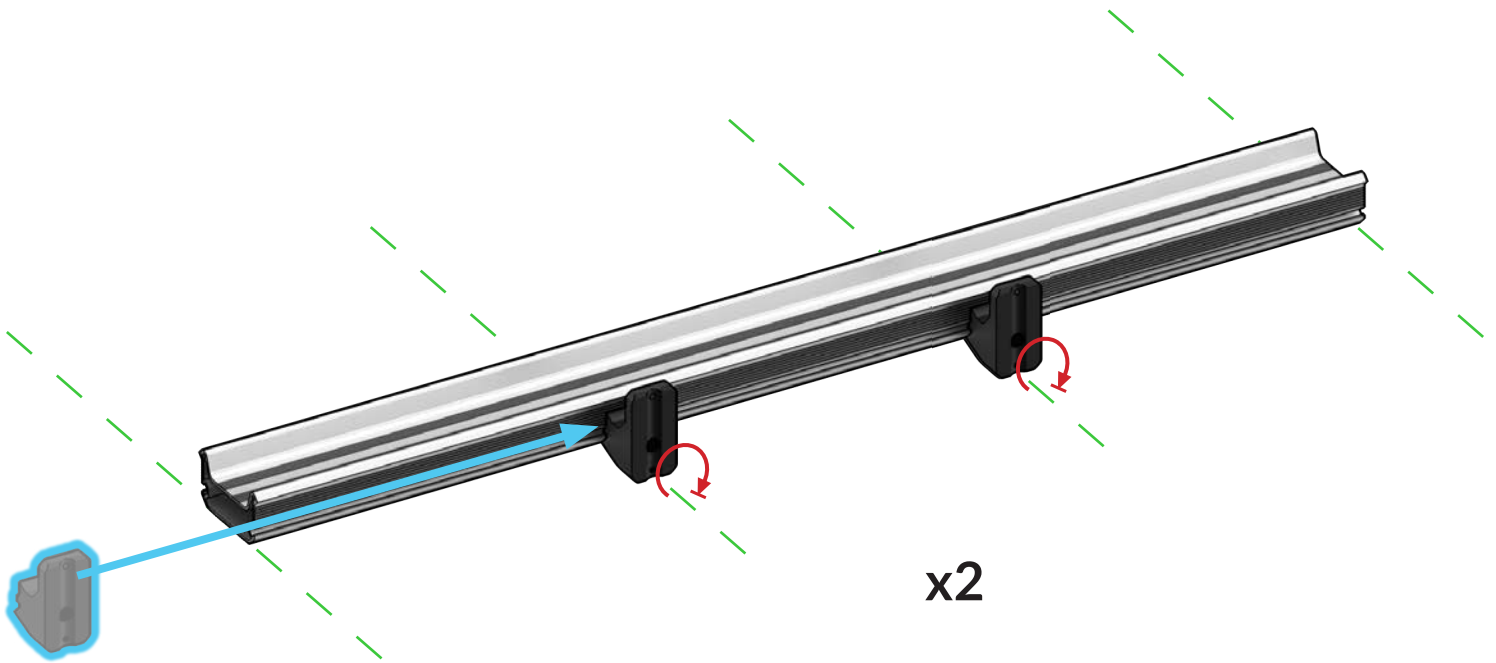

Slide in two feet assemblies through the slots of each Y-axis. Position them about 1/3 from each end then tighten the M5 bolts at the bottom of each foot to secure them into place.

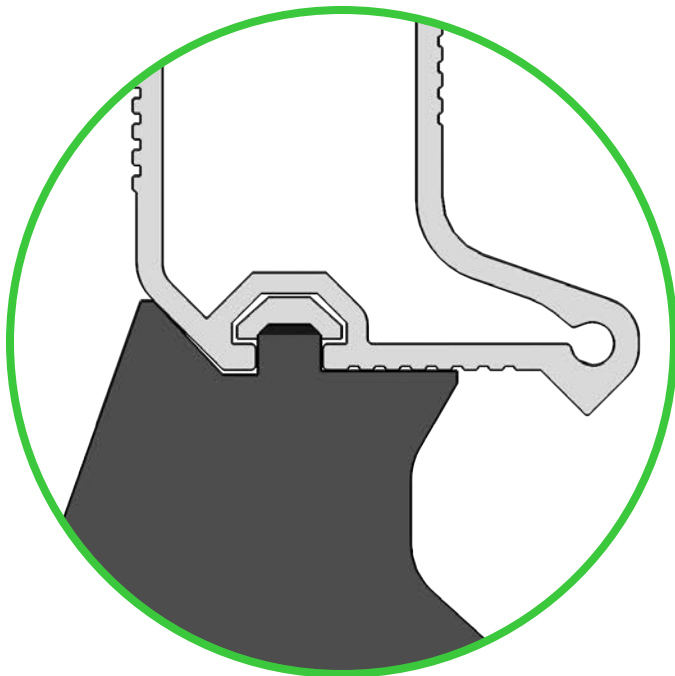

Sliding the foot onto the rail

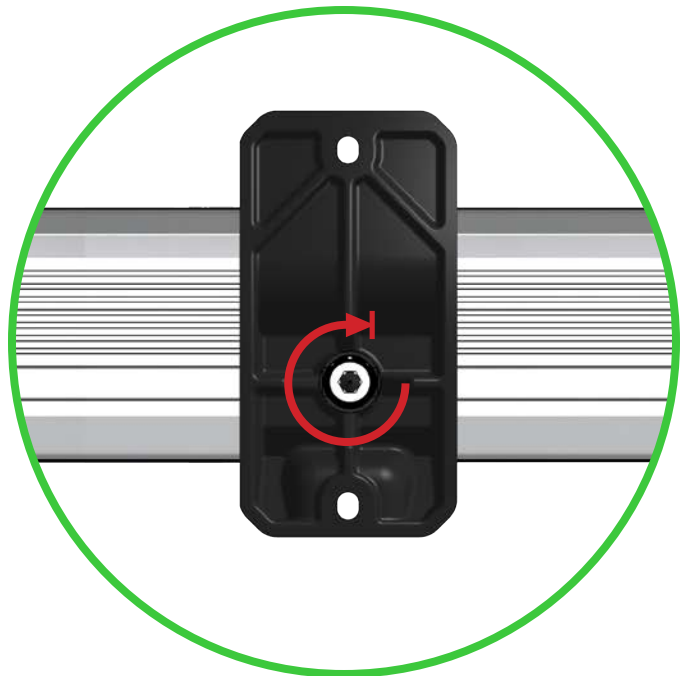

Tightening the bolts on underside of each foot

INTERMISSION

From this point onwards until the completion of the Y-axis rail assemblies, we will only show the steps for the **right** Y-axis rail. While you are assembling the right Y-axis rail, complete the steps again for the left Y-axis rail.

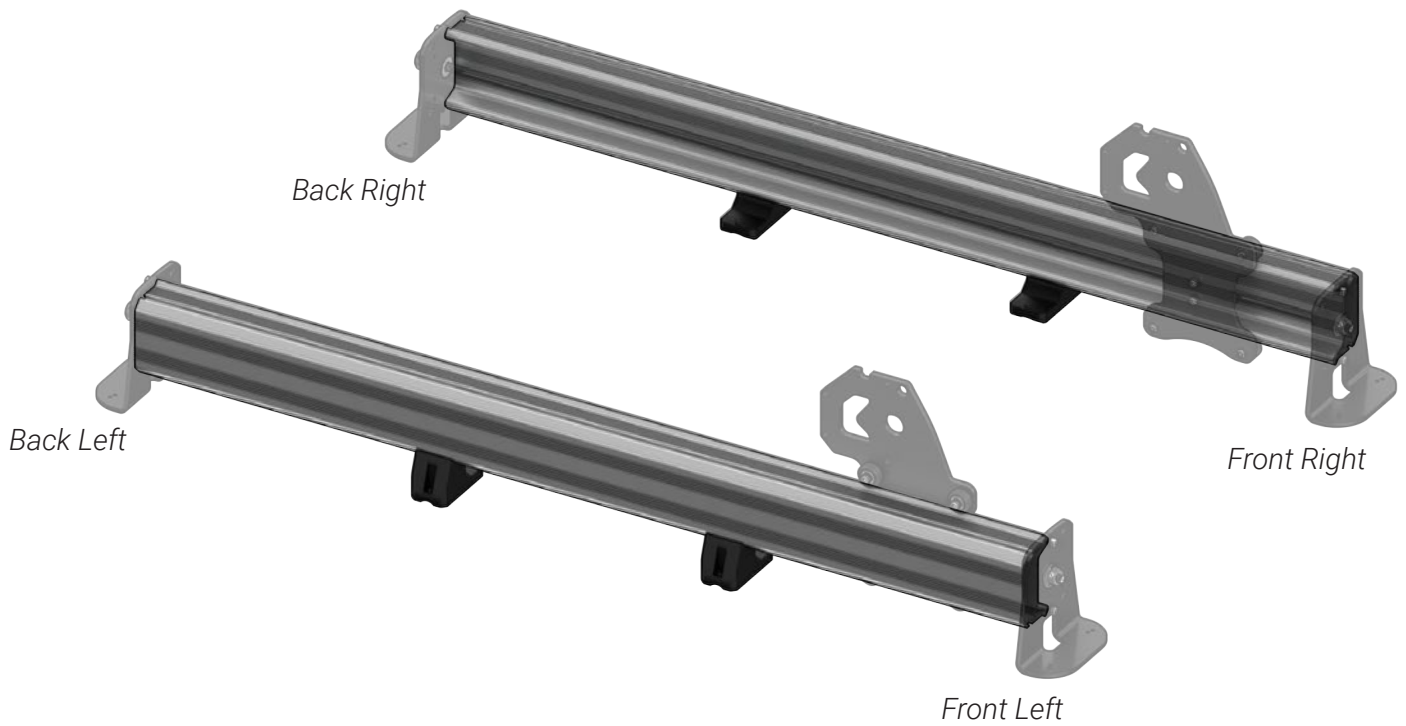

The following icon will be shown on each page where you should be repeating the steps for the second rail, but mirrored.



Y-axis End Feet

Parts Needed:

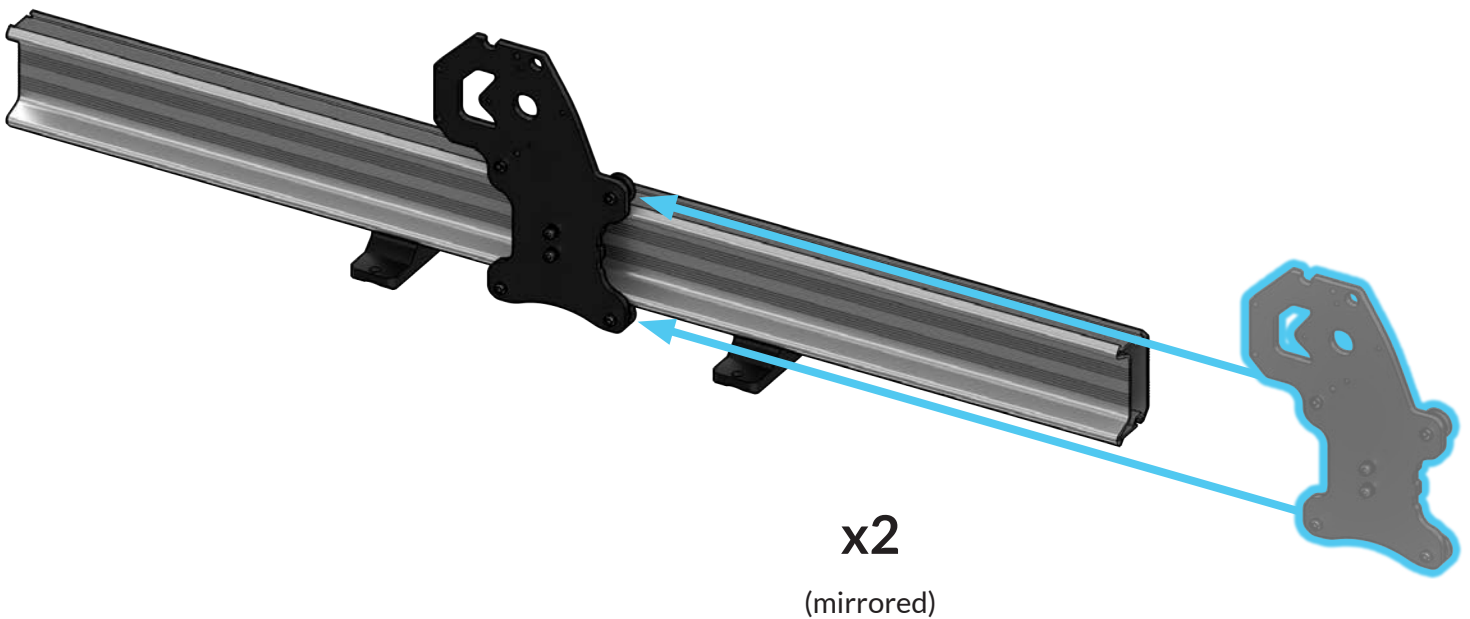
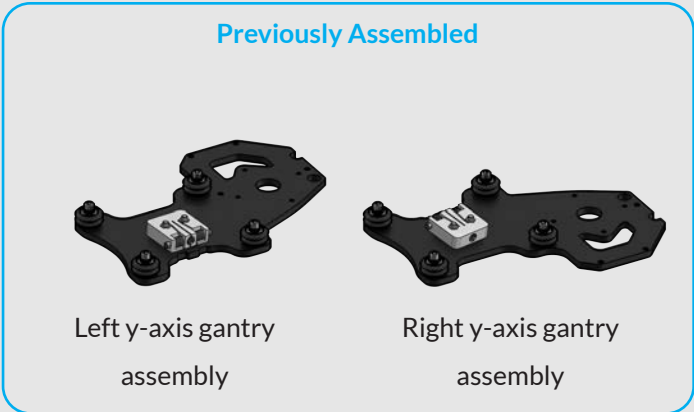

Slide the Y-gantry plate onto the Y-rail. The v-wheels should sit on the pointed edges on each side of the Y-rail (pictured).

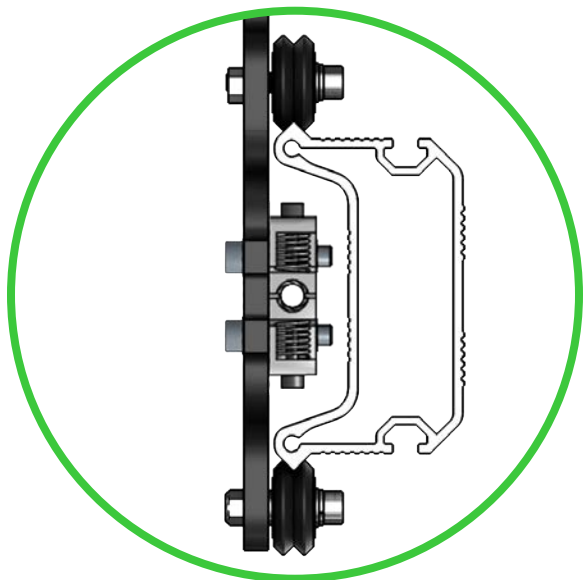

Delrin wheels rolling onto the Y-rail



Use M5 Allen Key

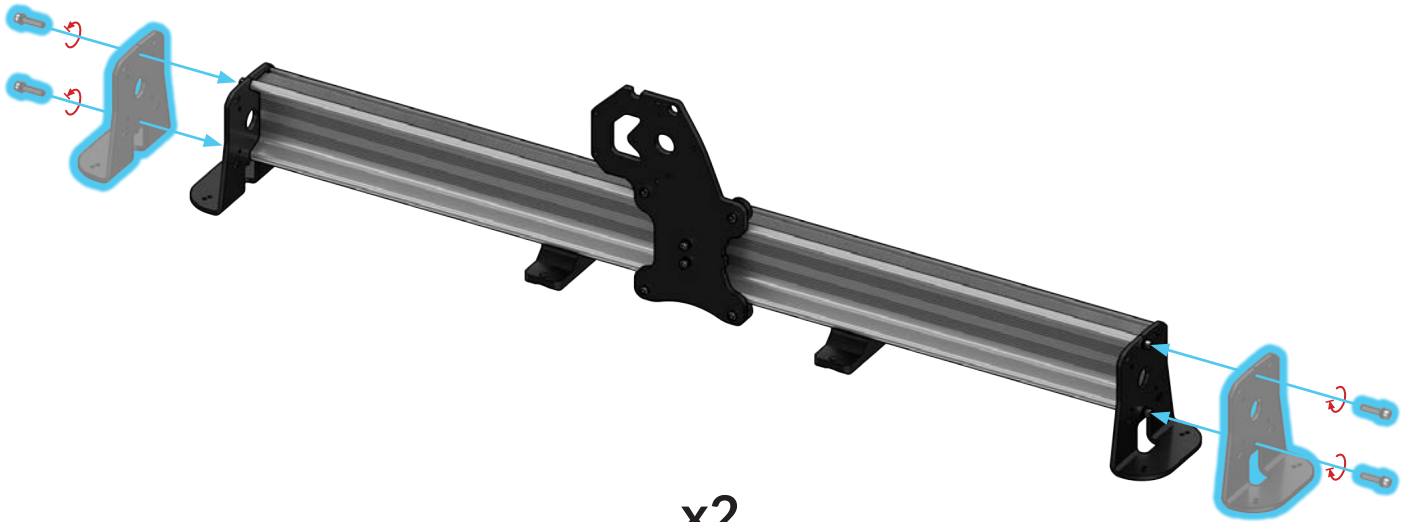

x2

(mirrored)

Finding all 4 steel end feet in a cardboard wrap, attach two end feet onto each end of the Y-axis rail using two M5-25mm bolts for each foot. Remember to be mirroring these steps for the other Y-axis rail.

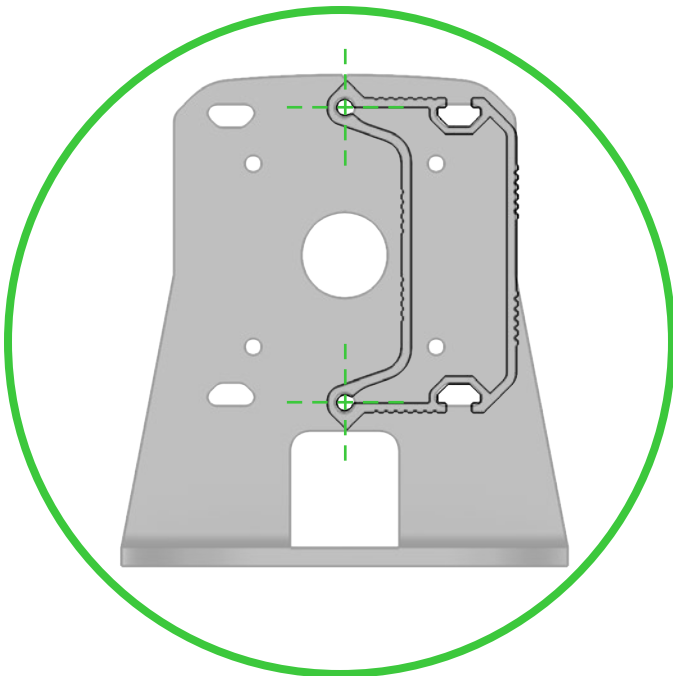

Foot aligning to the rail

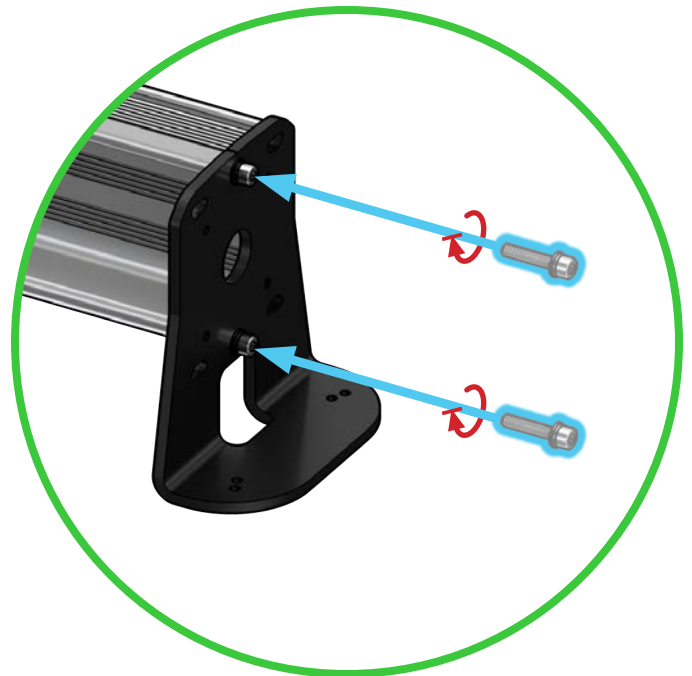

Bolting feet into place

Y-axis Lead Screws

Parts Needed:

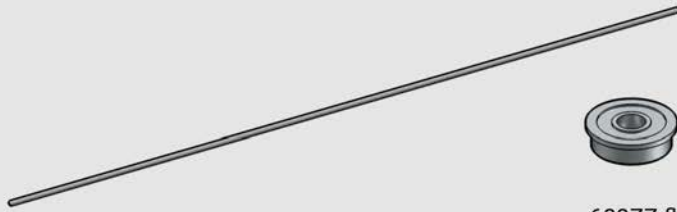

1000mm lead screw

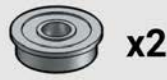

x2

608ZZ flange bearing



6.35mm to 8mm coupler



T8 clamping ACME nut

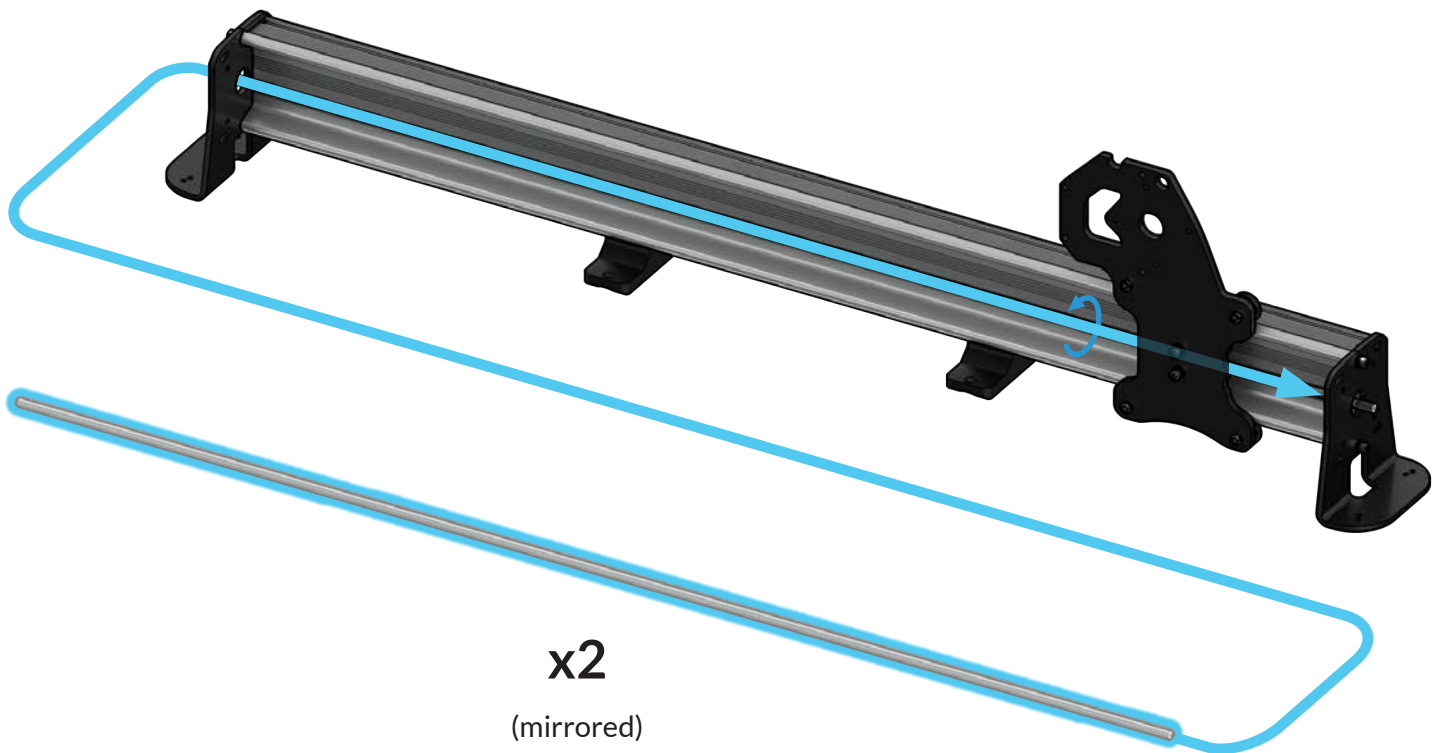

Thread a lead screw through the anti-backlash block behind the Y-gantry (for the 12x30 this will match the length of the rail). The ends of the lead screw should be able to rest in the big holes on both steel end feet.

If you find that it's difficult to thread on, ensure you're bringing in the lead screw from the right direction (pictured). If you remember, the anti-backlash nuts have a little arm on them and you can also try reaching between the steel Y-gantry and the rail to reach the nut and wiggle this arm to assist in threading the lead screw on. Worst case, remove an end foot and roll the Y-gantry back off to check the anti-backlash nut for burrs and debris and try threading on the lead screw again. You can also try swapping to the spare block if needed.

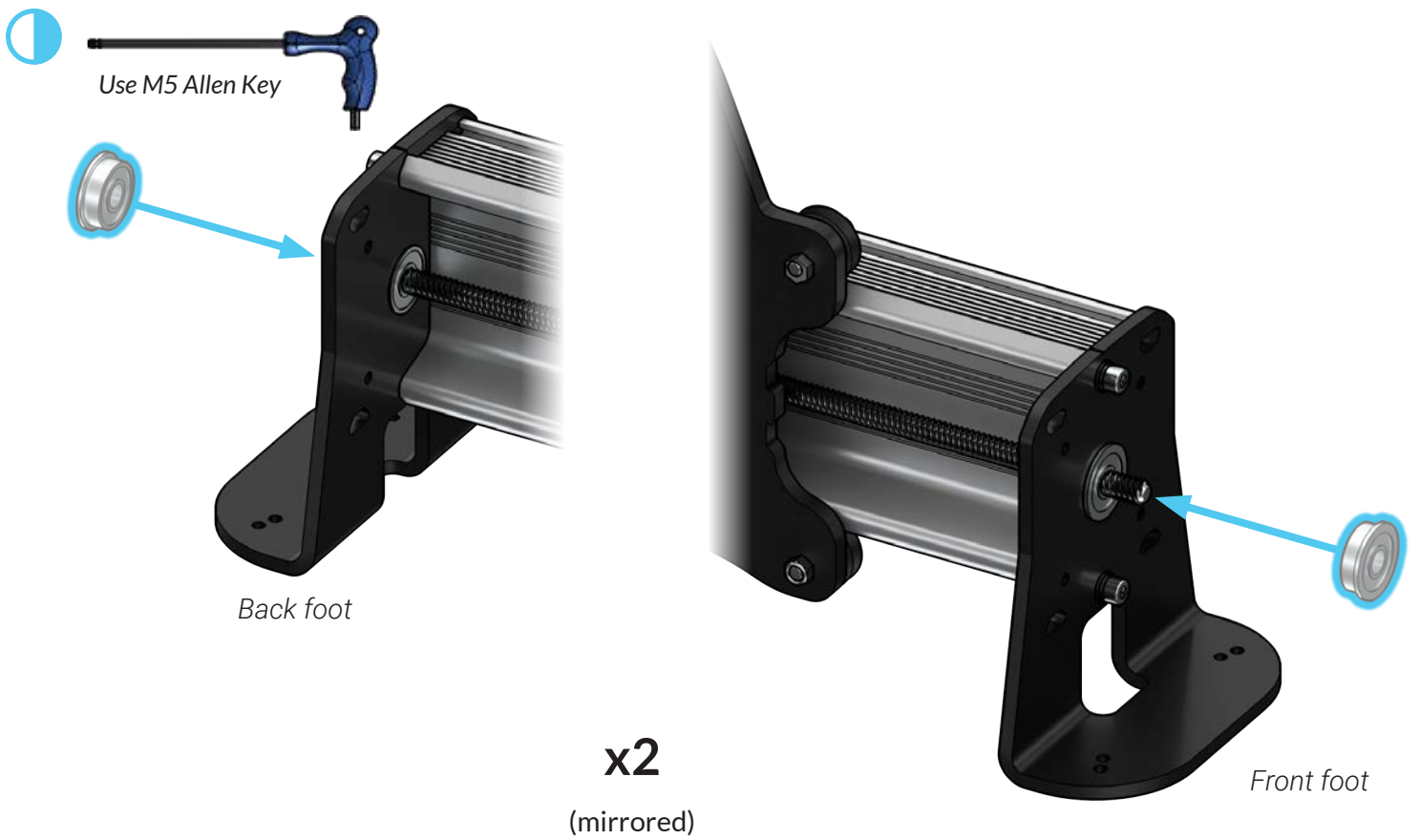

Insert one flange bearing onto each end foot from the outside, making sure the lead screw goes through the bearings. This fit may be tight so just do your best to hold everything in place and try to wiggle the lead screw or tap it with a mallet if needed.

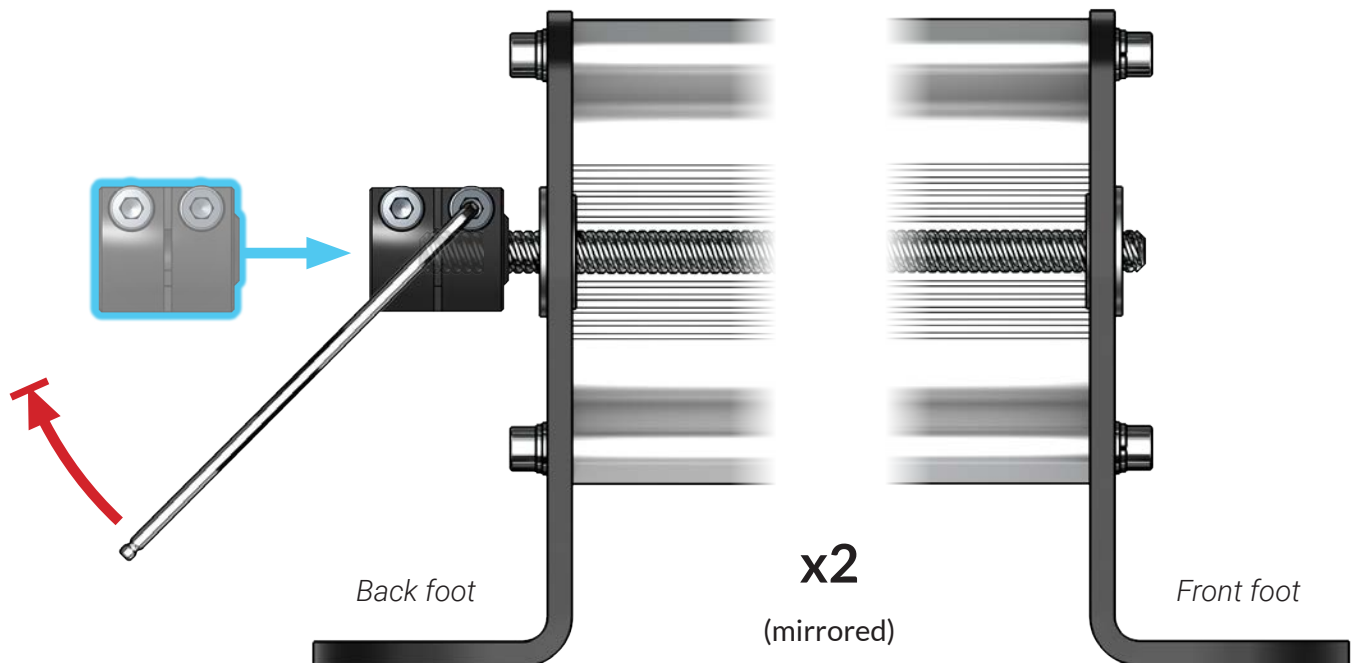

Identifying the back end foot, slide the coupler on until it bottoms out on the lead screw. Firmly secure the coupler at the set screw using an M5 Allen key. Remember to only tighten ONE of the set screws - the one on the lead screw side (as pictured).



Use M5 Allen Key

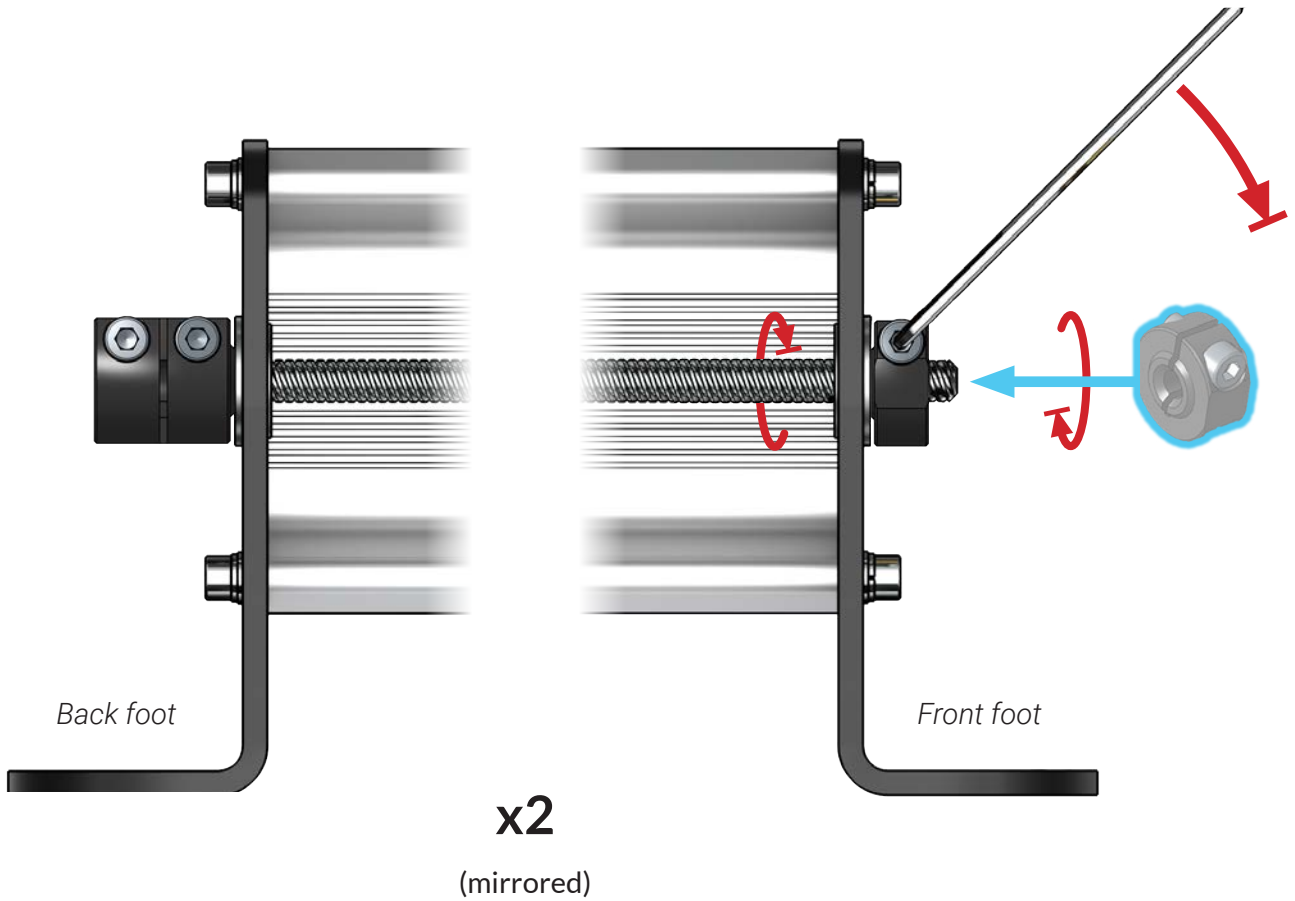

At the front, use both hands to thread a locking ACME nut into the lead screw so that it pulls it flush to the flange bearing and brings the coupler flush against the back foot flange bearing. While holding this tension in place, firmly tighten the set screw on the ACME nut. This makes another 'bolted sandwich' where everything should be touching bearings (as pictured) and the lead screw should only be allowed to rotate, and not move in-and-out.

Remember, the small shoulder for the T8 clamping nut will face in to the flange washer.

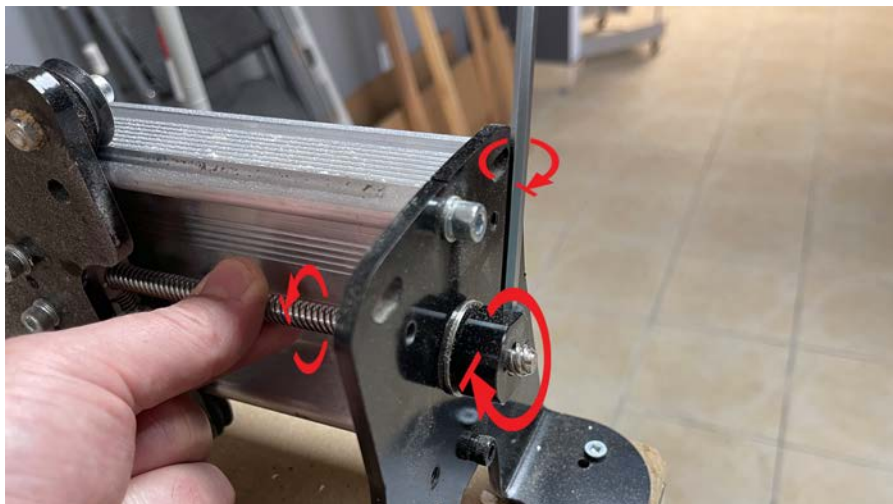



You should now have two Y-axis rail assemblies! They should be a mirror copy of each other.

Part 3

Axes Completion

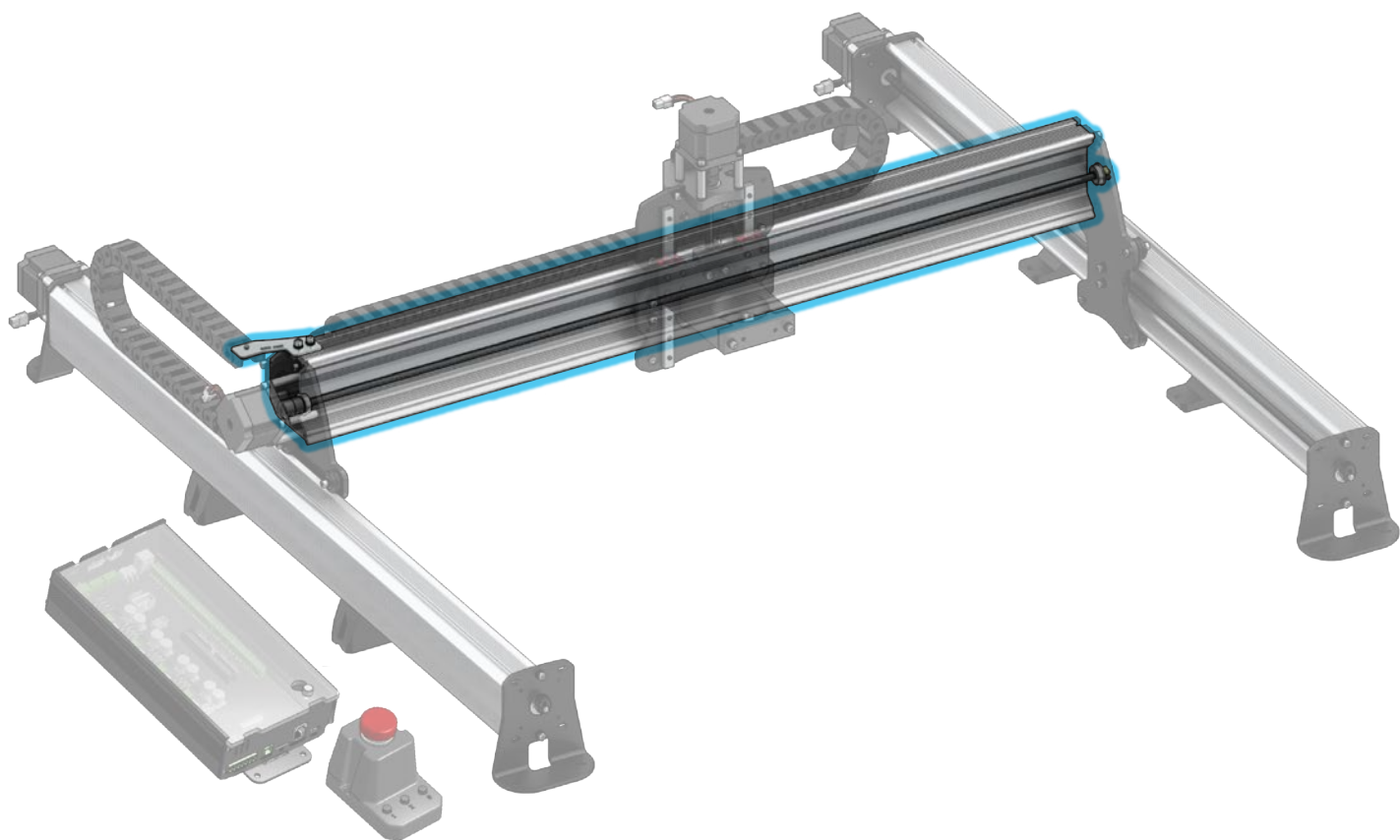

Drag Chain Mount and Connecting Rails

Parts Needed:

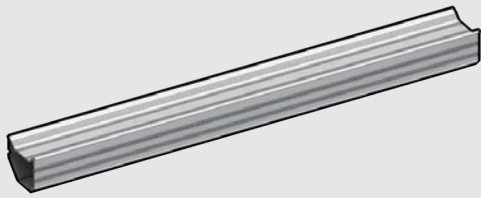

X-rail

Previously Assembled



Right Y-rail assembly



Drag chain mount



x4

M5-25mm bolt



x2

M5-10mm bolt



x2

T-nut



If you want your control box on the right side, then all the next steps should be flipped

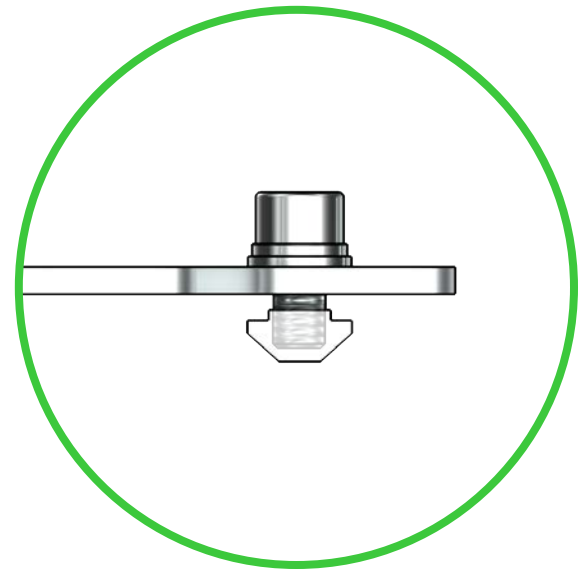
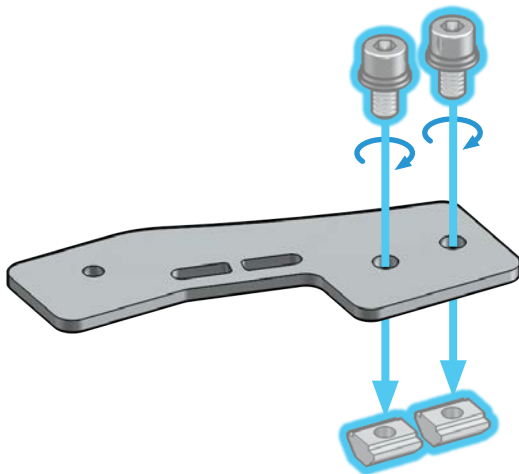

Leave a gap between the T-nut and mount

Grab the M5-10mm bolts, t-nuts, and steel drag chain mount from the yellow hardware bag. Prepare the drag chain mount by loosely threading two M5-10mm bolts into the two t-nuts.

Note: if you want your control box on the right side rather than the left then most of the remaining steps should be flipped including drag chain mount, subassembly steps, X-axis lead screw and motor, and drag chains.

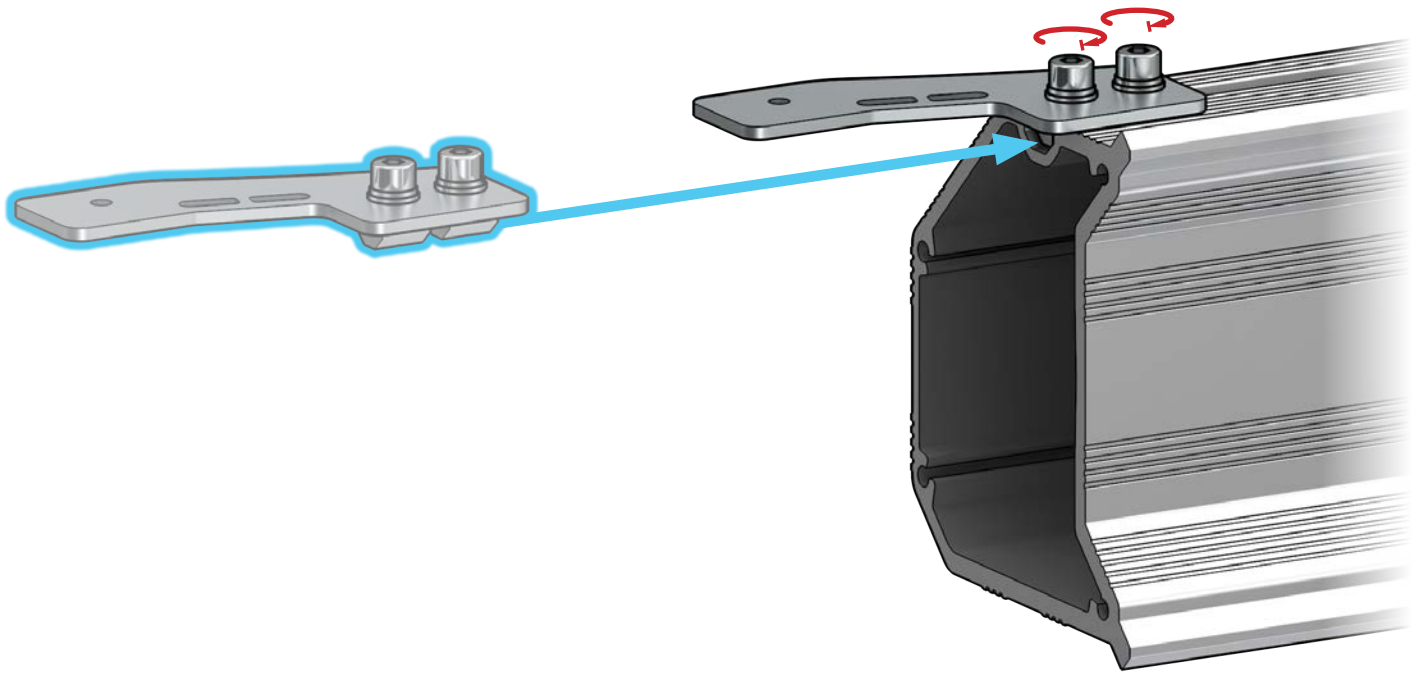

Attach the drag chain mount through the left side of the X-axis rail by sliding two t-nuts onto the top slot of the rail. Before fastening the drag chain mount, ensure that it is offset from the edge of the rail by about 6mm or 1/4" (pictured).

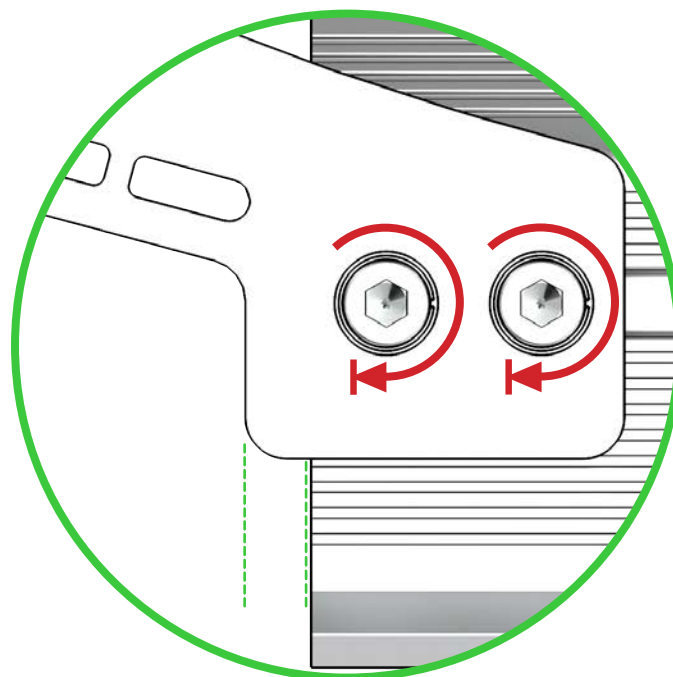

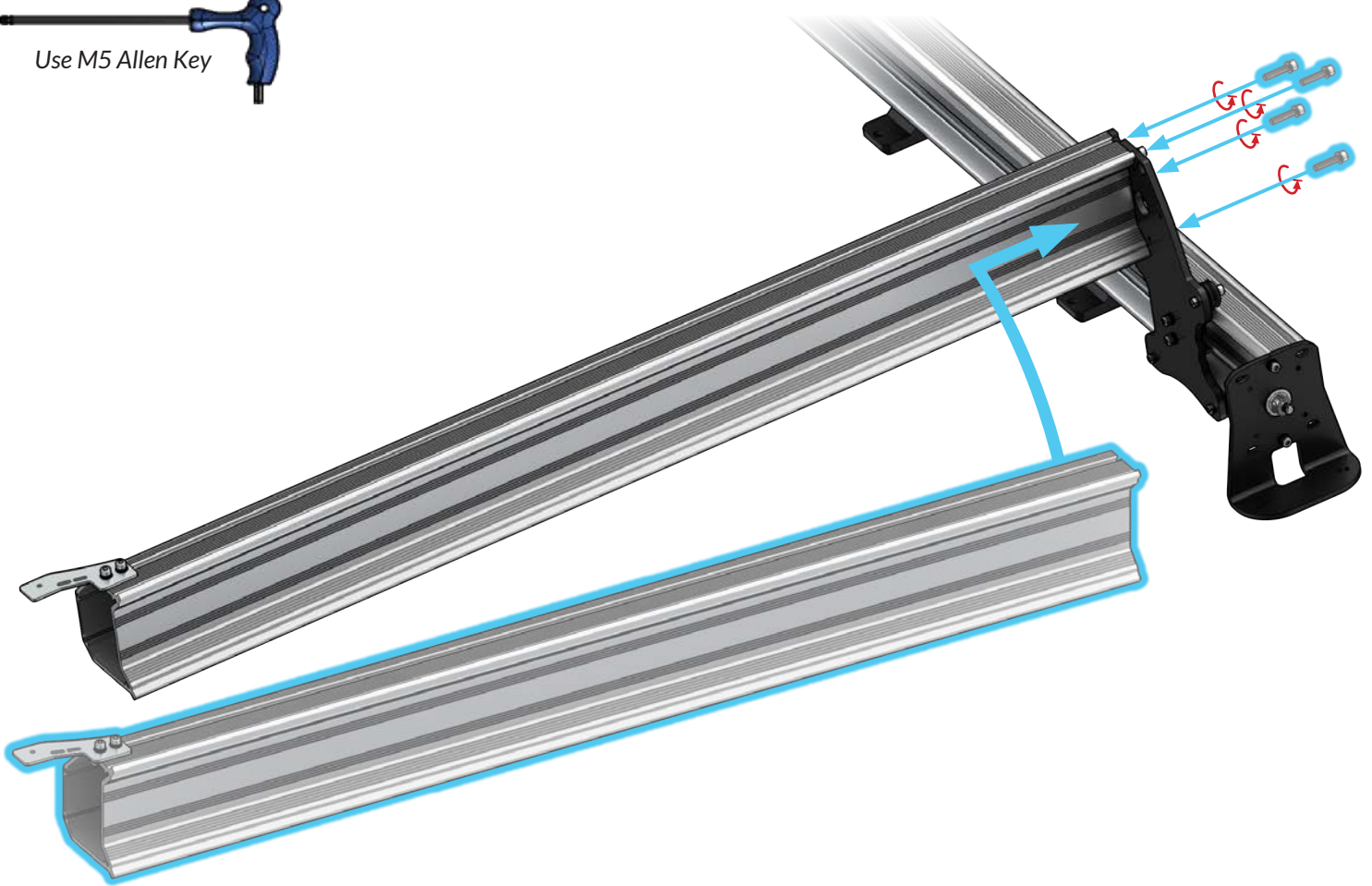

Lift the right side of the X-axis rail up to meet with the matching holes on the right Y-axis gantry plate to assemble them together. Bolt these together using four M5-25mm bolts. Positioning is easy since the shape of the rail matches the shape of the plate top.

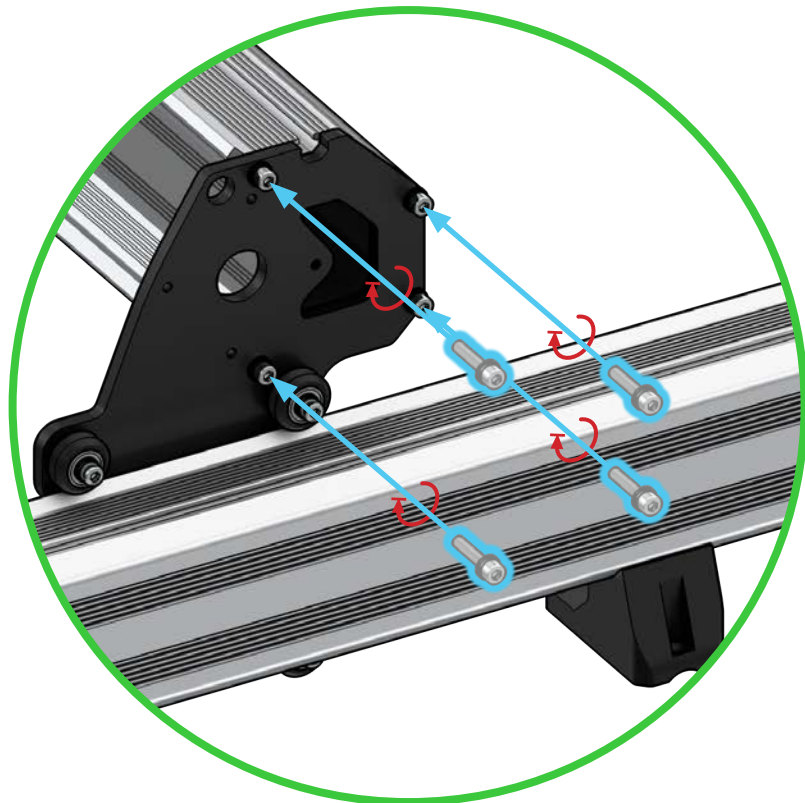

Connecting the Remaining Sub-assemblies

Parts Needed:



Previously Assembled

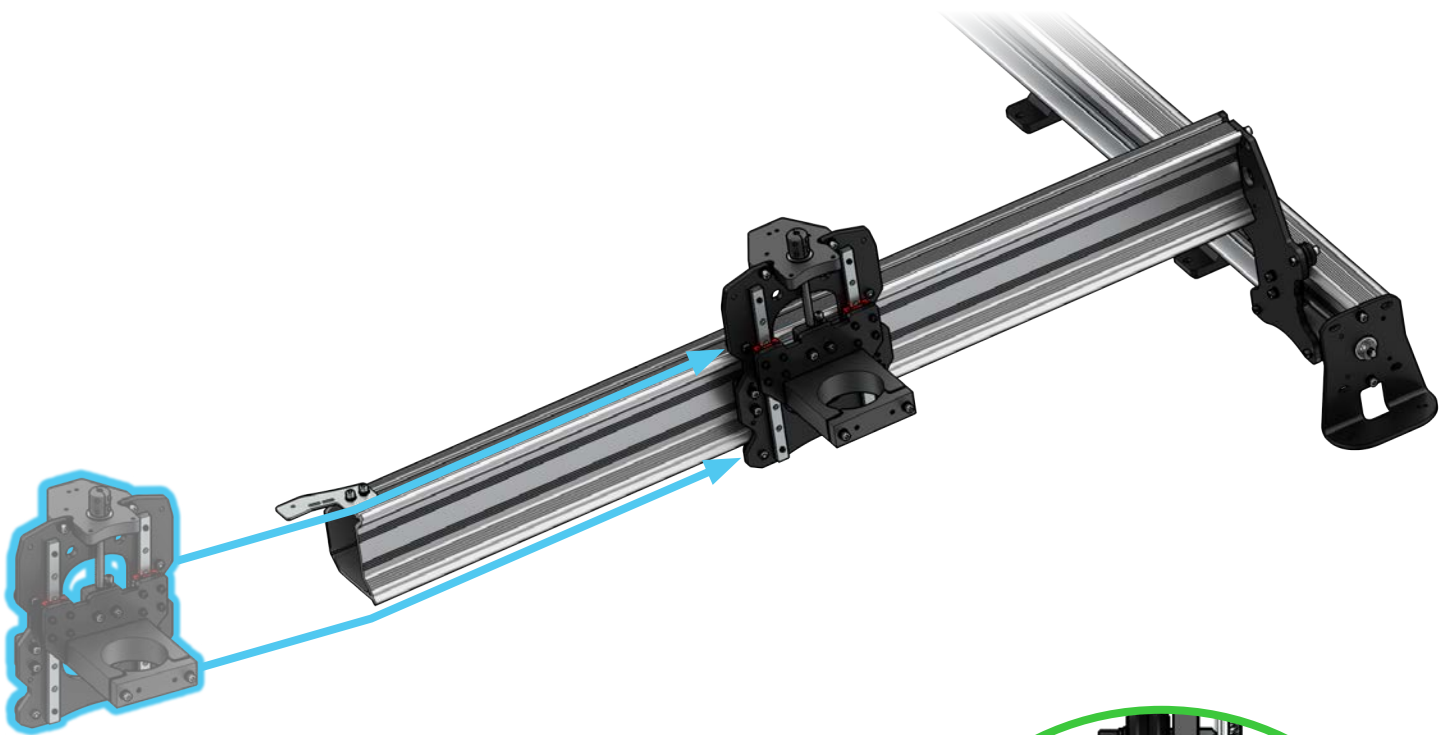
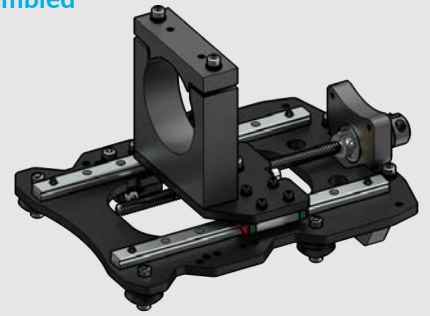

Slide the XZ-gantry onto the X-axis rail. The v-wheels should sit on the pointed edges on each side of the X-axis rail (pictured).

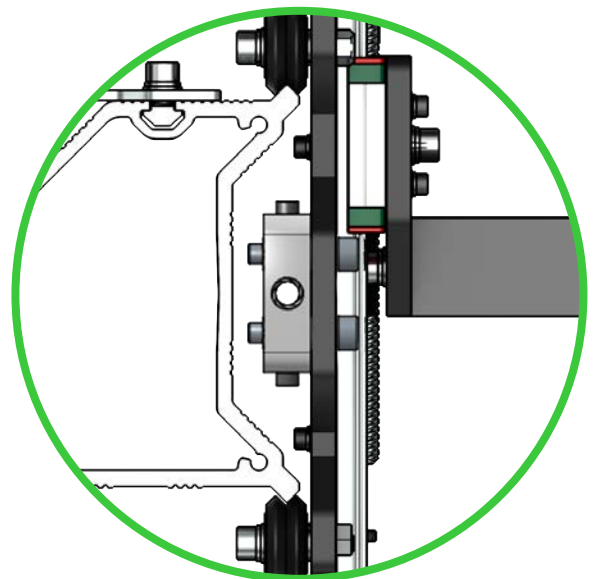

Delrin wheels rolling onto the X-rail



Use M5 Allen Key

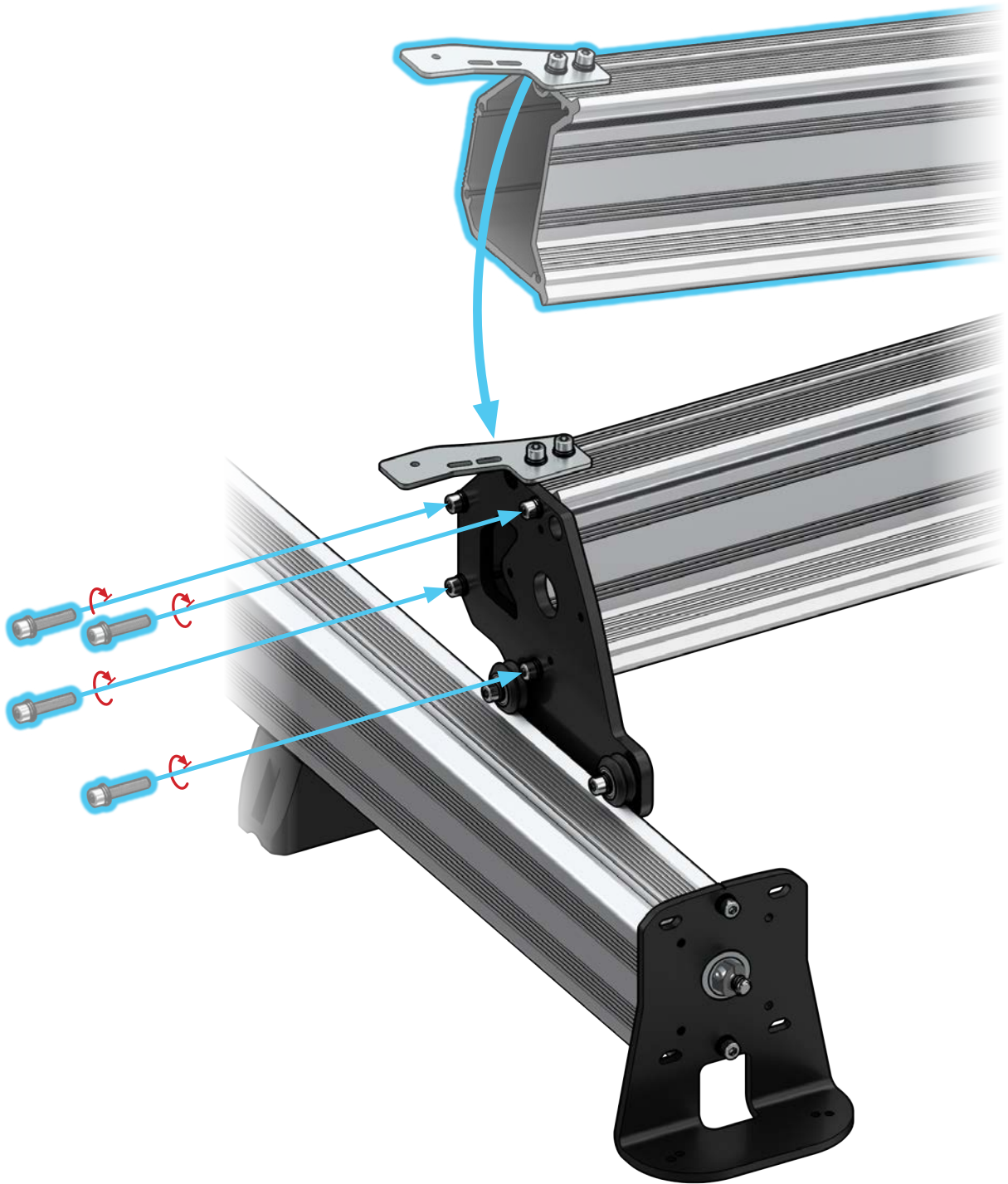

Lift the left side of the X-axis rail up to meet the left Y-gantry assembly. The drag chain mount is there to assist you with positioning by acting as a rest against the top of the plate while you bolt the plate to the rail. Fully fasten using four M5-25mm bolts.

X-axis Lead Screw

Parts Needed:

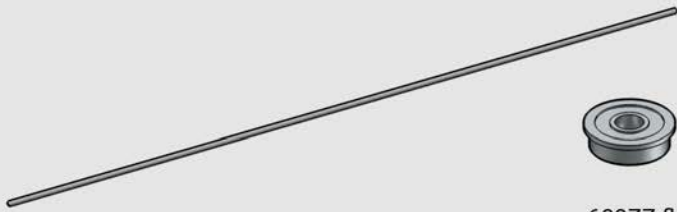

1000mm lead screw



608ZZ flange bearing
x2



6.35mm to 8mm
coupler

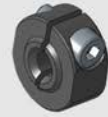

T8 clamping
ACME nut

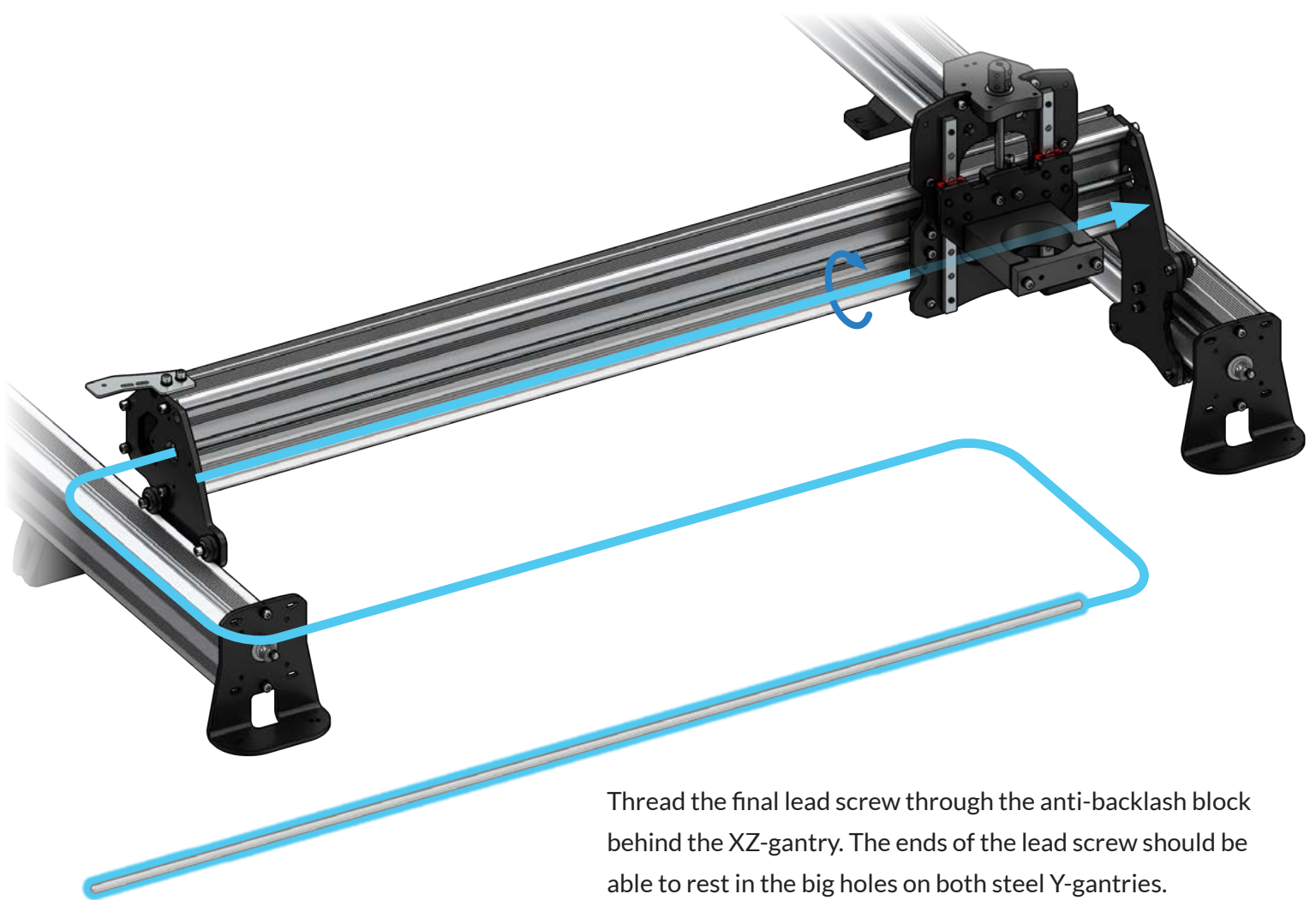

Thread the final lead screw through the anti-backlash block behind the XZ-gantry. The ends of the lead screw should be able to rest in the big holes on both steel Y-gantries.

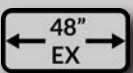

For the 48x30 LongMill, the X-axis lead screw will be installed later on, skip the following steps and move ahead to the next section [Motors & Wiring](#).

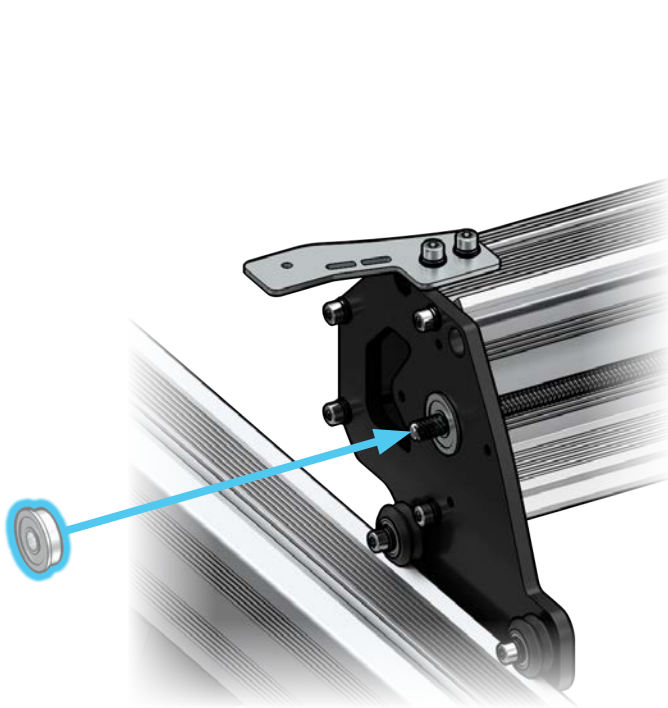

Left side

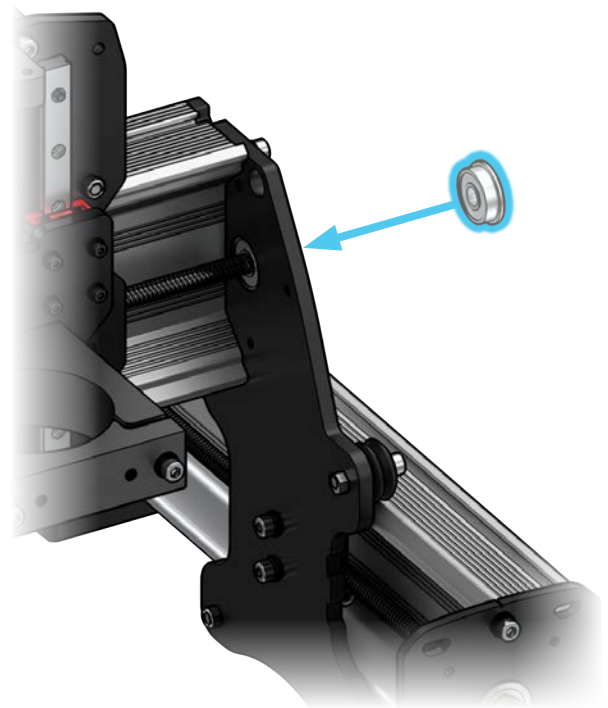

Right side

Insert one flange bearing onto each Y-gantry from the outside, making sure the lead screw goes through the bearing.

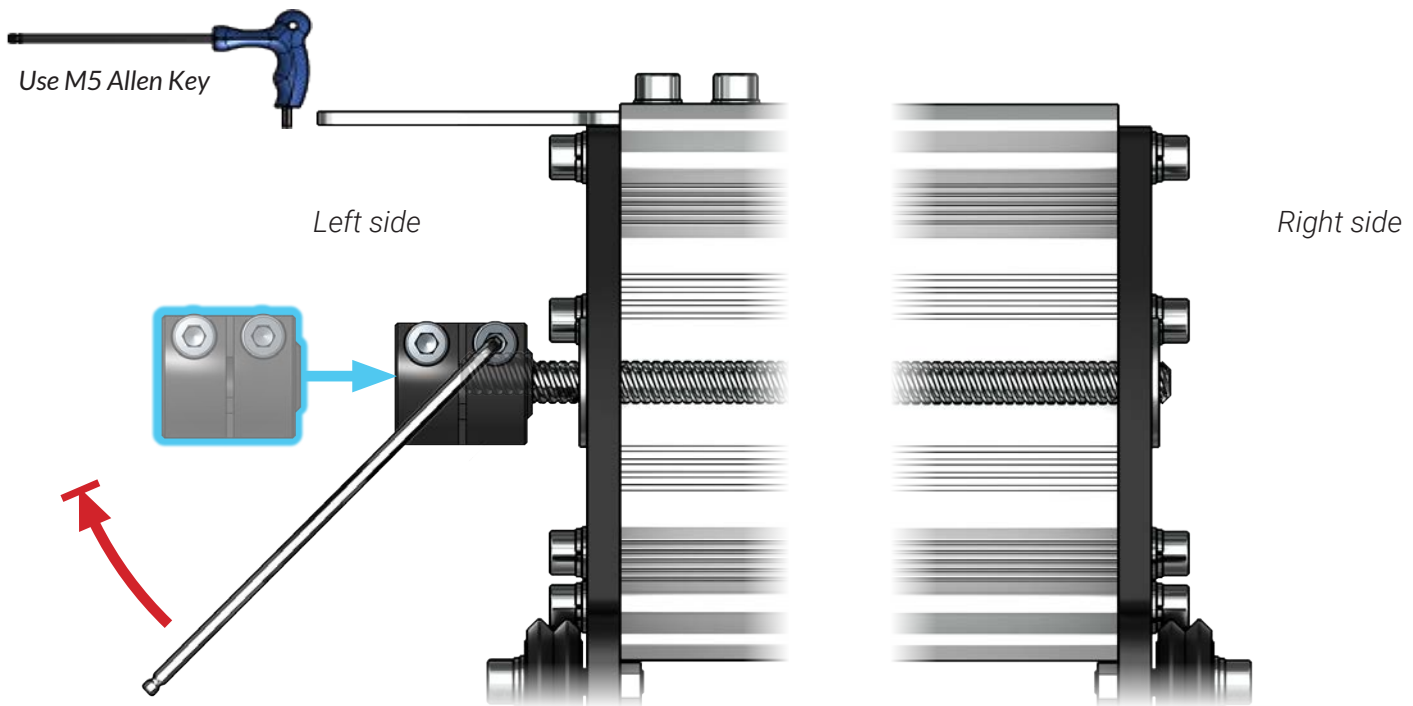

At the left side of the X-axis rail, slide the coupler on until it bottoms out on the lead screw. Firmly secure the coupler at the set screw using an M5 Allen key.

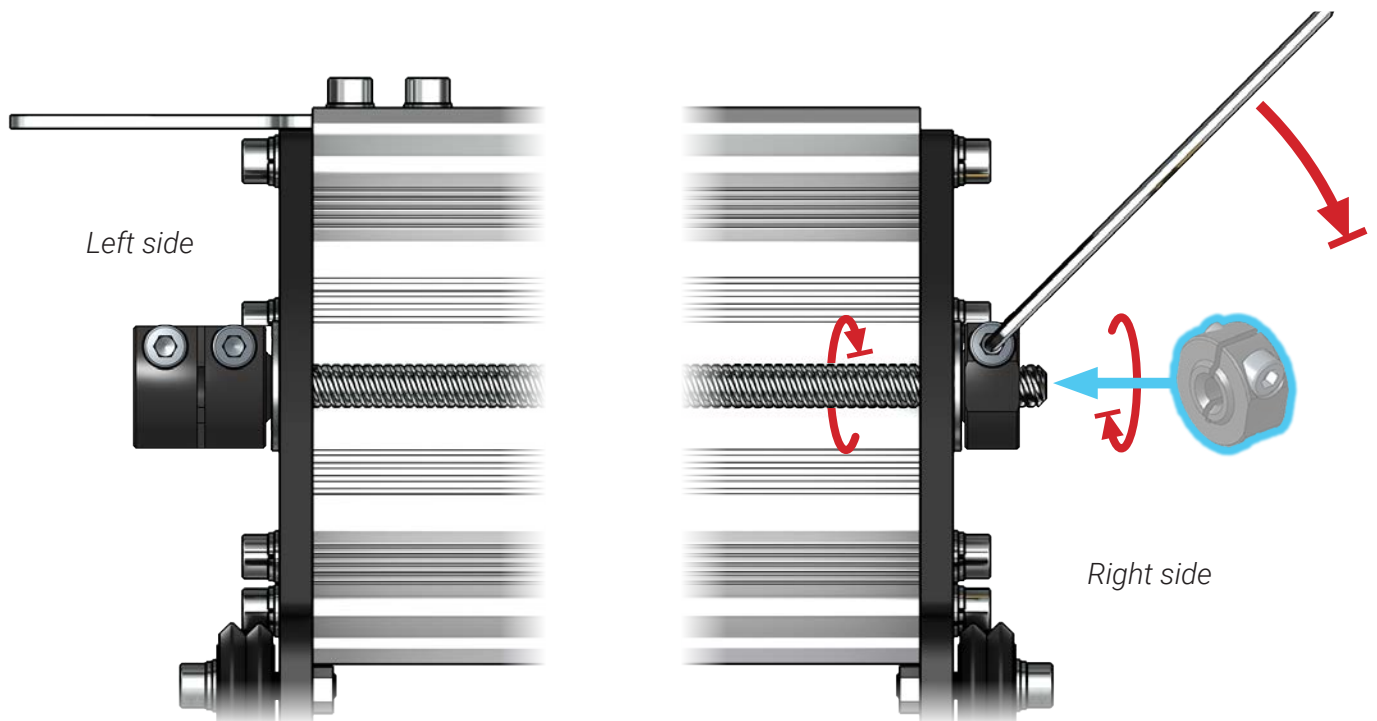

Just like for the Y-axis, use both hands on the right side to thread a locking ACME nut into the lead screw so that it pulls it flush to the flange bearing and brings the coupler flush against the other bearing. While holding this tension in place, firmly tighten the set screw on the ACME nut. This makes another 'bolted sandwich' where everything should be touching bearings (as pictured) and the lead screw should only be allowed to rotate, and not move side-to-side. **Remember**, the small shoulder for the T8 clamping nut must face the flange bearing.

Part 4 Motors & Wiring

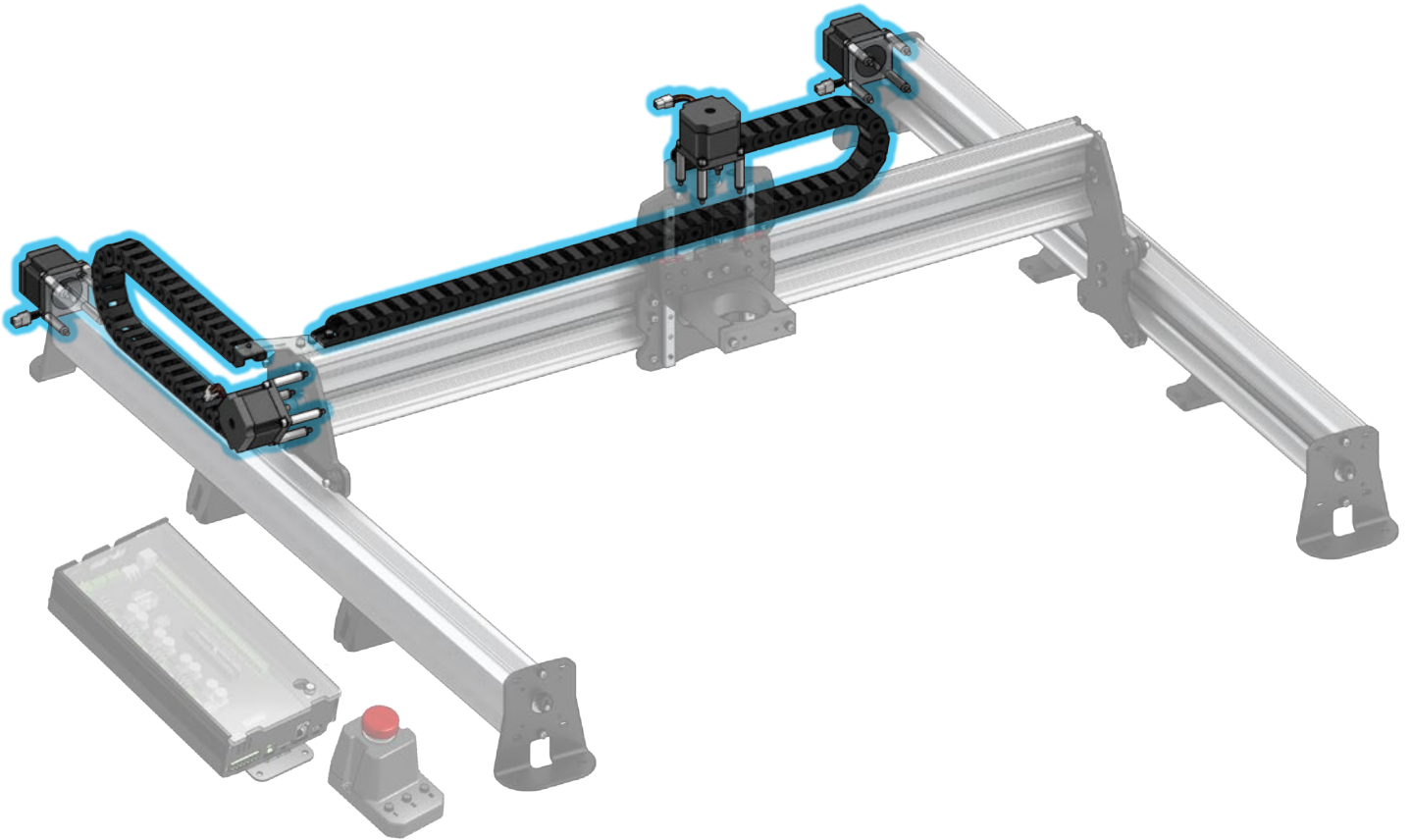

Stepper Motor Mounting

Parts Needed:

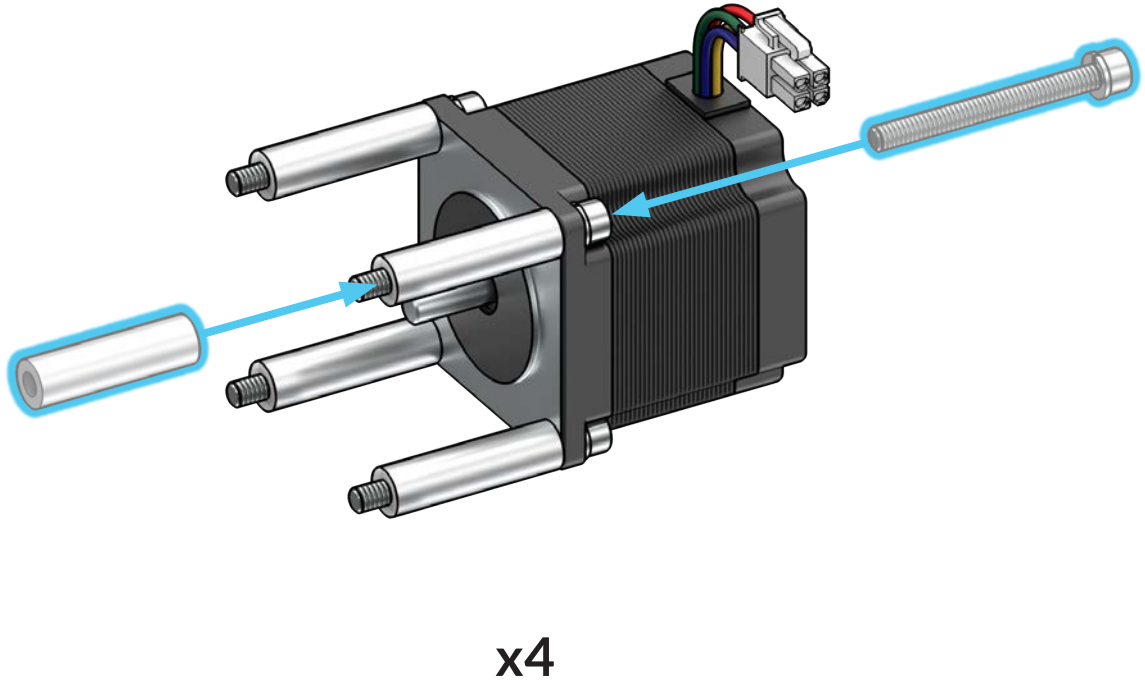
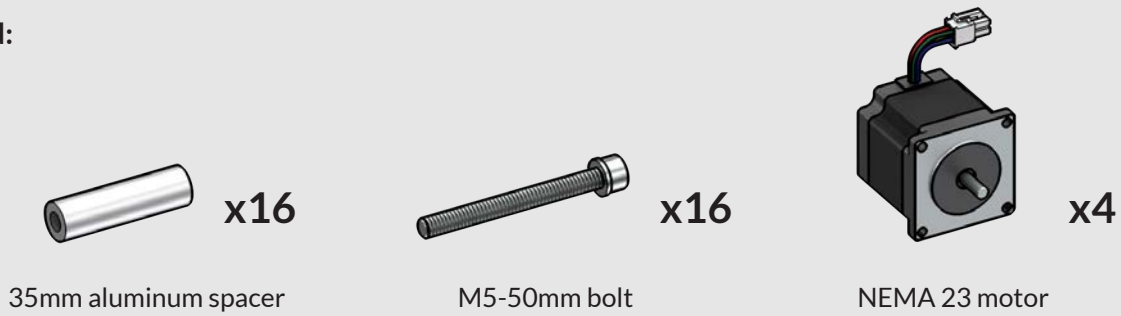

You're really making your way along, celebrate with a friend and a cold drink!! Look back to the yellow bag and grab the 35mm spacers, M5-50mm bolts, and also grab the NEMA 23 stepper motors out of the motor box. You'll be inserting four M5-50mm bolts into the four holes on each motor, alongside an aluminum spacer. These assemblies will attach to each axis of the machine.

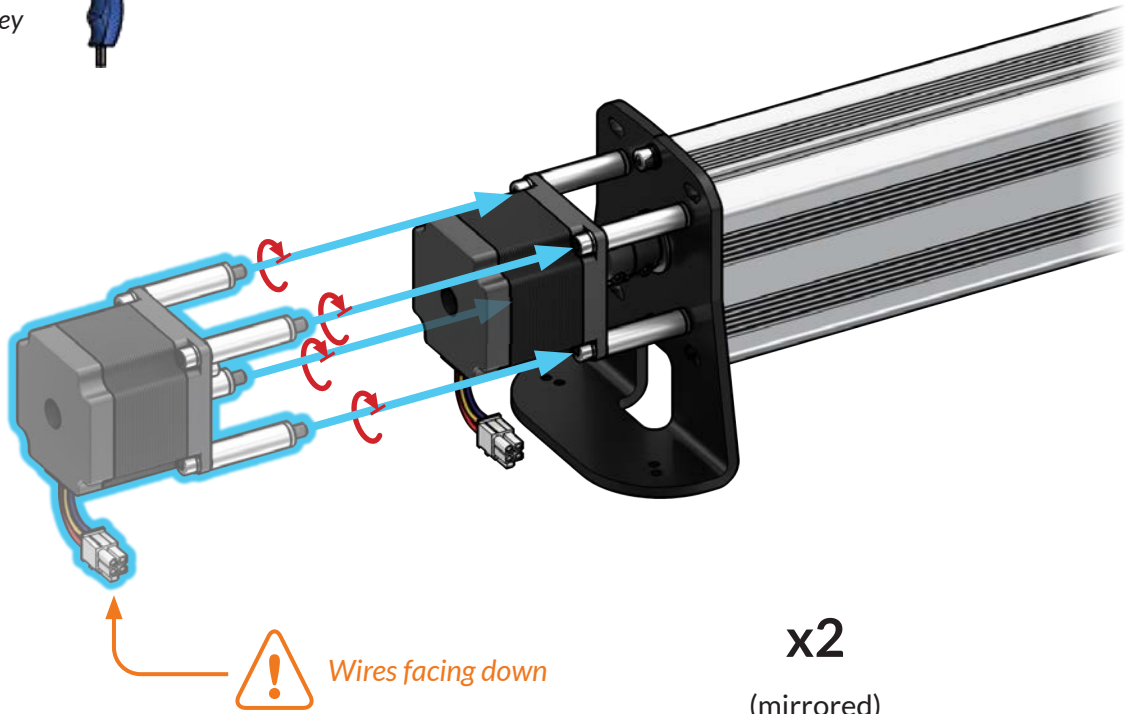

For both Y-axes, position a motor assembly at the back foot making sure the motor wire faces down. Slide the motor shaft into the coupler, then tighten all four M5-50mm screws into the foot. Once the motor is secure, tighten the set screw on the motor side of the coupler (pictured).

If everything has come together well so far, you should be able to now check that the lead screw can spin relatively easily. If you find that the motor **shaft doesn't fit into the coupler** it's likely that you tightened the motor-side set screw earlier on and have now deformed it. There is a chance for fixing this: take the motor-side set screw out of the coupler and insert anything thin like a box knife, putty knife, or paint scraper into the vertical slot of the coupler. Then screw in the set screw from the opposite side until it hits the inserted object. Rotate it against the object a couple turns to open up the slot again, then back the screw out again, remove the object, and reinsert the screw back to where it should be.

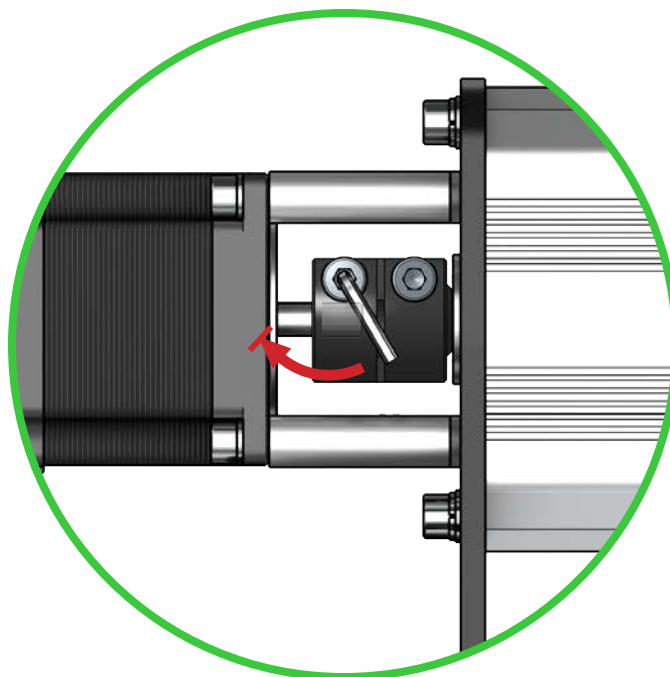



 Wires facing back and up

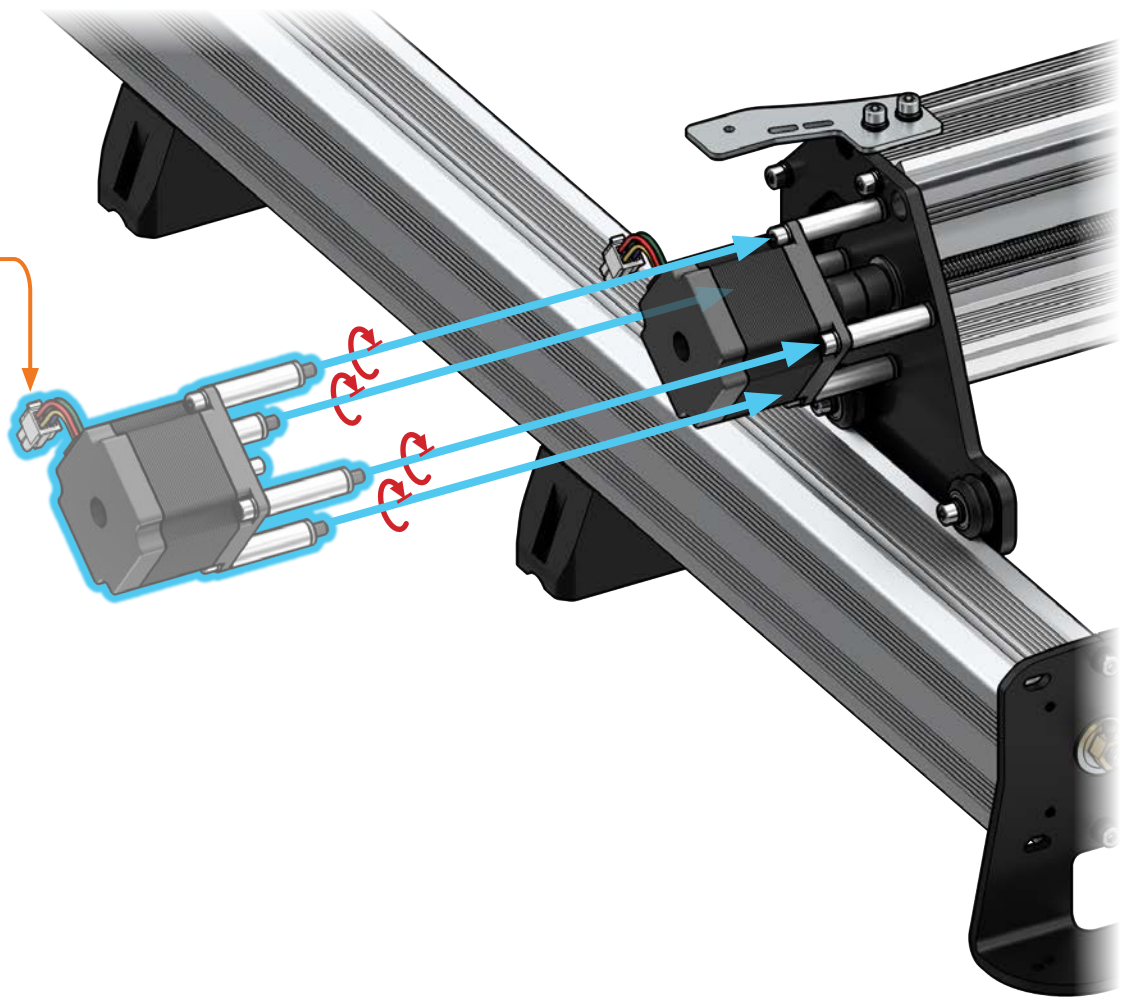

Bring a motor assembly to the left Y-gantry plate making sure the motor wire faces back and upwards (pictured). Slide the motor shaft into the coupler, then tighten the four M5-50mm bolts into the gantry. At the coupler, tighten the set screw at the motor side and ensure the lead screw can spin without excessive force.

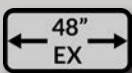
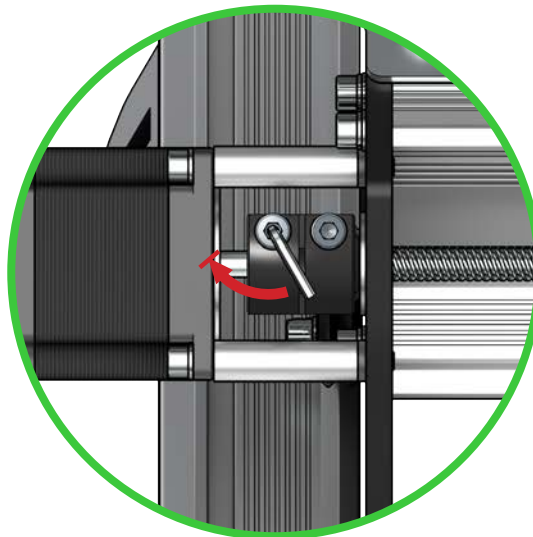

For the 48x30 LongMill, go to section E [“EX lead screw assembly”](#) and then return here once you’ve completed this step.



Use M5 Allen Key



Wires facing to the back

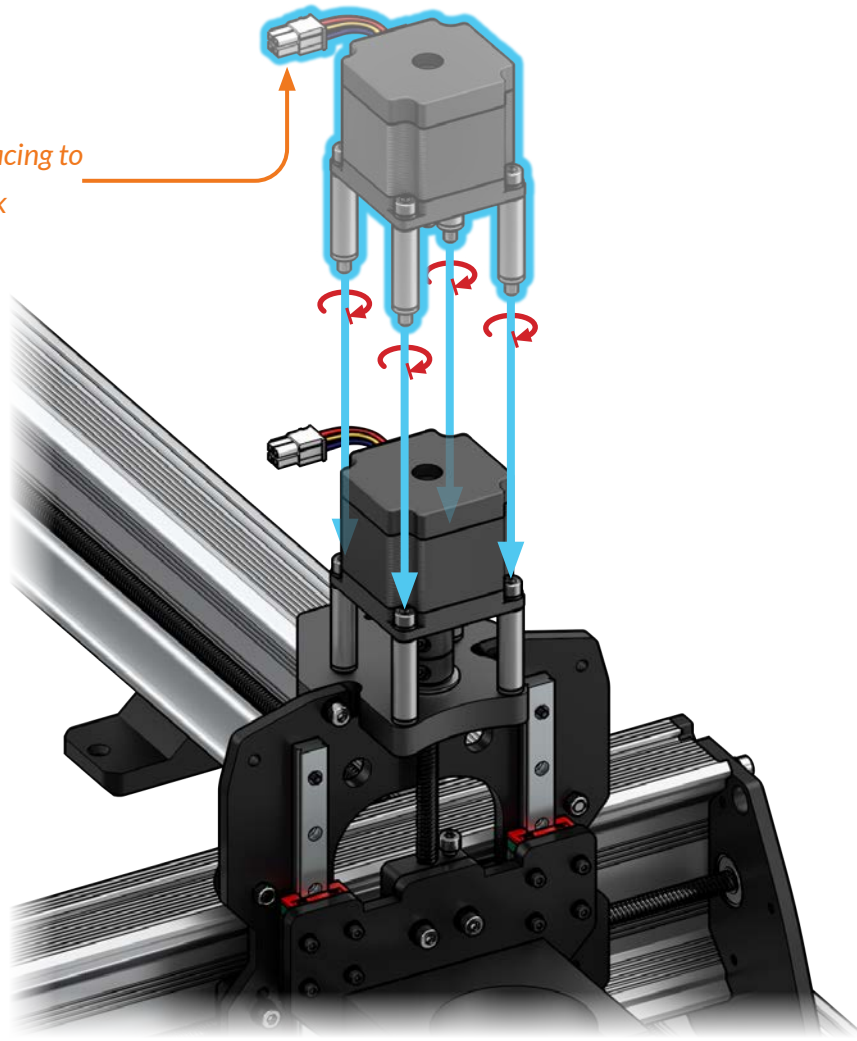

Bring the last motor assembly to the Z-axis motor mount making sure the motor wire faces backwards. Slide the motor shaft into the coupler, then tighten the four M5-50mm bolts into the motor mount. At the coupler, tighten the set screw at the motor side and ensure the lead screw can spin without excessive force.

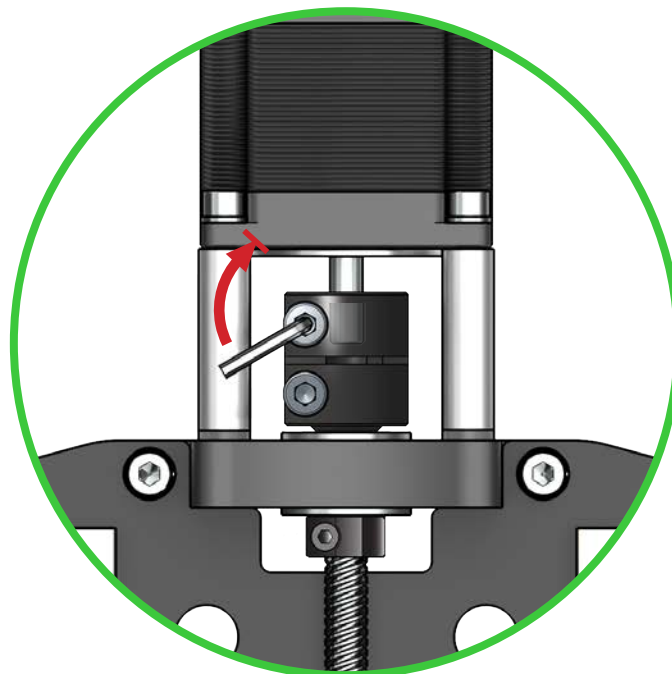

Attaching Drag Chain Ends

Parts Needed:



x4

M5-10mm bolt



x2

T-nut



Chain aligner

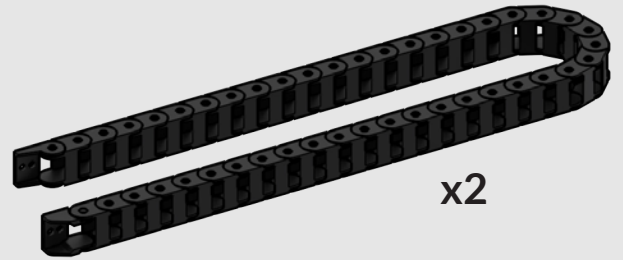

x2

Drag chain

We will now be installing the drag chains which can be found in the long rail box inside the Y-axis rails. These contain and guide the wires on the LongMill so they aren't in the way during cutting. They also keep wires from wearing out from bending or being cinched around corners. If you're assembling the 48x30 size LongMill, you'll find the second drag chain inside the "drag chain & cable box".

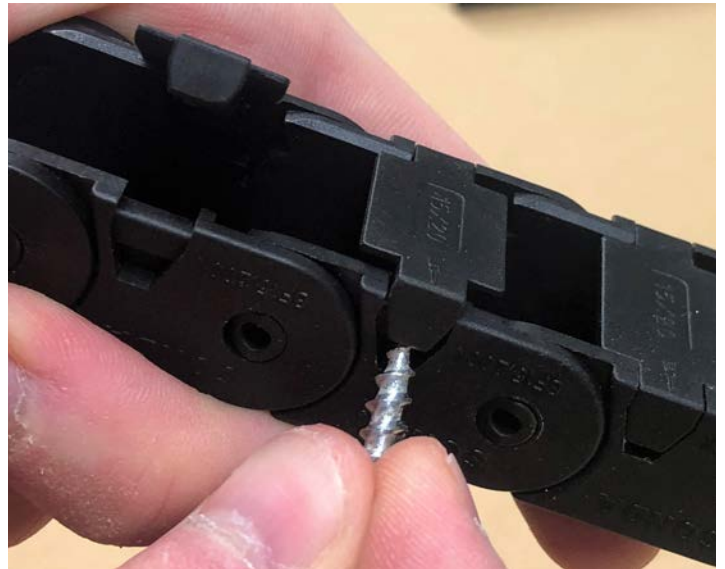
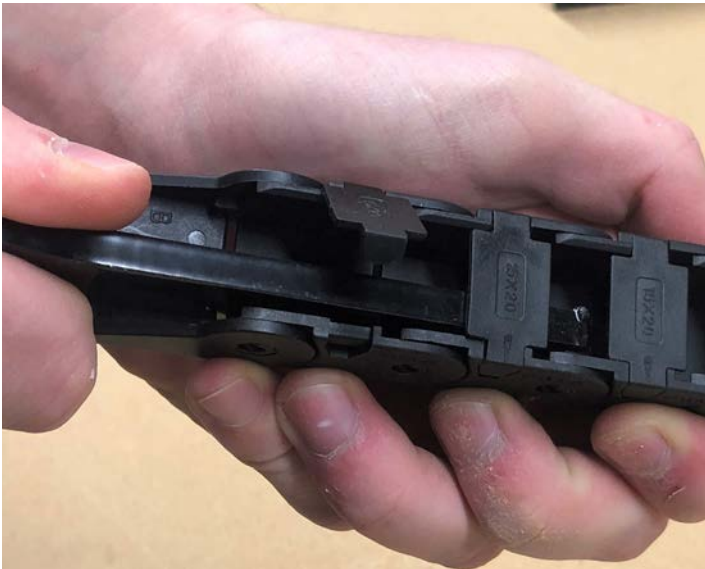

Start by unclipping all the drag chain clips using a flat head screwdriver or anything else sharp like a wood screw underneath the clip tabs. These hold the wires into the chain but can open or be completely removed, giving flexibility to add or remove wires on your machine when needed. If you're struggling with this the LongMill wrench also has a taper that can help you open them.

We recommend permanently removing every other clip if you plan on adding more wiring in the future since accessing the wire will take half the time and the chains will still work fine. Stick the extras into a baggy to save for later if you wish.

Now, remove the end links from both sets of drag chains. For the pin-type link (left picture), squeeze it together then twist and pull to disconnect it. For the hole-type end link (right picture), pull on one side of the link then twist it away to separate it. A flat head screwdriver or thin shim can also be handy for this, just be careful not to cut yourself.



Do this for all four end pieces, two hole-types and two pin-types, and set them aside.



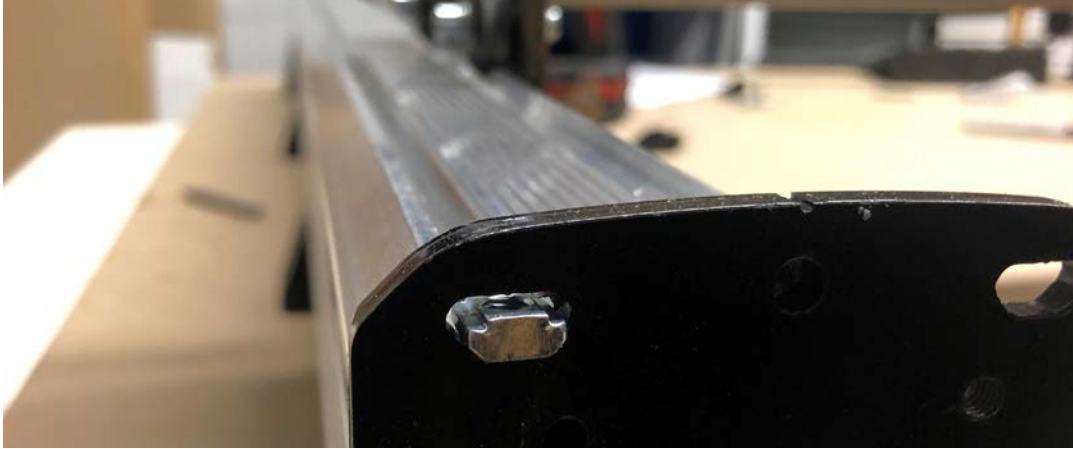

Grabbing the bag of t-nuts and M5-10mm bolts, we will attach these end links to the machine starting with the left Y-axis. Slide a t-nut onto the Y-axis rail through the hole in the front foot.



You'll want to position it a little further back than halfway on the rail for both machine models (30x30 pictured).

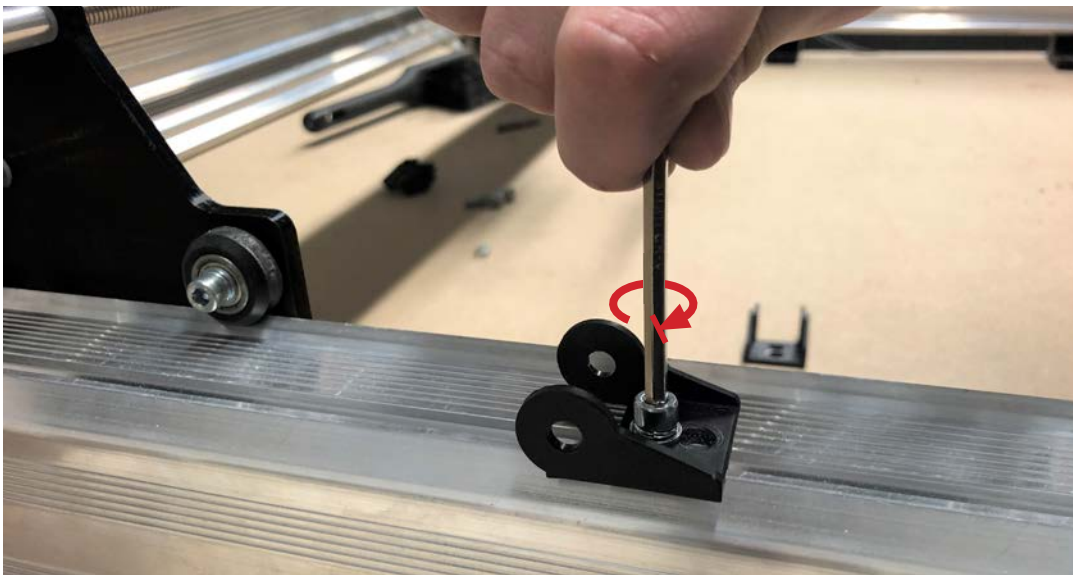

Once in position, use an M5-10mm bolt to fasten a **hole-type** end link in place with the M5 Allen key (pictured).



Now get a **pin-type** end link (pictured) along with the 3D printed chain aligner from the yellow hardware bag to mount the other end of the drag chain. The printed aligner has a nub that will align to a hole in the end link (pictured).



These will attach to the drag chain mount from the underside with another bolt.

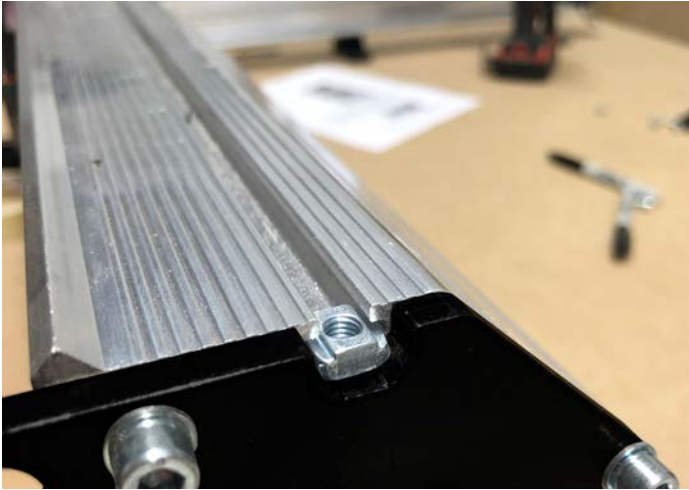

On the X-axis the process will be repeated. Slide in a t-nut through the hole in the right Y-gantry and bring it all the way to the left side next to the drag chain mount where you'll bolt in a **pin-type** end link. Ensure the end link is snug up against the drag chain mount (pictured)

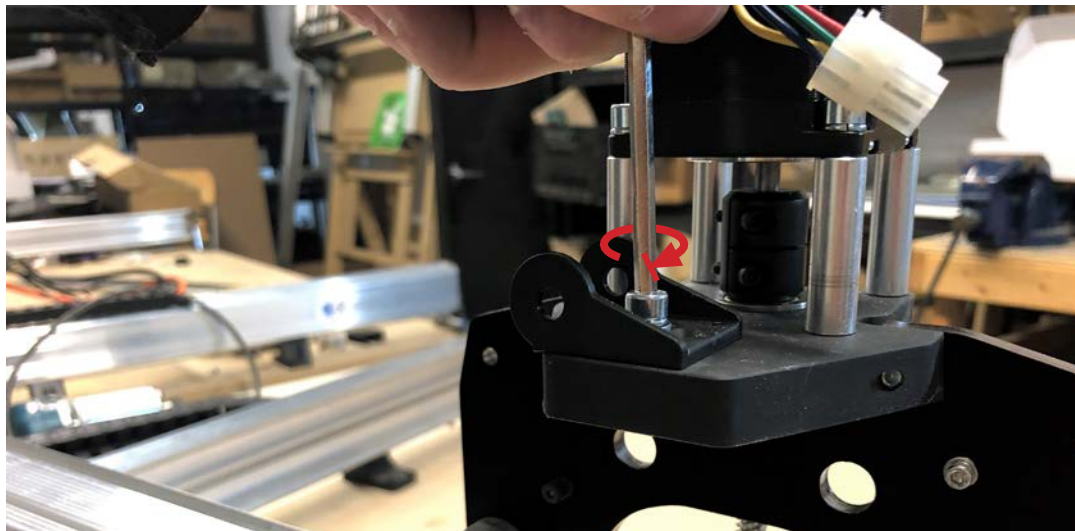

Lastly, attach the final end link onto the Z-axis motor mount using one last bolt to the inner hole. Note the direction the link is facing.

Routing Wires

Parts Needed:

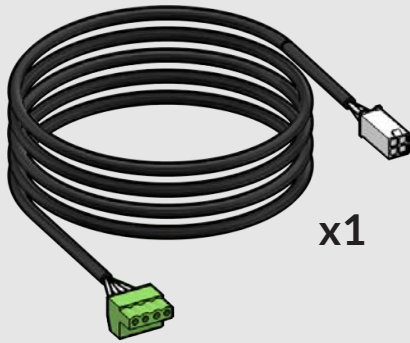

x1

Long motor cable

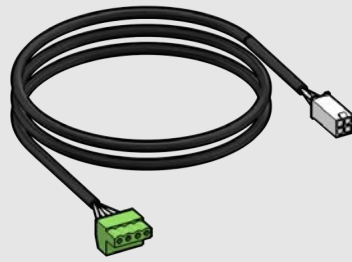

x3

Motor cables



Router

For the remaining assembly you won't need any more of the loose hardware except for the provided wood screws. If you want, take a second to clean off your space and feel free to stick all the extra remains into a box for later use or maintenance on your machine.



Before we attach the drag chains back onto the end links we'll be moving around a couple links to get the right fit. To do this, put your hands on either side of the link you want to break, then twist and pull them apart to disconnect. Set aside the remaining, unused links - they can come in use if you're planning on upgrading to a larger sized LongMill later.

Depending on the size of LongMill you have, remove and add links to each drag chain as follows:

- For the 12x30 LongMill, remove **16 links** off of the Y-axis drag chain and add **3 links** onto the X-axis chain.
- For the 30x30 LongMill, remove **13 links** off of the Y-axis drag chain and add **3 links** onto the X-axis chain.
- For the 48x30 LongMill, remove **13 links** off of the Y-axis drag chain and leave the longer X-axis drag chain at its original length.

This will make it so the chains are the correct length to travel the whole range of motion of the machine while also staying as short as possible to maximize the wire length going to the controller.



At this stage, it's a good idea to grab the router you'll be using with your machine. We'll show these steps using the Makita RT0700 / RT0701 trim router that we recommend (pictured). Also, grab the motor wires from the motor box while you're at it.

Note: when using the Makita RT0700 / RT0701 it'll come with a base attached. Remove this as you'll just need the main router body for the CNC.

To mount your router, loosen off the mount's front bolts until it slides in. Place it nearly all the way down with the power cable facing left and rotated slightly backward (pictured) then tighten back up to secure it. Go back and forth between the two bolts to keep equal clamping force and make sure not to over-tighten them.

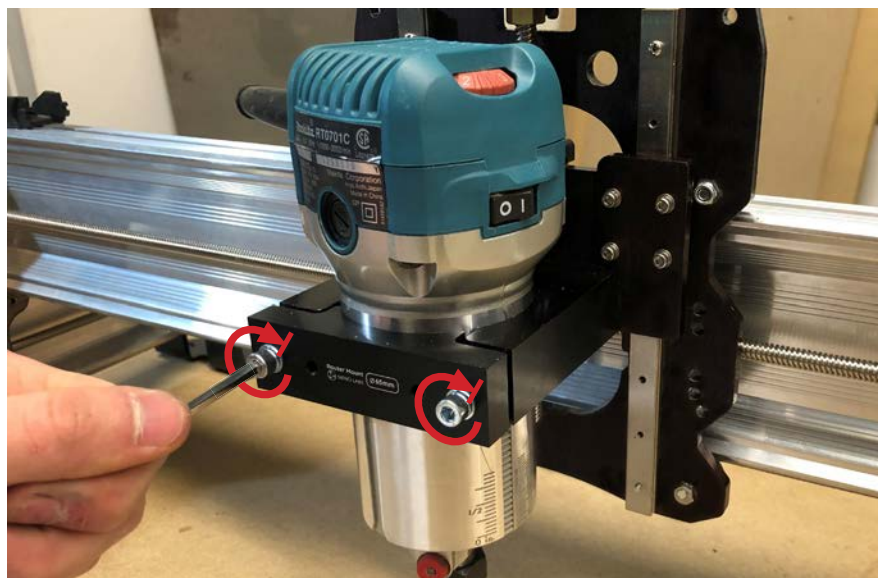

Confirm the angle by turning the Z-axis lead screw by hand until its upper limit – the blue part of the router body shouldn't collide with the Z-axis motor mount at any point. You can adjust the router height later depending on your setup: lower if you use tiny tools on thin material or higher if you use longer tools on 3-4" thick material.

This maximum position is also where you can access the 4 bolts holding in the router mount from behind for future swapping or tramping. You'll simply lift up the drag chain and go through the hole in the X-gantry, being mindful not to damage the aluminum rail edge with the Allen key.

Optionally use the top left hole on the X-gantry as a zip tie point to keep your router wire out of the way during operation. To set it up right, move the Z-axis all the way down and then zip it on with some extra slack still available (pictured).

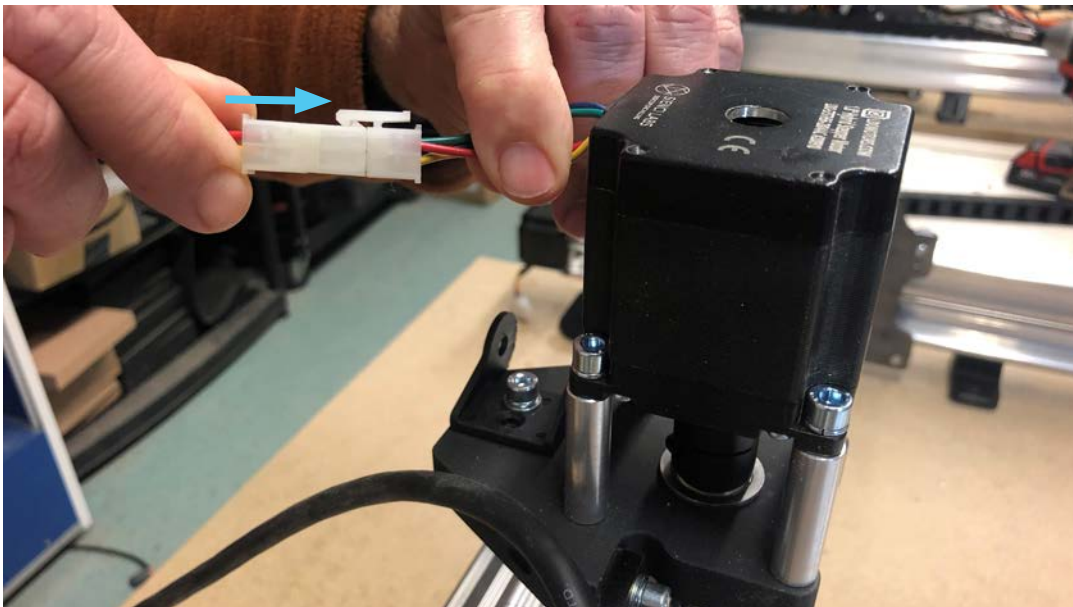
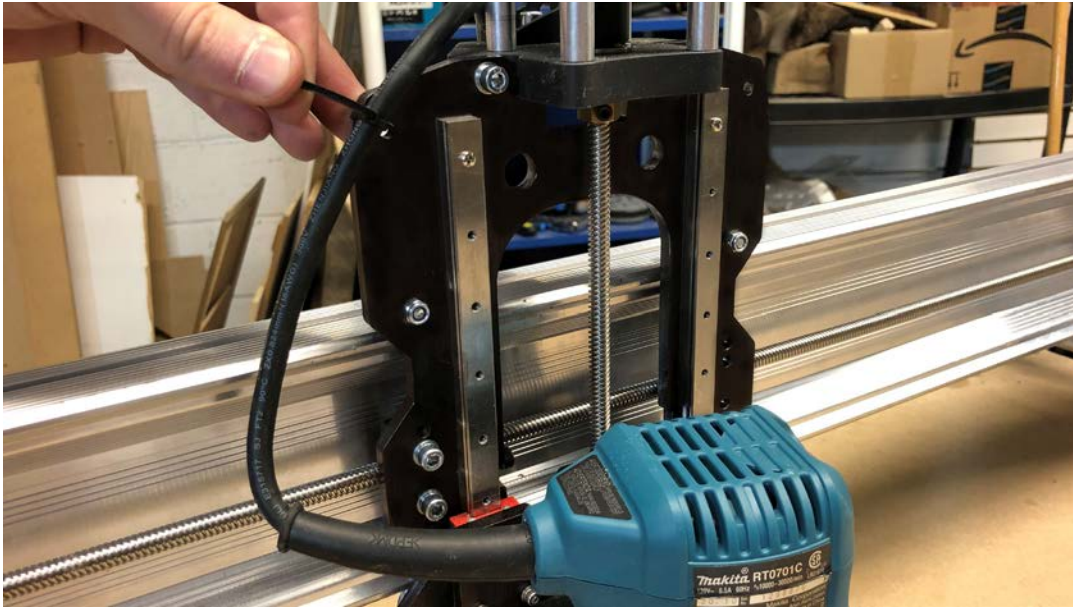

Now onto the remaining wiring. Grab the **long motor cable** and connect it to the Z-axis NEMA 23 motor. The connector can only go in one way, so find the orientation where the connector attaches with ease.

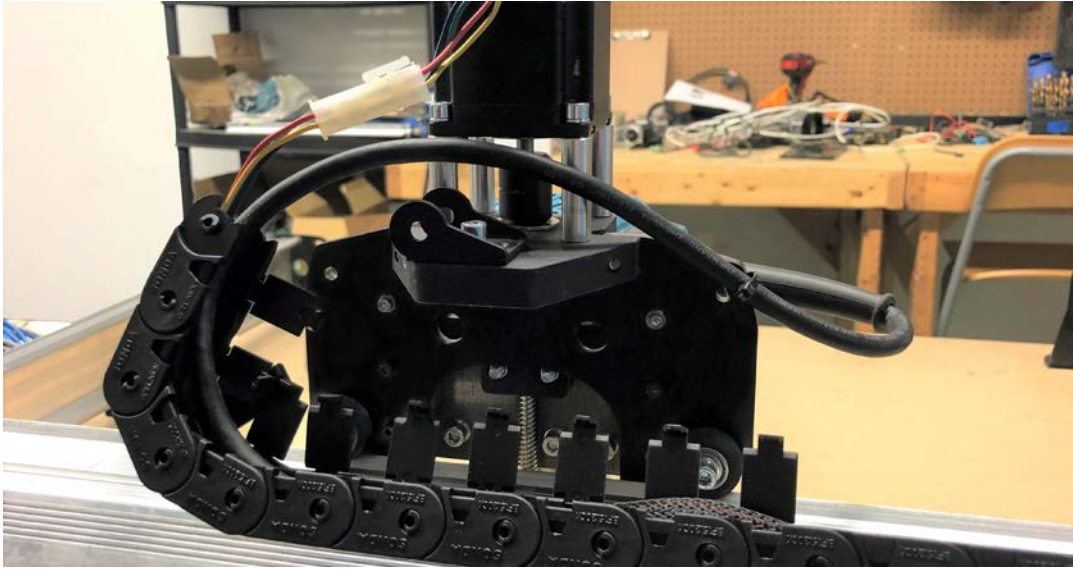

Grab the drag chain for the X-axis (the longer one) and seat in the Z-axis motor cable and router wire. Ensure you have the correct end of the drag chain so it'll attach onto the end link and bend in the right direction. Reattach it onto the end link and start to re-clip the clips into place.

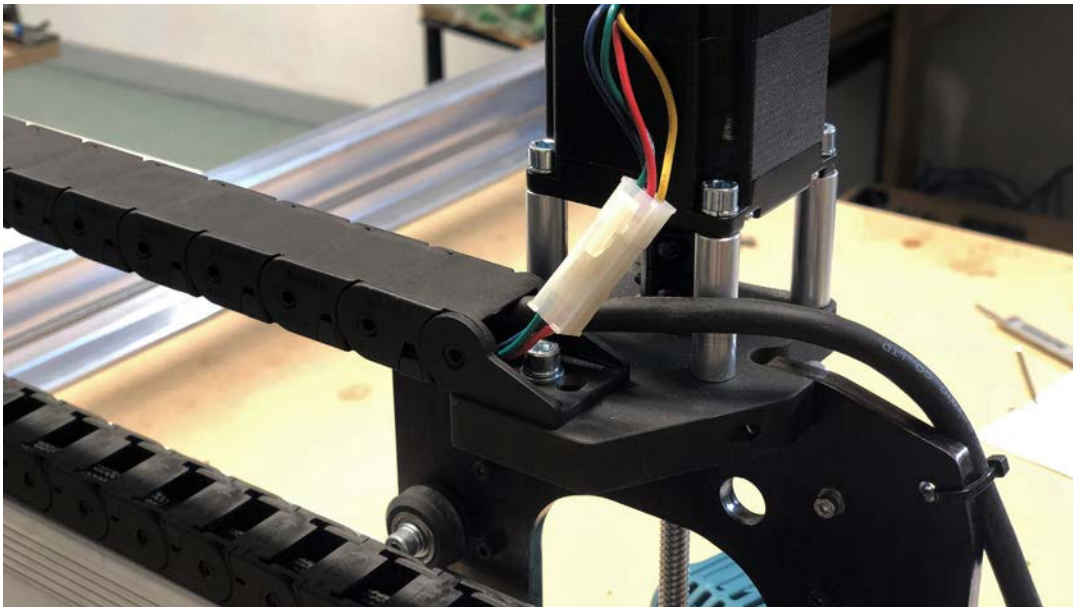

Note: if you purchased the limit switch add-on kit you'll want to leave enough clips open that running the wires for the switches later on will be easier to do.



Leaving the last few clips open, bring the other end of the drag chain around and attach it onto the other end link on the X-axis rail. Pull the wires through and around the drag chain mount and finish closing the remaining clips.

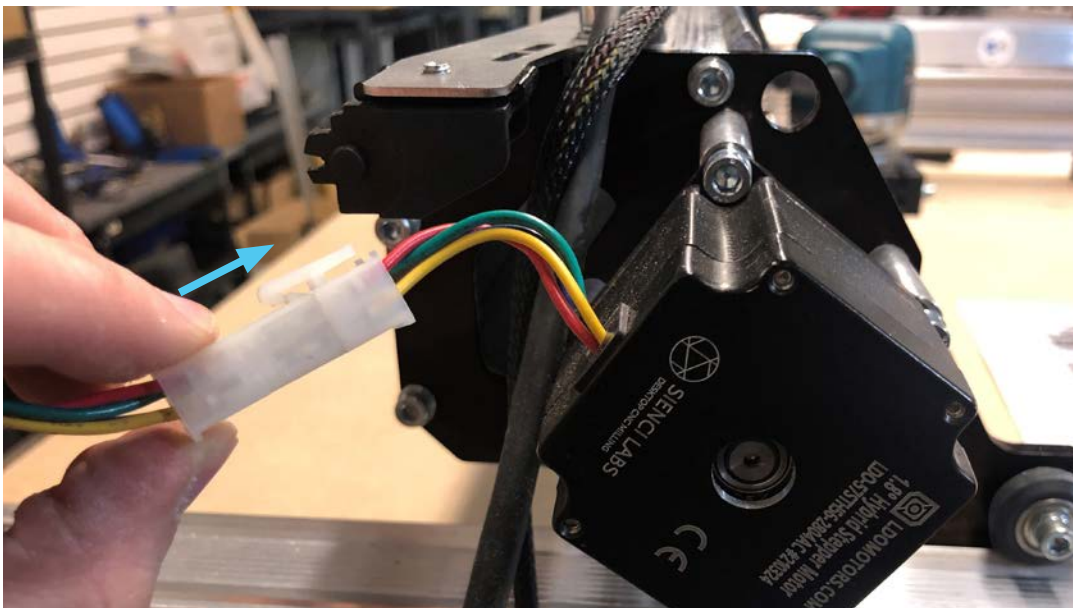

Attach a motor cable onto the X-axis NEMA 23 stepper motor.



Take the X and Z-axis stepper motor cables and the router cable and insert them into the Y-axis drag chain. Keep in mind the bend of the drag chain and attach it, clipping in the wires to secure the wires.

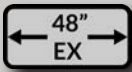

For the 48x30 size LongMill go to section F "[Cable extension installation and routing](#)" and then return here once you've completed that step.

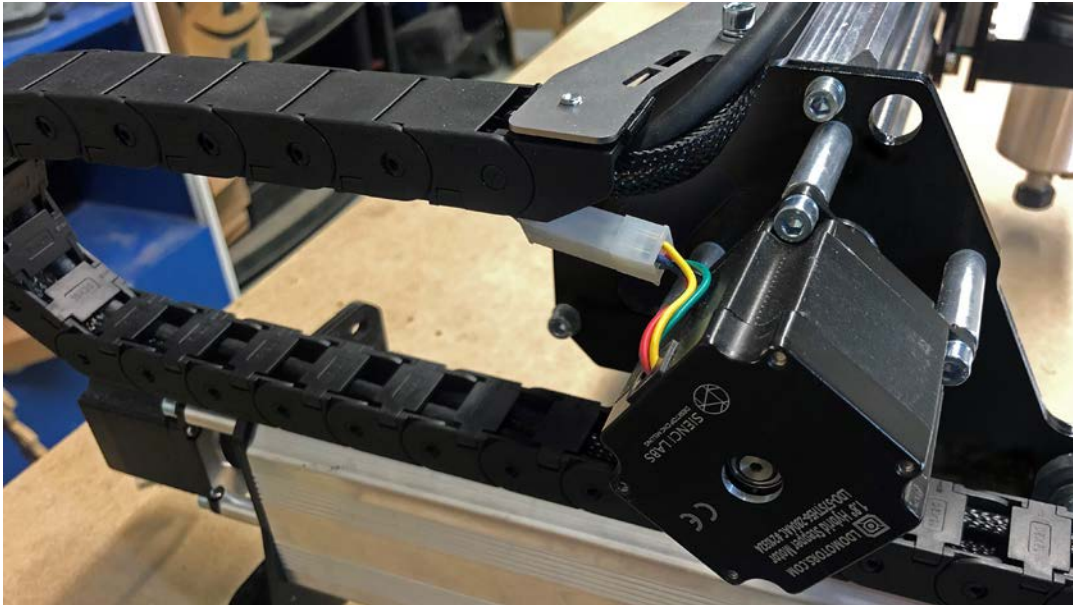

Bring the other end of the drag chain around and attach it onto the other end link on the Y-axis rail. Pull the wires through and off to the left side of the rail and close the remaining clips.



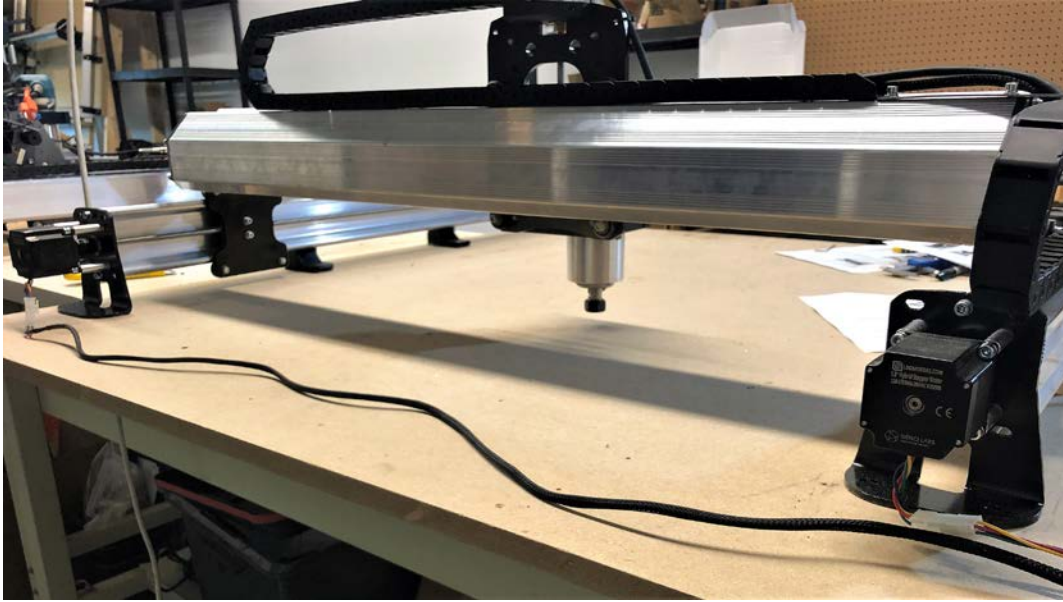

Lastly plug in the cables for the motors on the two Y-axis NEMA 23 stepper motors.



Bring the cables around to the left of the machine so they're now all bundled together (pictured). You'll be plugging the motors cables into the control box shortly but otherwise the machine wiring is now complete!

Part 5
Checks & First Moves

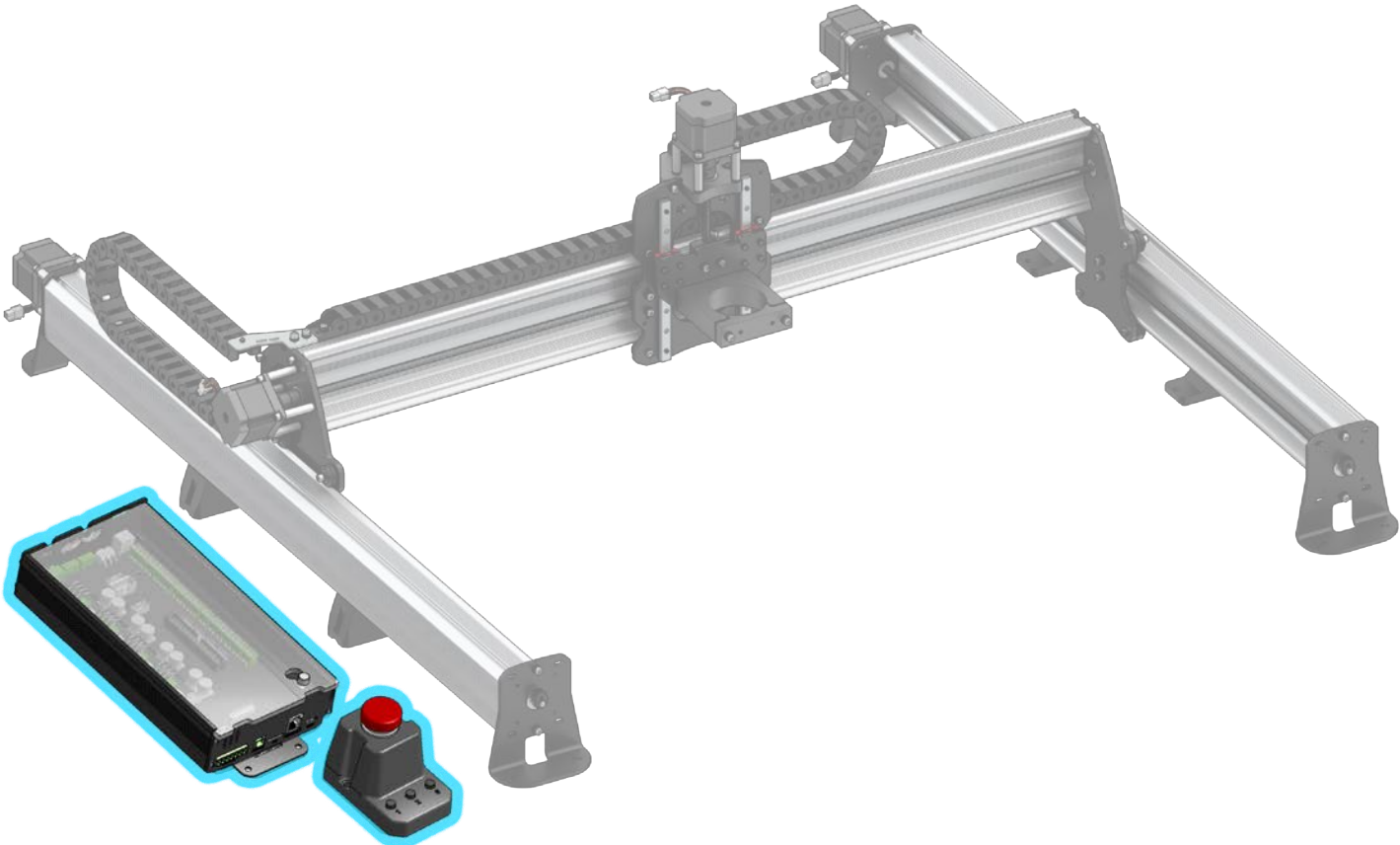

Checking & Plugging In

Parts Needed:



E-stop



Control box

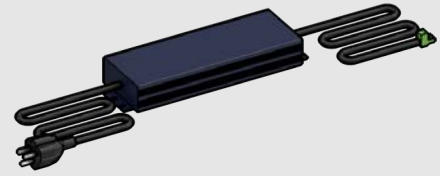

Power supply

The LongMill electronics come pre-assembled and are pretty much ready to go out of the box. Here are two things you can double-check before plugging in and powering-on.

First, check all wires going into green connectors by tugging on them. This includes the wires to the green motor connectors, green connector from the power supply, and the green connector coming from the E-stop button. Secure them using the screw terminals and a flat head screwdriver if they're loose or the wires come out entirely.



Small flat head used



Second, confirm the wire order for the power supply and motors. It's important that the DC power brick has a **white** or **red** wire on the left side and a **black** one on the right when the screw terminal is facing you (as pictured).

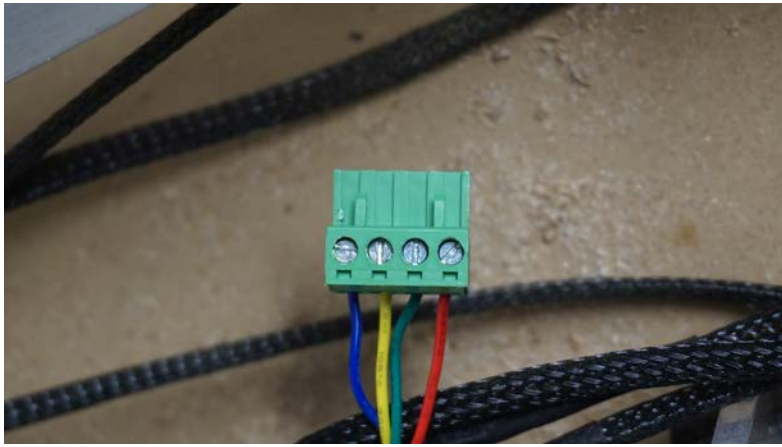

For the motor connector the wires, looking down from the side with the screw heads, should be, from left to right, **BLUE, YELLOW, GREEN, RED** (pictured). Check if the color pattern on all four of your motor wires is correct and rearrange them if needed.



With these checks done, let's remove the cover on the SLB. Twist the thumb screw in the top right corner counter clockwise to loosen it a bit, then slide the cover to the right.





This will allow the thumbscrew to pass through the keyhole. Pull the cover up from the side and you will reveal the motor plugs and all the internal connections.

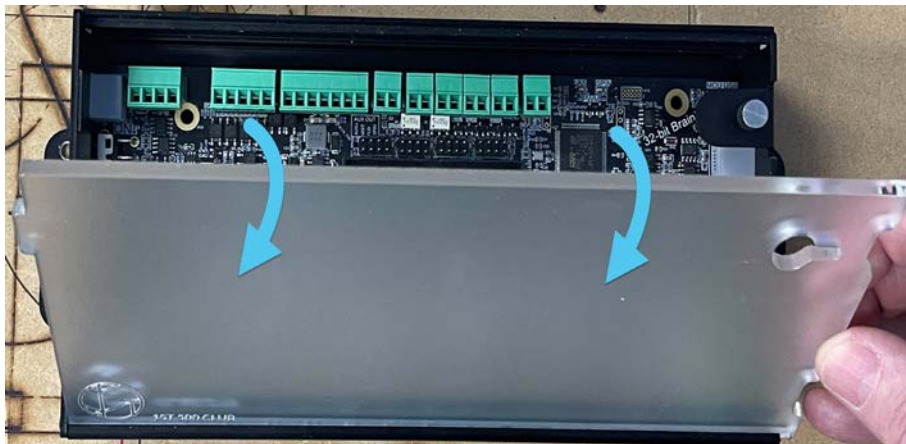

With the cover open, start connecting the motors. Track each cable from each motor to its corresponding green connector and connect it to the board. The fit of these connectors is tight but you need to be sure to push them ALL THE WAY IN so that there is good contact between the plug and the connector. Each plug on the board is labeled on the top (note that there isn't a difference between the Y1 and Y2 plugs, the Y-axis motors can be connected to either of them).

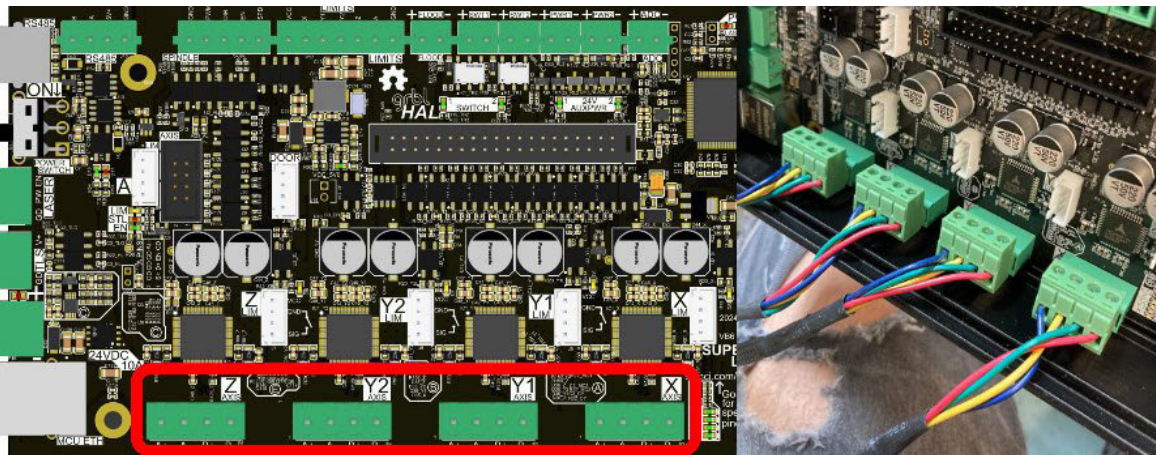

Next, plug the connector coming from the power brick into the rear of the LongMill's control box (pictured); wait until after it's plugged in before plugging the AC cable on the other end into the wall.

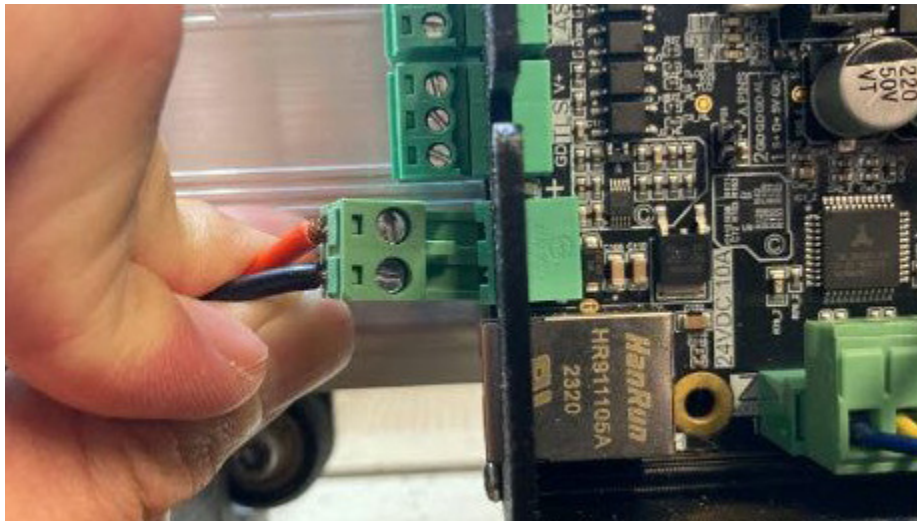

Now, connect the emergency stop button to the control box via the connector on the front. You should be able to find your E-stop button (pictured on the right) in the SuperLongBoard box.

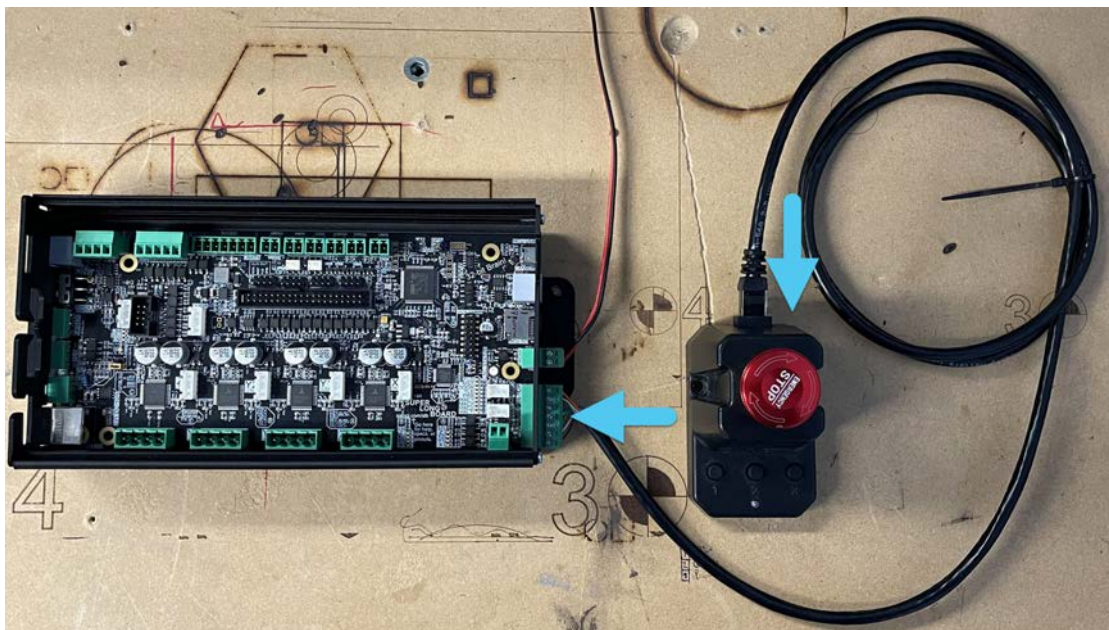

Next we will be connecting to your computer, booting up gSender and then running some quick tests.

Connecting the LongMill to your Computer

Parts Needed:



Computer



USB Cable

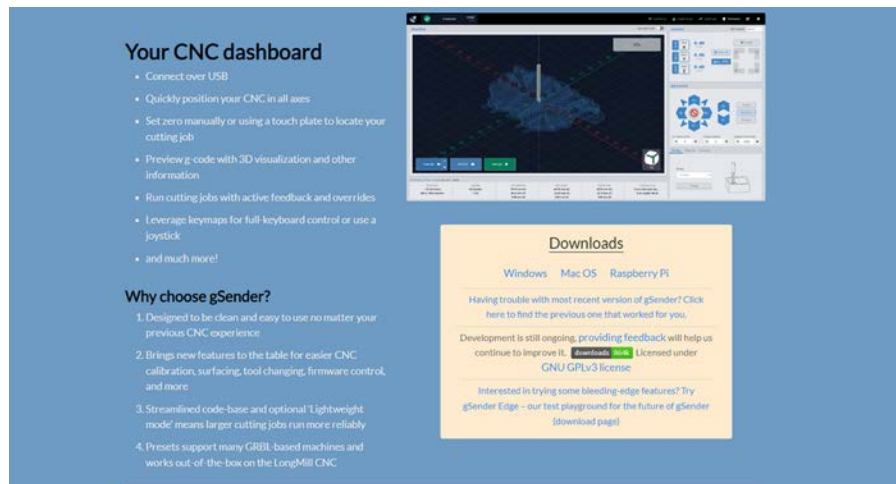

Your CNC dashboard

- Connect over USB
- Quickly position your CNC in all axes
- Set zero manually or using a touch plate to locate your cutting job
- Preview g-code with 3D visualization and other information
- Run cutting jobs with active feedback and overrides
- Leverage keymaps for full keyboard control or use a joystick
- and much more!

Why choose gSender?

1. Designed to be clean and easy to use no matter your previous CNC experience
2. Brings new features to the table for easier CNC calibration, surfacing, tool changing, firmware control, and more
3. Streamlined code-base and optional 'Lightweight mode' means larger cutting jobs run more reliably
4. Presets support many GRBL-based machines and works out-of-the-box on the LongMill CNC

Downloads

Windows Mac OS Raspberry Pi

Having trouble with most recent version of gSender? Click here to find the previous one that worked for you.

Development is still ongoing, providing feedback will help us continue to improve it. [Downloads](#) [Home](#) Licensed under GNU GPLv3 license

Interested in trying some bleeding-edge features? Try gSender Edge - our test playground for the future of gSender ([download page](#))

To manipulate your LongMill and send it files, you'll need a g-code sender which acts as the 'control software' or 'machine interface' to your CNC. We recommend using gSender for this since it's our own design geared towards hobby use, though there are other options you can see in our 'Software' resources. We'll be using gSender as the interface for the remaining assembly.

You can download gSender here: <https://sienci.com/gsender/> and choose for Windows / PC , Mac, Linux, and others. If you're not sure which type of Windows you are using, you are most likely using 64-bit.

If you get stuck at any point or want to learn more about gSender you can always reference here for more help: <https://resources.sienci.com/view/gs-installation/>

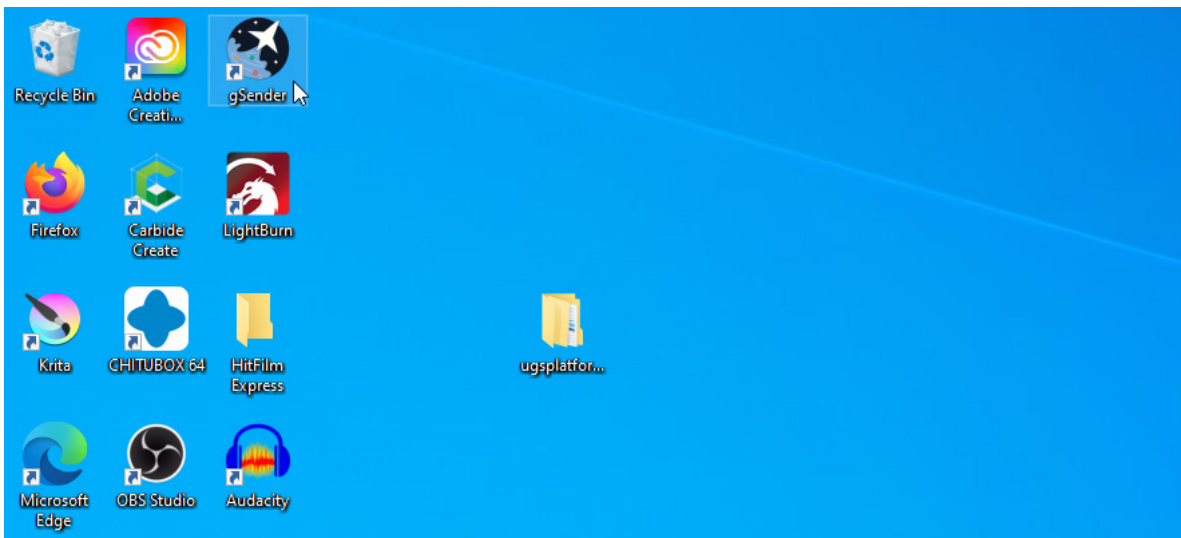

Once you have gSender installed, go ahead and run it on your computer. One way is to double-click the shortcut on your desktop.

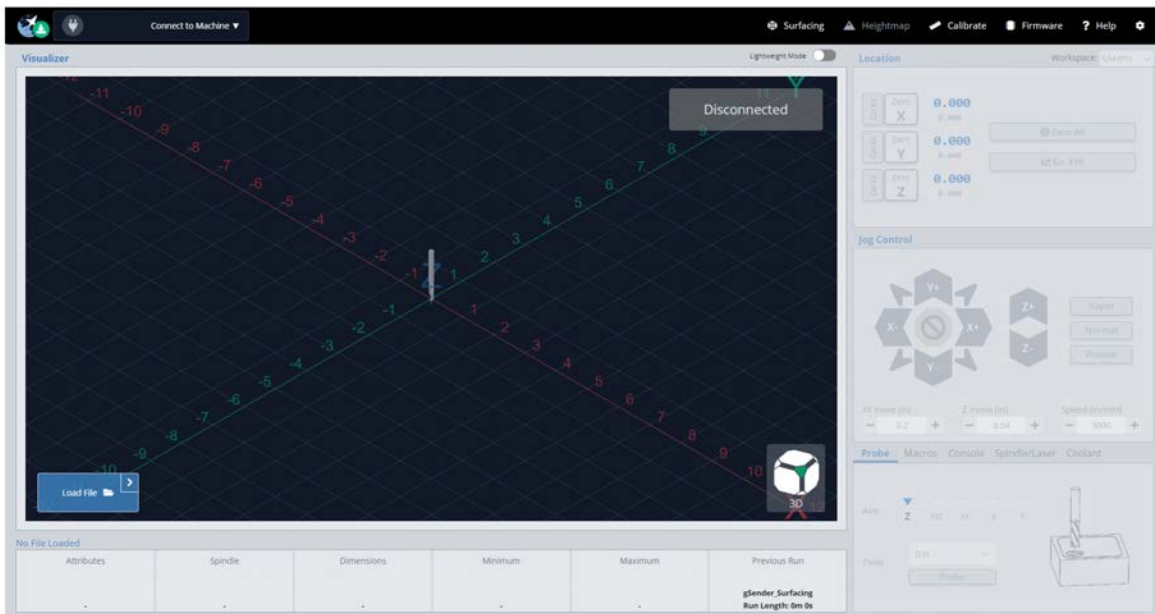

You should be greeted with a screen that looks like this.

At this stage it's time to connect your computer to the LongMill control box via the provided USB cable and **flip the power switch** to turn on power to the machine. The USB port on the control box is on the right side.

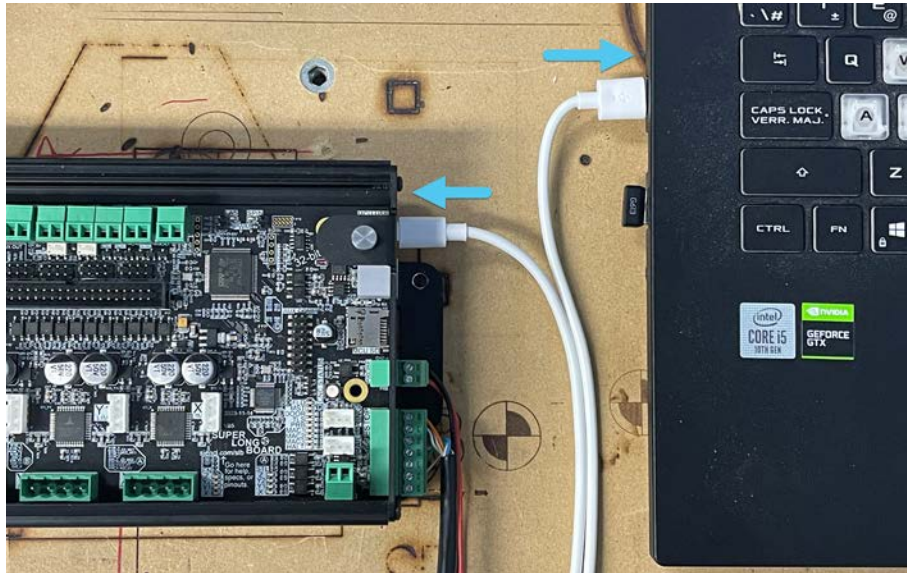

Once that is done, hover over the top left corner of the program at "Connect to Machine" (with the board powered on).



Connecting to the SLB, requires you to click the gray bar at the bottom labeled Firmware.

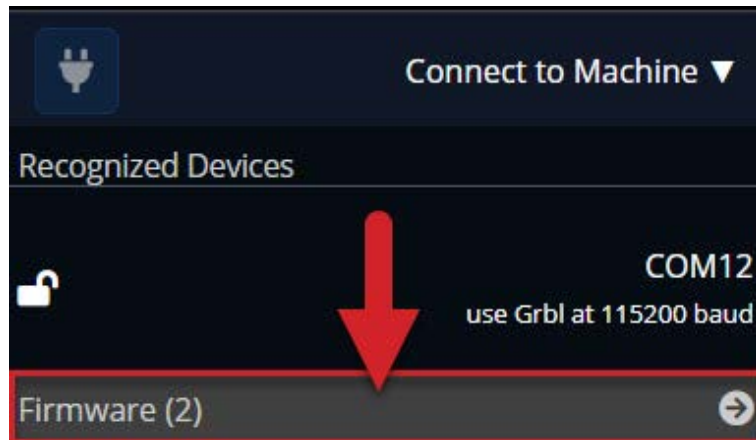

The grey area will open up, revealing two choices. We want to click on **grblHAL**.

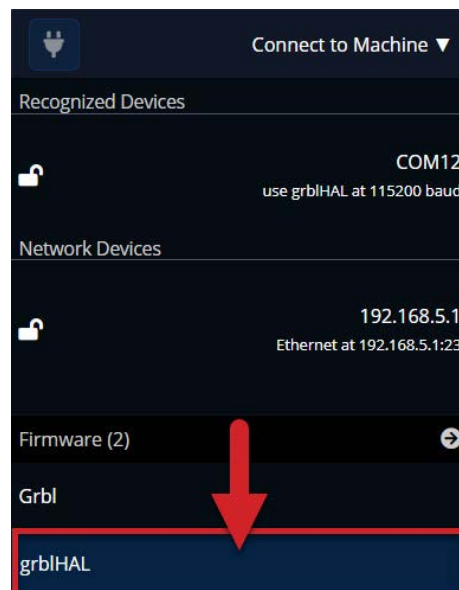

With the SLB, we have the option to connect via USB or Ethernet. Under Recognized Devices there should be one option, let's select that.

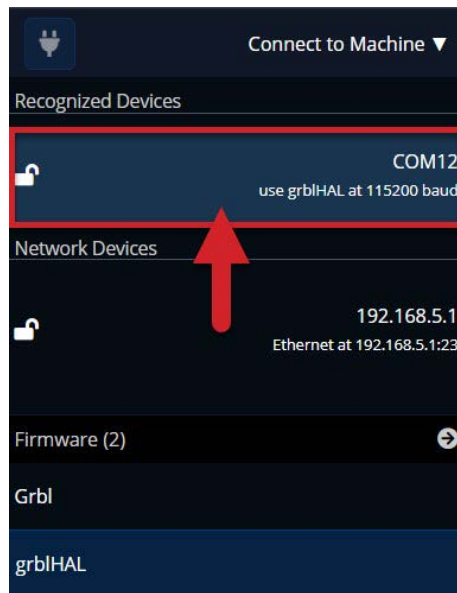

Congrats! You have connected to your new LongMill! Since USB is plug and play, we've selected it now and can connect via Ethernet at a later time.

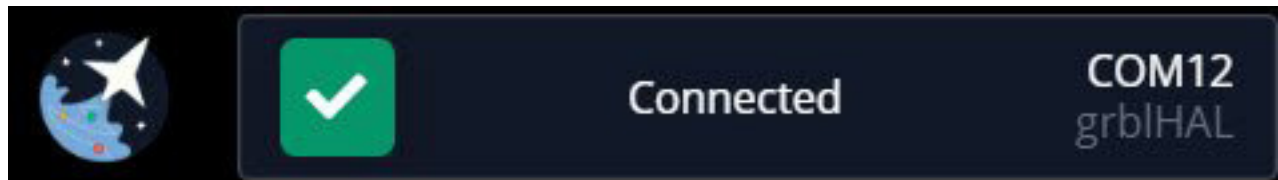

With "Connect to Machine" changed to "Connected", the plug icon turned green with a check mark, the status on the top right corner of the visualizer changed from "Disconnected" to "Idle", and the other controls that were greyed now being activated, it's time to take your CNC for a drive!

Quick Tests

Now that we have the basics plugged in and are connected in gSender, we're going to test out a couple things. This will help catch any issues before the SLB controller is more permanently mounted or you start on your wire management ;). Let's put this LongMill through some paces eh?!!

Power On Test

When the board is receiving power, you will see two specific green lights come on. One shows you that your 5V power is active, and the other shows that your 3.3V current is working.

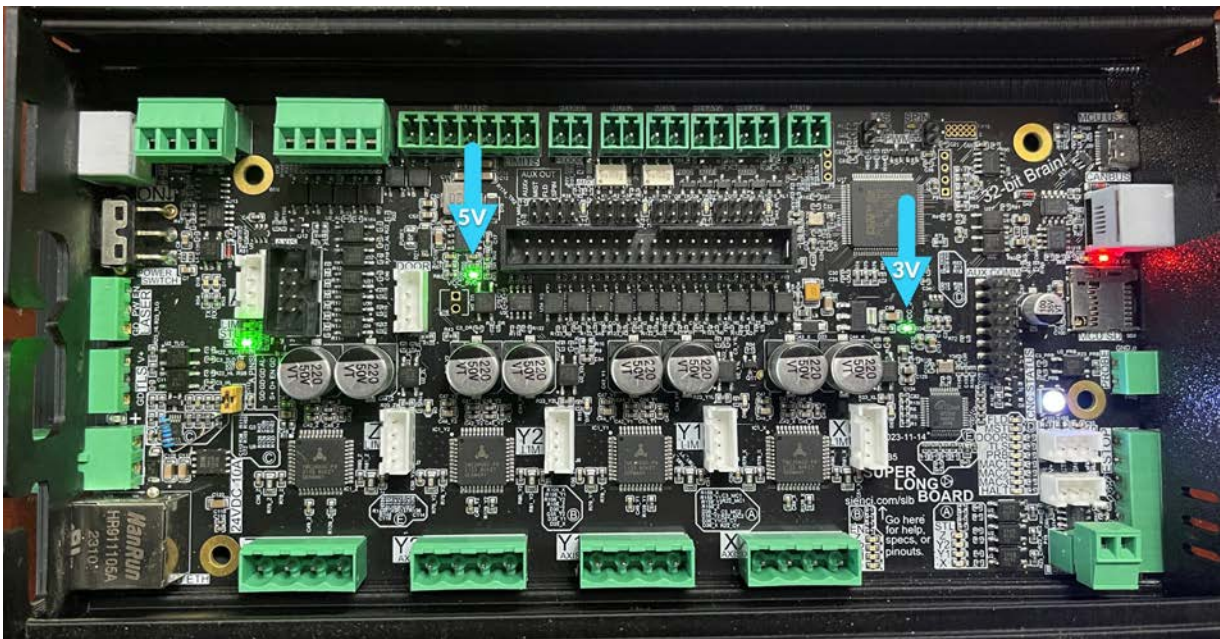

Now hit the E-stop button (it may already be pressed down). When you press it down, the E-stop button will go dark and power to the motors will be cut. You may see the light on the top of the button, or on the base of the E-stop.



The SLB will respond by turning several lights RED. Most notably your **CNC Status** light and a very small led called **HALT** will both turn red.

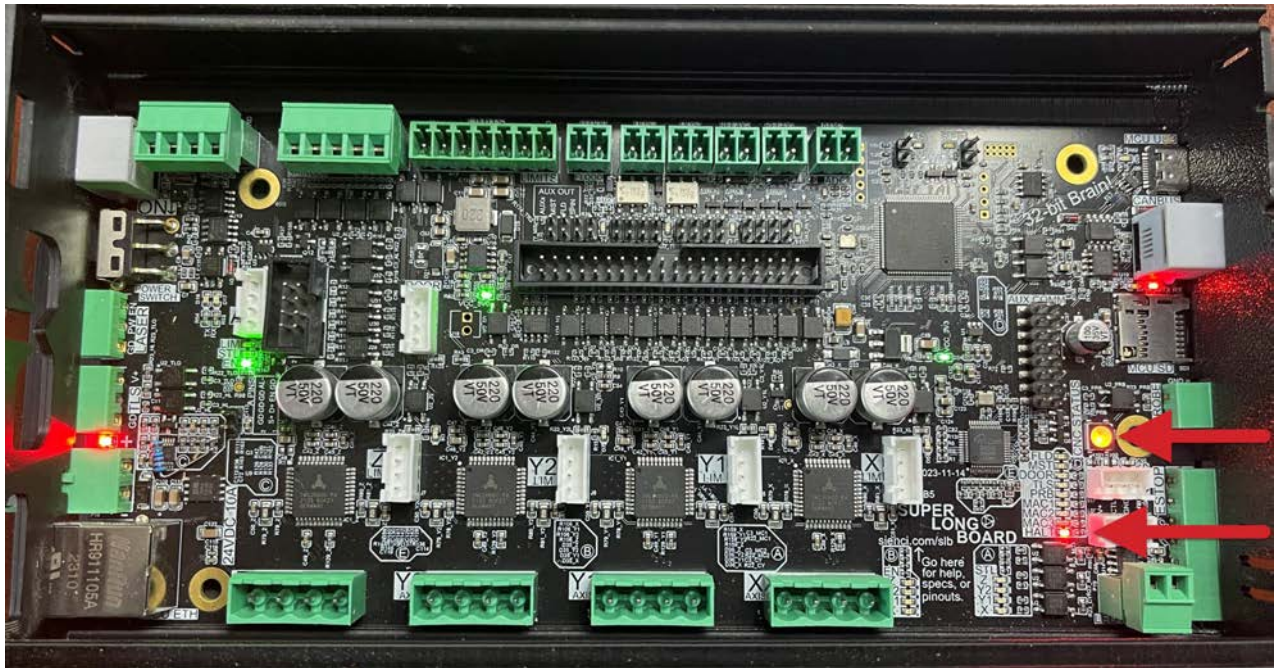

Now we can deactivate the E-stop button by turning it clockwise until it's raised again. You will see the E-stop button light come back on when raised correctly. We will need to unlock the SLB in gSender by pressing the Click to Unlock Machine button.

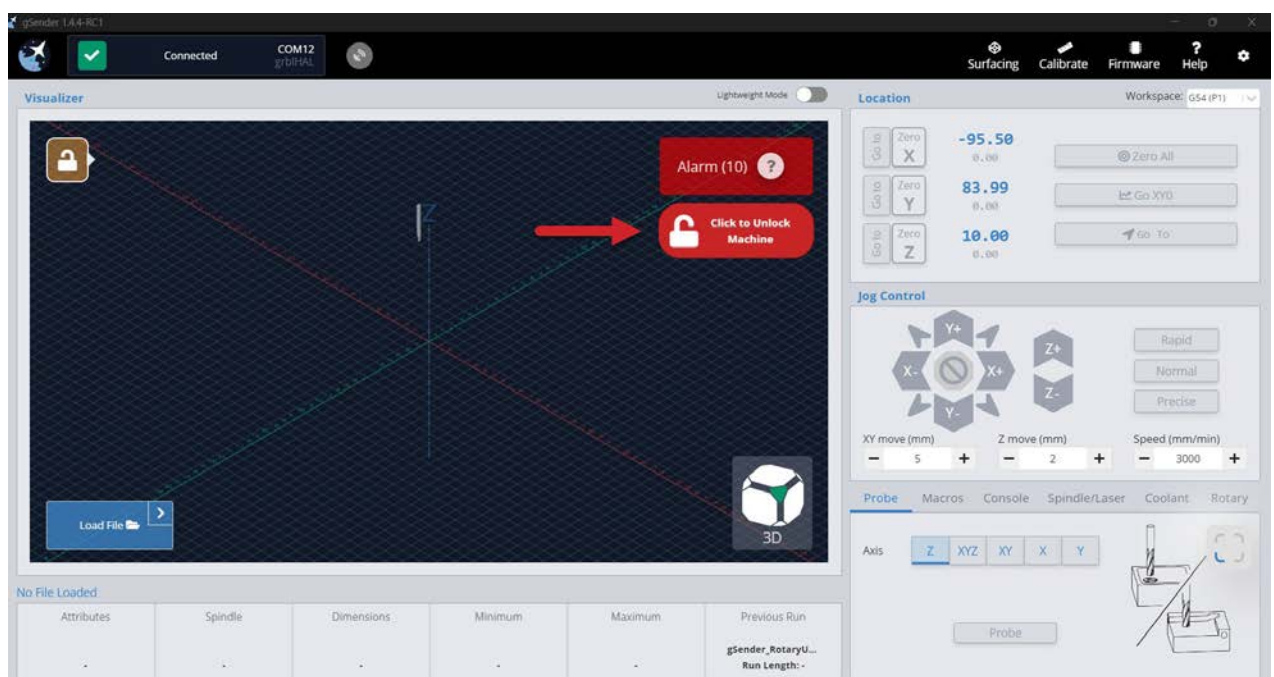

Congrats! You've completed the Power On Quick Test.

If your lights didn't come on or you experienced unusual behavior:

- Check that the power supply is plugged into the wall, the brick, and the board
- Ensure there is a light on the power supply (our new blue power supplies don't have one)
- Ensure the SLB power switch has been flipped to be 'ON'
- Ensure there are lights on the board

Move Test

Using the jog controls on the main page of gSender, try moving your machine around in the X, Y and Z-axes. Make sure they're going in the correct directions.

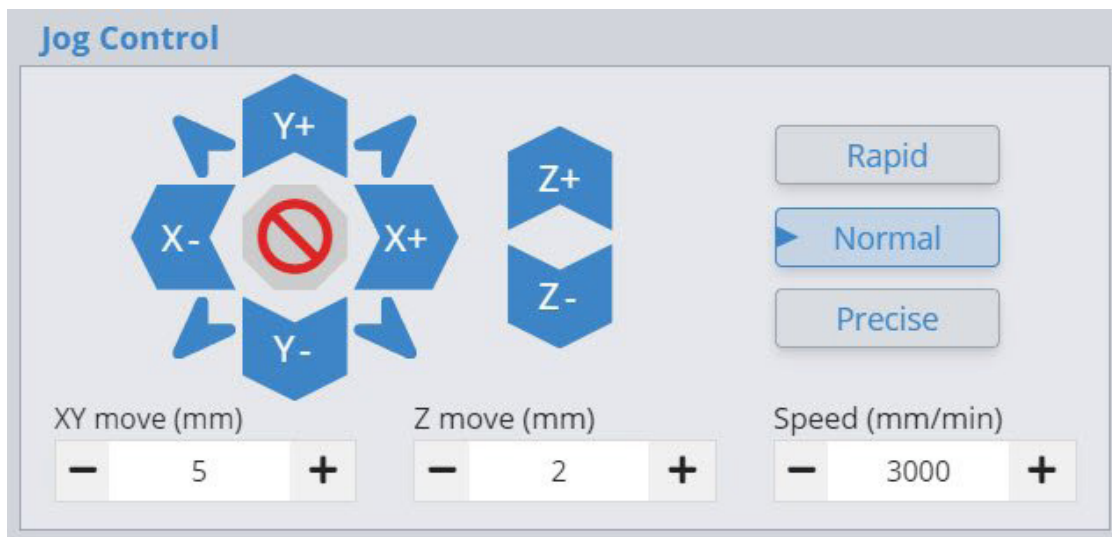

If you find that your axes are not moving in the correct direction, you can go into your firmware settings and change the axis that's wrong. Also, if you notice that your CNC reacts intermittently at higher speeds then you might have to either spend some more time tuning your machine's mechanics, or consider lowering the SLBs maximum speed with settings 110, 110, and 112.

Touch Plate Test

One last test is to check that your touch plate works. Navigate to the Probe tab and hit the 'Probe' button.

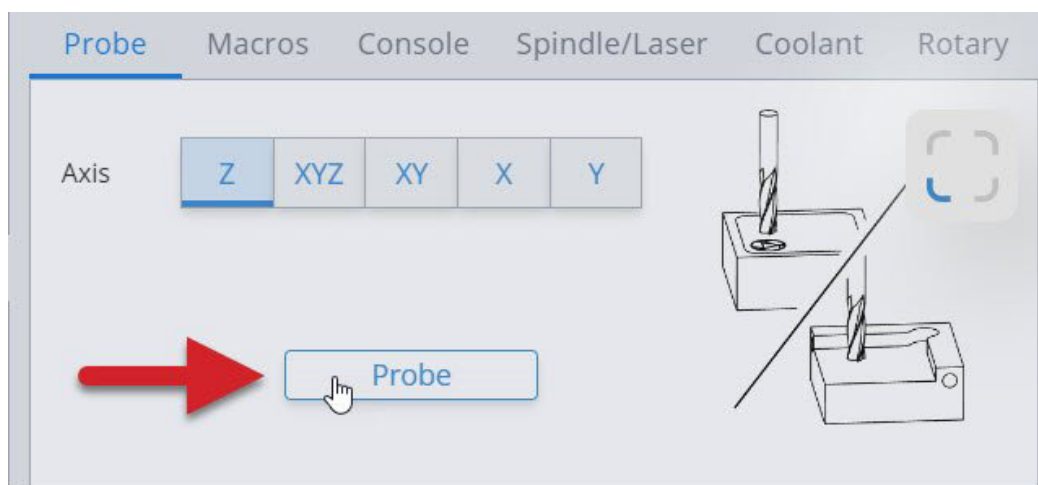

Then, tap the magnet to the touch plate. You will see the yellow PRB light on the SLB.

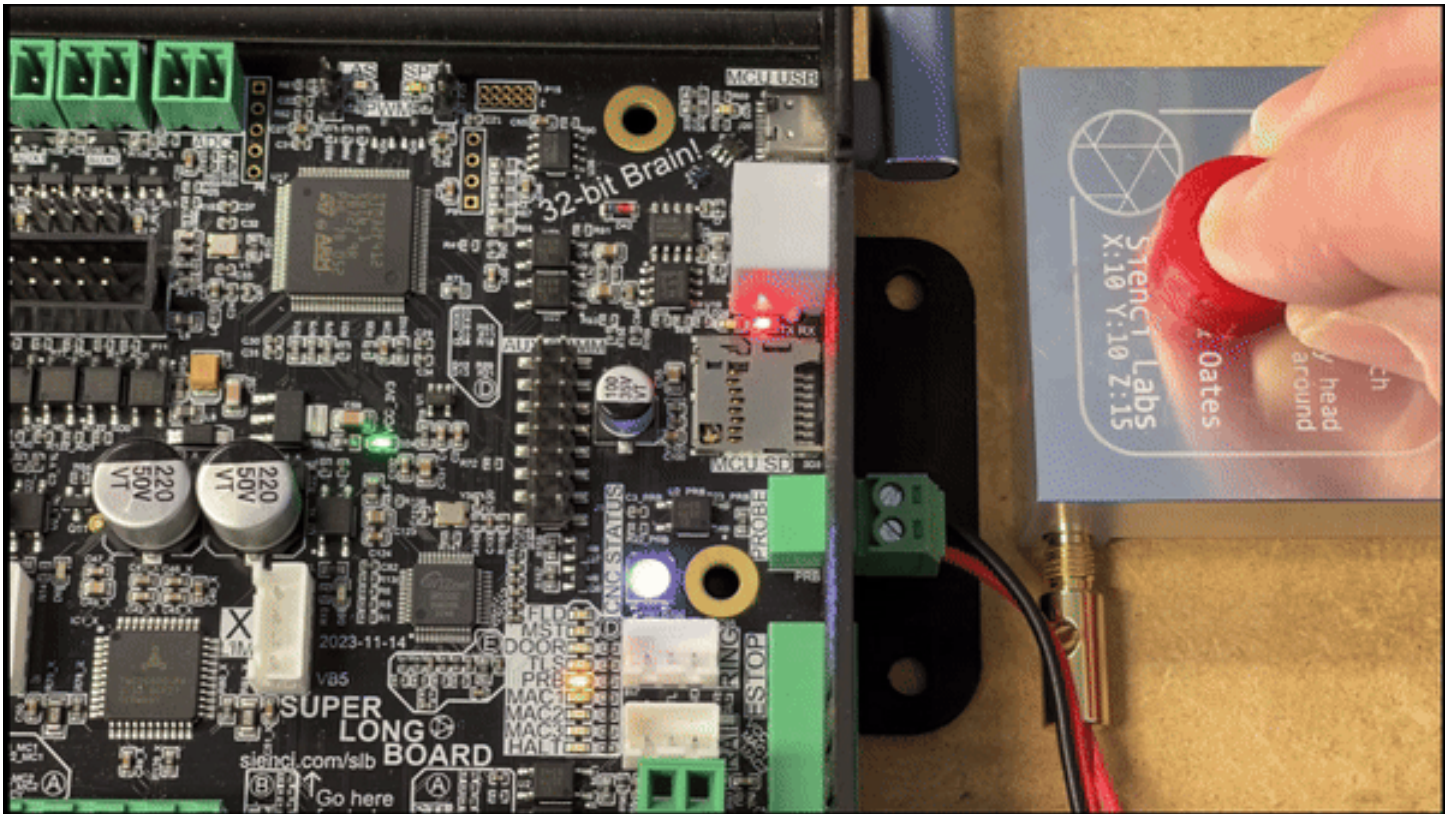

You'll know you are successful if the popup button turns blue, and says "Start Probe".

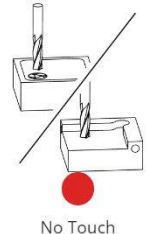
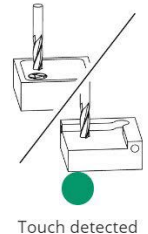
| | |
|---|--|
| <p>Probe - Z Touch</p> <p>Ensure tool is positioned as shown.</p> <p>To confirm a reliable circuit, touch your plate to the tool and look for the signal to be robustly detected (indicated by a green light) before returning the probe to the probing position.</p> <p>Probing cannot be run without confirming the circuit.</p> <p>Consider holding your touch plate in place during probing to get a more consistent measurement.</p> <p>Waiting on probe circuit confirmation...</p>  <p>No Touch</p> | <p>Probe - Z Touch</p> <p>Ensure tool is positioned as shown.</p> <p>To confirm a reliable circuit, touch your plate to the tool and look for the signal to be robustly detected (indicated by a green light) before returning the probe to the probing position.</p> <p>Probing cannot be run without confirming the circuit.</p> <p>Consider holding your touch plate in place during probing to get a more consistent measurement.</p> <p>Start Probe</p>  <p>Touch detected</p> |
|---|--|

If the light is coming on but the popup button isn't turning blue, this can sometimes be fixed by resetting your board settings. Do this by typing "\$RST=\$" into the console tab and hitting Enter, then use the power switch on the back of the board to "power-cycle" it off and back on again. Once you reconnect in gSender you can try probing again.

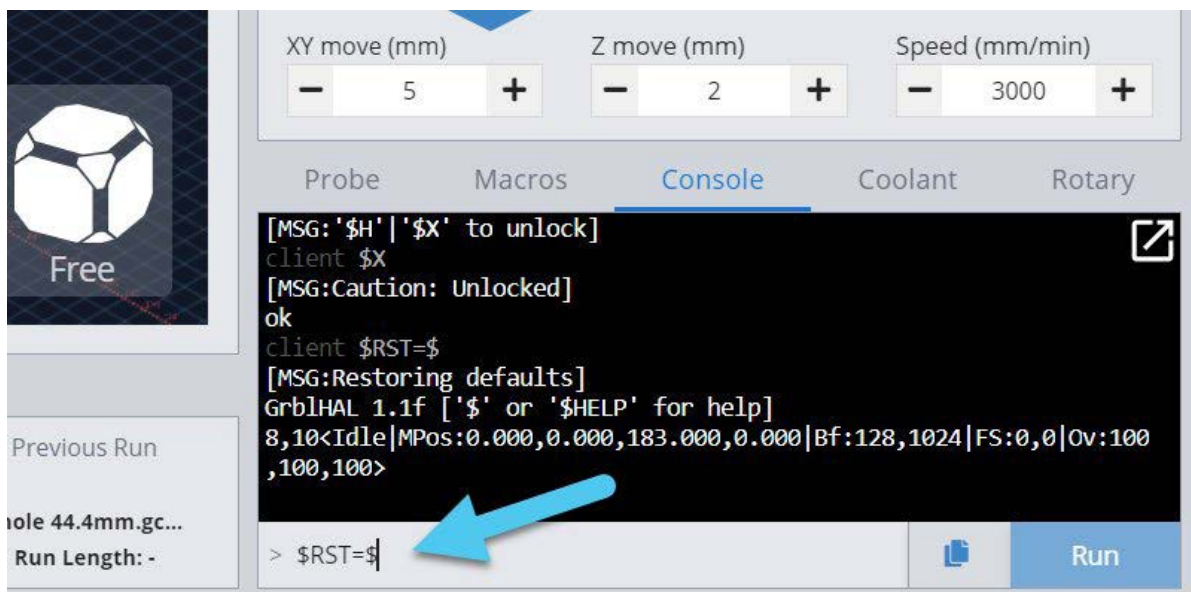

Congrats!

Your Quick tests are now complete. This means that all our basic accessories should now be set up and ready to use on your LongMill!

Things will still be a bit loose right now since we haven't yet tuned up the movement of the machine, but tuning will be the next step and knowing how to move the machine around will be important for when we mount it to a table. While we're here, take a moment to move each axis to each extreme while checking that the drag chains are reaching to all corners; especially for the y-axis. Don't be shy moving around, if you hear electronic music that's normal and if you hear a grinding noise when you hit the limits that's normal as well.

Tuning Movement

With the machine together and moving, it's time to tune its movement before we attach it to its work surface. Most of these tuning steps will be the same ones you'll use when performing maintenance on your machine.

Like other CNCs, and especially for hobby-grade machines, parts need to exist that can cancel out cutting inaccuracies by compensating for wear over time and the initial user assembly. For the LongMill these parts are the v-wheels, eccentric nuts, and the anti-backlash nuts. We chose these parts because they're commonly available and easy to use once you become familiar with them. Let's start with the v-wheels and eccentric nuts.

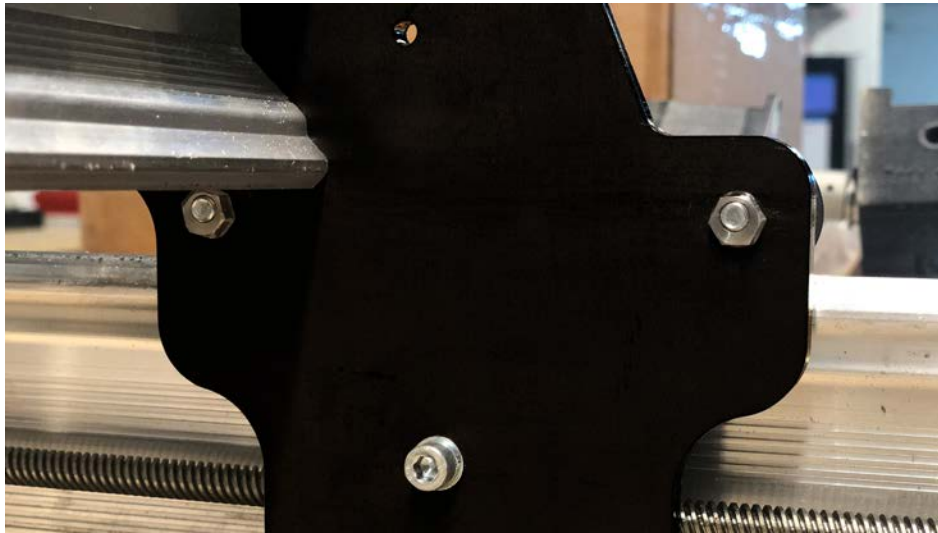

Recall that during assembly each steel gantry was fitted with one set of firmly bolted v-wheels and another set of loosely attached wheels with eccentric nuts, these loosely bolted ones are the ones we'll be returning to to finish tightening them up. For the Y-axis these are the top v-wheels (pictured) and for the X-axis these are the bottom. We'll work on these one plate at a time.

Eccentric nuts are 'eccentric' or 'off center' nuts and this means that by turning them you can change the gap between the v-wheels attached to them and the fixed v-wheels on the other side of the rail. We call this 'tensioning', a system where the wheels can clamp onto the rails enough to not move around loosely but still create smooth motion. You can see below what it looks like when an eccentric nut is all the way open (largest gap between wheels) and all the way closed (smallest gap between wheels) for both the Y and X-axes.

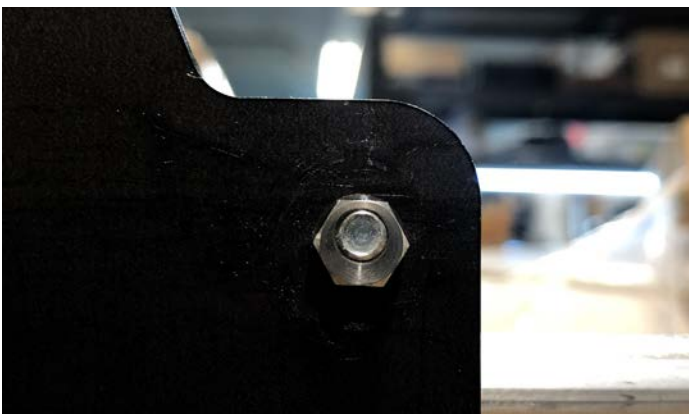

Y-gantry Open



Y-gantry Closed

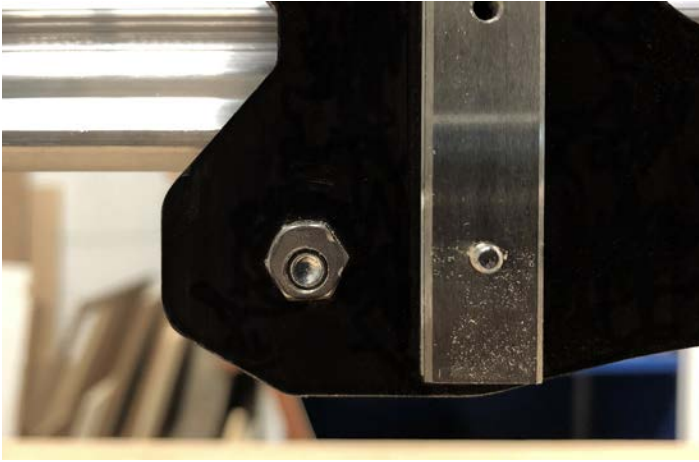

X-gantry Open

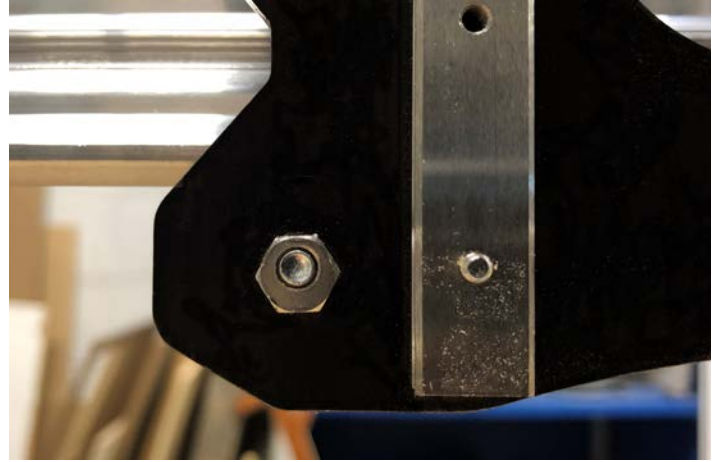

X-gantry Closed

To perform 'tensioning' the idea is to loosen the M5 bolt with an Allen key far enough that you can rotate the eccentric nut (picture 1) all the way 'open' as the starting point. Then, turn the nut whichever direction you choose to close it slightly (picture 2) and re-tighten the M5 bolt with the Allen key (picture 3). For the opposite Y-axis you can access the wheel bolts by lifting up the drag chain. At this point you'll want to check both the wheel you just tightened as well as its static wheel on the opposite side of the rail. Whichever wheel is on top will always be harder to spin, but ideal tensioning is when the lower wheel is able to barely turn when you use your fingers to rotate it.

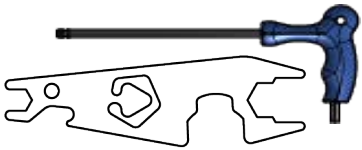

Use Wrench & M5 Allen Key

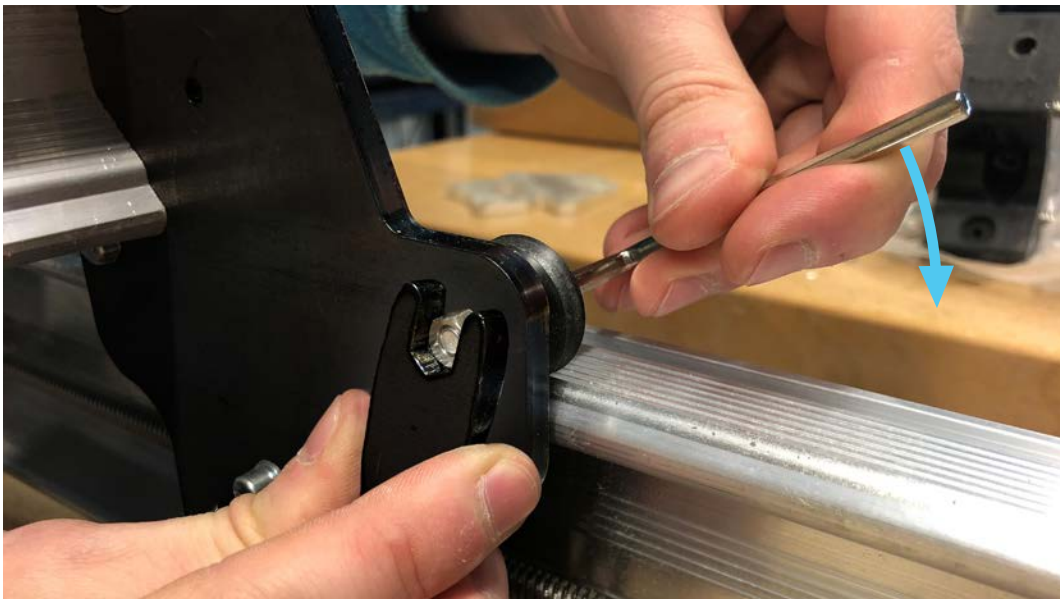

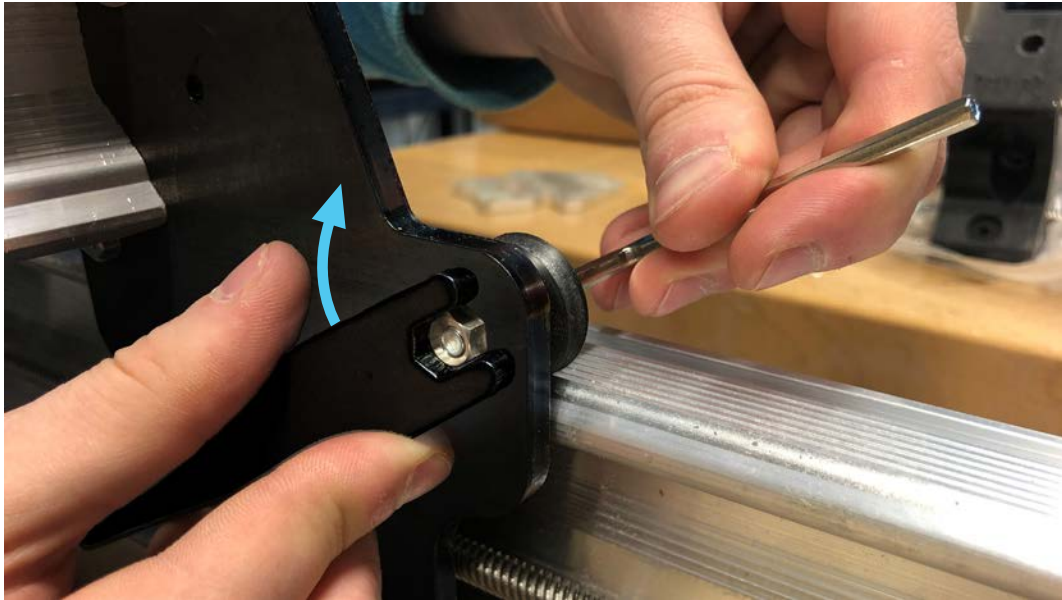

You'll likely need to repeat *loosening, turning the nut slightly, tightening, then checking the wheels* a couple times for each wheel pair until you reach the right clamping force. Take your time to slowly approach the right point rather than over-rotate the eccentric nut and put too much force on the wheels. Also, know that the wheels don't need to be 100% perfect to have a well-operating machine so if you feel like you've gotten close enough then feel free to move on to the next step. If you need more help visualizing how to do this you can watch our video: <https://www.youtube.com/watch?v=Z7WLMOk90V4>



Once you're done tensioning the wheels on all axes you should find that it's still easy to rotate each lead screw with your hands but if you grab the steel gantry it shouldn't move around on the rail. It might be a bit loose moving the plate back-and-forth and that's the next step when tuning.



With the v-wheels tightened down, go around and finish bolting down the remaining spring loaded anti-backlash nuts; there's one on each Y-axis and another on the X-axis. Recall the method for doing this when you did it for the Z-axis where you alternate making a couple turns onto one bolt and then the other until they're both tightened down fully. If you twist hard onto just one bolt while the other one is loose it can twist the anti-backlash nut and misalign it to the lead screw.

Lastly, let's check for backlash. The term 'backlash' refers to the difference between where the machine thinks it is and where it actually is due to components being worn out. Since your spring loaded anti-backlash nuts are brand new it's likely that they fit really well with the ACME lead screws, this means that trying to wiggle each plate along its rail should have no looseness.

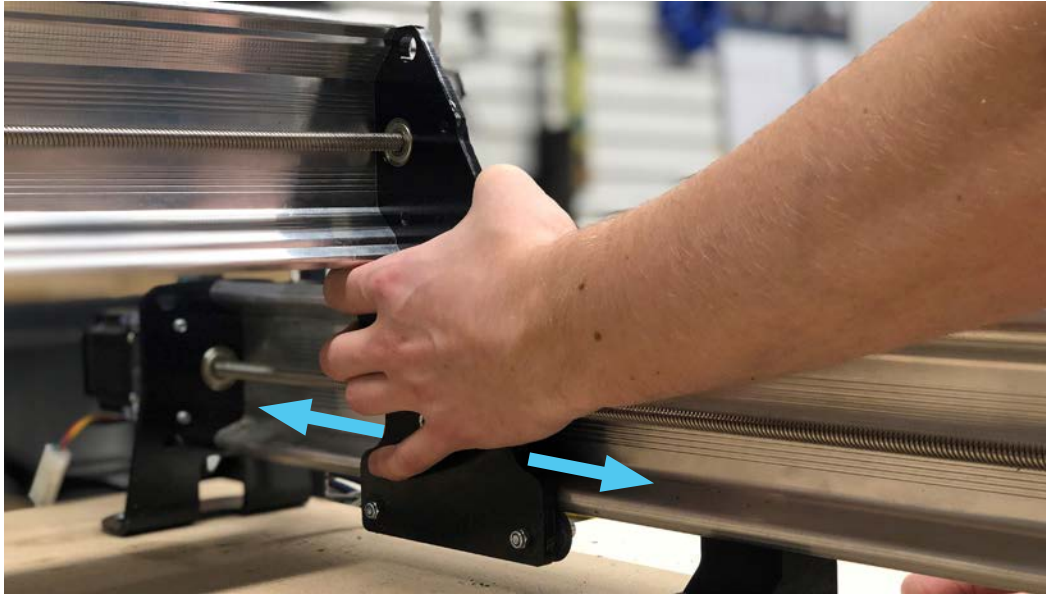

As you use your machine the nuts will wear out, but, thanks to the springs, they will self adjust and compensate for the backlash due to wear. This will keep your machine accurate for a long time. You may need to break them in a bit by moving back and forth on each axis at the beginning.

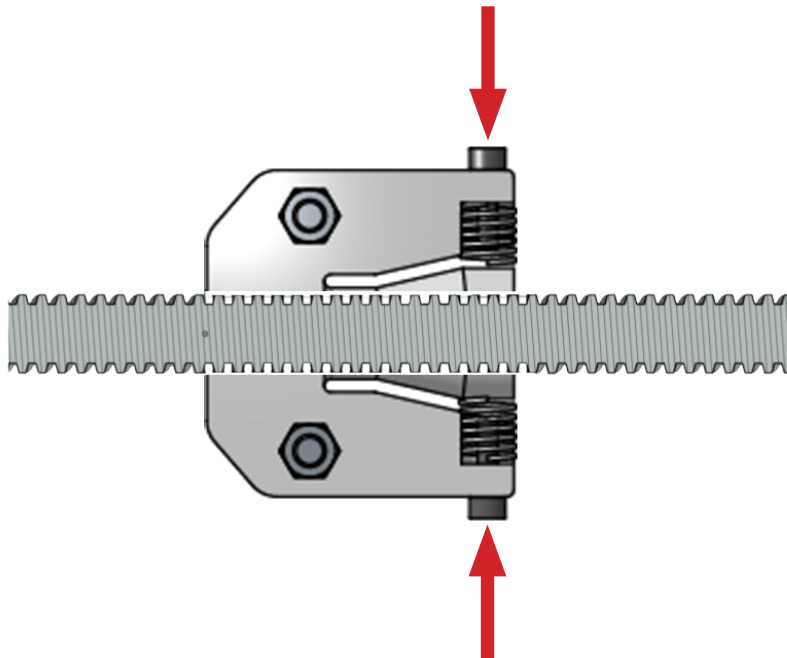

With all the tuning complete, we can move on to mounting your LongMill and starting to cut with it! If you're planning on using your machine for especially precise cutting, also consider checking out the 'movement tuning' feature built-in to the calibration section of gSender: <https://resources.sienici.com/view/gS-additional-features/#movement-tuning>

Part 6 Table Mounting

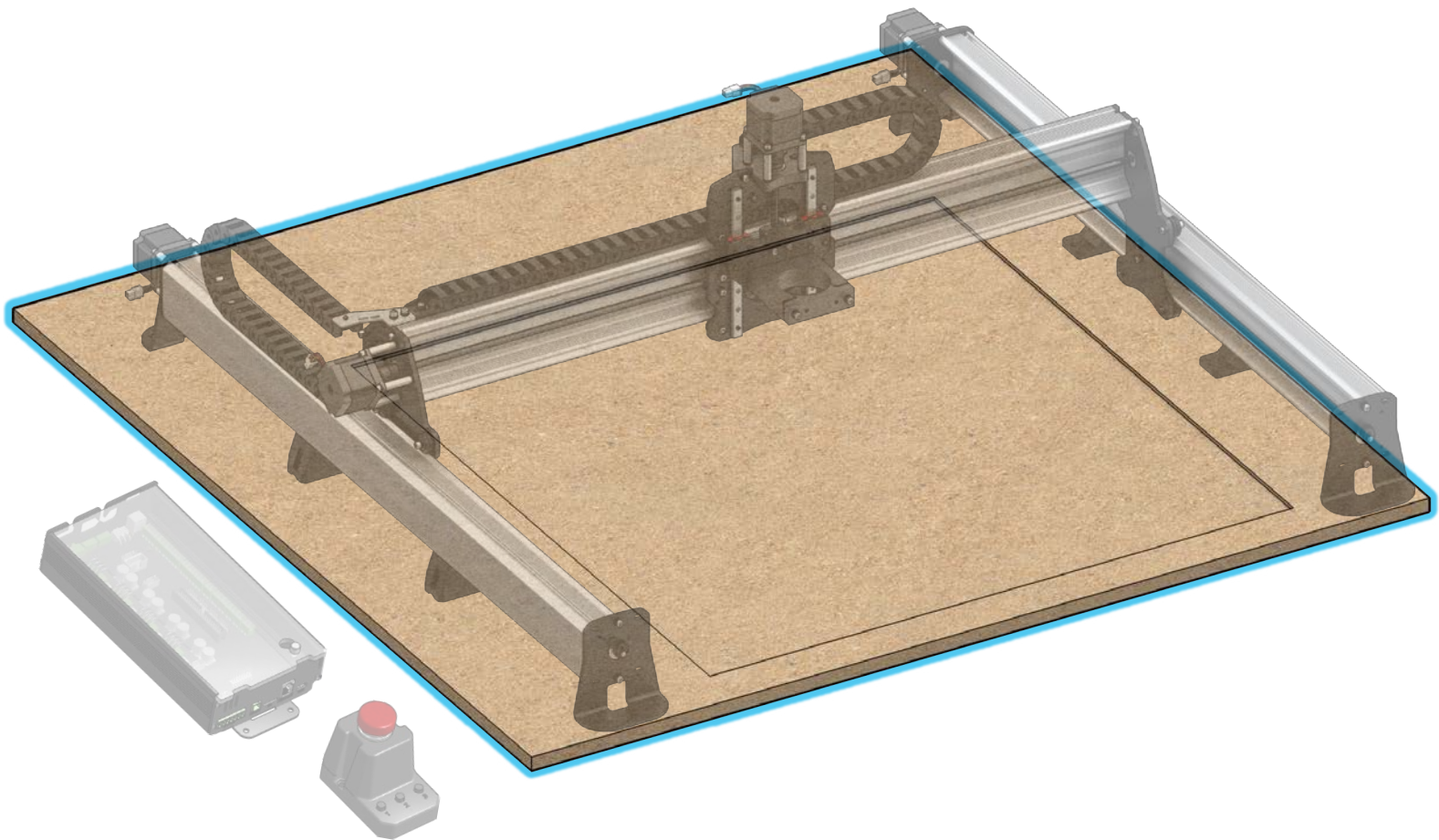

The LongMill is designed to be mounted to a flat surface which is provided by the user. This could be as simple as a single sheet of material, or as intricate as a multi-piece torsion table with t-tracks and threaded inserts. This helps to:

1. Save on the cost of shipping. For example, a 4'x4' piece of 3/4" MDF shipped often costs over a hundred dollars in shipping and is very easy to damage during transit. Instead, you can usually find a full 4'x8' sheet of 3/4" MDF for under \$60 at your local lumber or hardware store.
2. Give users flexibility to choose the size and material of the wasteboard to match their needs.

Suitable Wasteboard & Table

There are two factors to consider for your setup:

1. The table / mounting surface itself: this needs to be relatively flat to properly mount the machine to and it should be relatively sturdy as well
2. The wasteboard: this is the cutting area of the machine that you place material within and will get worn out over time. This will get flattened and occasionally re-flattened by your LongMill to ensure any material you cut is parallel to the machine. Ideally this should be removable. If you want to pass larger material through the cutting area you should also ensure the wasteboard is the same size as the machines cutting area otherwise it'll leave a lip when you flatten it out

The easiest setup that we recommend is a flat, clean piece of 3/4" MDF to act as both your mounting surface and your wasteboard, as shown at the start of this section. This is because 3/4" MDF is quite stiff and is readily accessible in 4'x4' and 4'x8' sizes from most big-box hardware stores or a lumber store. Any similar piece of thick, flat material would also suffice.

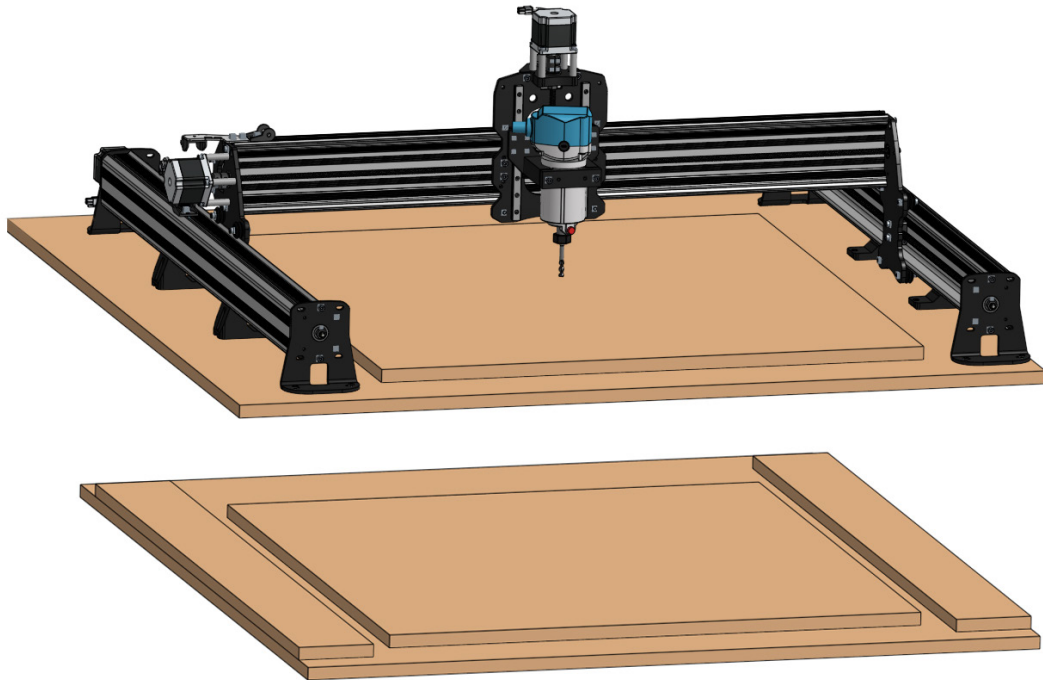

A higher-quality setup will have both a flat surface that your machine mounts to as well as a removable surface that you can cut away at to 're-flatten' after it starts to show some wear. You can see some examples of this above, one with a spare piece of MDF as the wasteboard and another with added 'foot risers' to maintain the LongMill's tall cutting height. These sorts of setups can sometimes be made out of a single sheet of 4'x8' MDF as shown below. Feel free to see more inspirational example setups by our community members here: <https://resources.sienzi.com/view/lmk2-table-enclosure/>

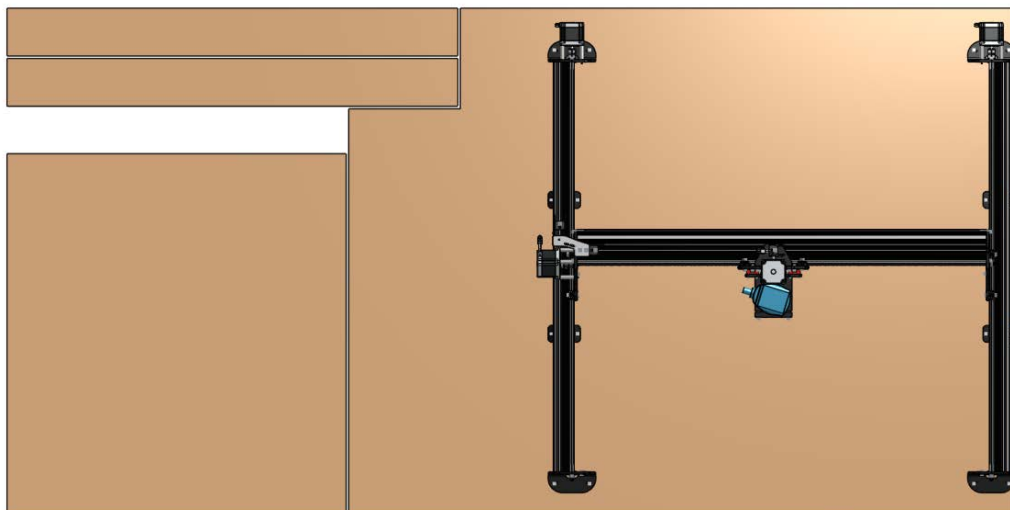

Machine Dimensions

LONGMILL 12x30 Configuration

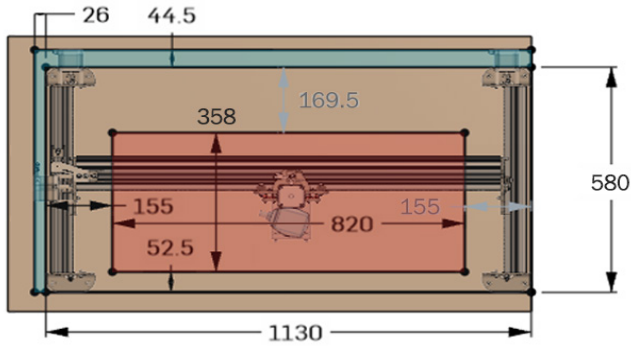

LONGMILL 30x30 Configuration

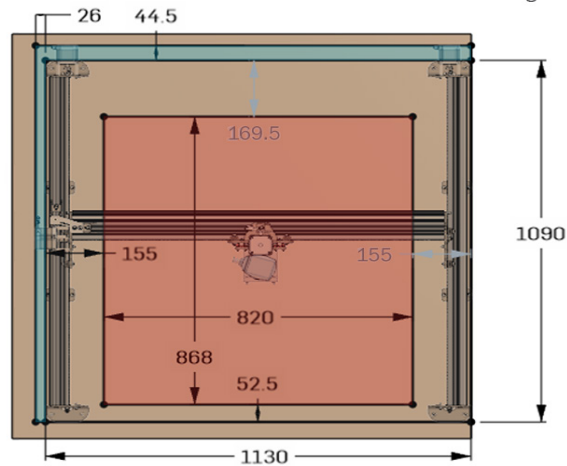

LONGMILL 48x30 Configuration

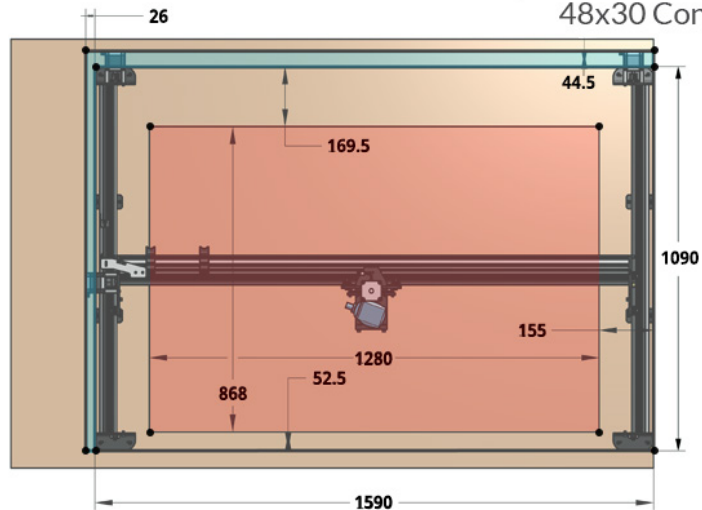

When getting ready to mount your LongMill the mounting surface will need to be at least the same size or larger than the space the feet take up, known as the 'foot base'. In addition, some parts of the machine extend outside the foot base like the stepper motors, so leave enough space around your mounting surface to account for this 'total machine outline'.

Each MK2.5 model (12x30, 30x30 and 48x30) is designed to generally fit on a 2'x4', 4'x4' and 4'x6' surface respectively. The diagrams above show a more detailed view for each model where the **red** represents the travel / cutting area and the **blue** shows the hanging features outside the foot base.

LONGMILL

Control Box

Size: ~ 210 x 100 x 20mm
(width x depth x height)

- I/O:
- Limit switches
 - Spindle or laser
 - Probing
 - Coolant/other 5v
 - Constant 12v
 - LED ring/strip
 - TLS
 - Ethernet/USB-C

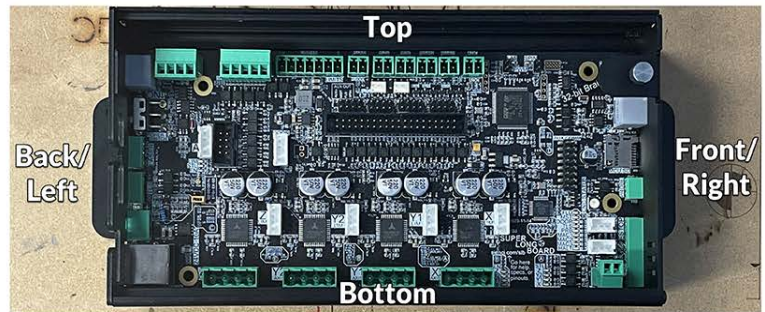

USB-C, E-stop & probe →



← Power Switch & ON/Off

The control box is also something you should plan for. It has the USB, E-stop and probe connections on the front side of the board, whereas the majority of cables come through the cable organization holes in the back of the board. When mounting the case, be aware of the length of your probe and E-stop cables and position them within easy reach.

Power is fed in through the back of the board, along with a power switch you can use to turn the board on/off. Normally the control box will plug in on the left side of the machine (unless you mirrored assembly to put it on the right side) and you can have it screwed into the table or fastened to the rail. (MK2 only)

Mounting your LongMill



Robertson driver used



There's a simple step-by-step process you can follow to ensure that your machine is mounted securely and accurately. Ensure your computer is connected to your machine so that you can move it around between steps. You can use the wood screws provided (#8 x 1"), or use your own mounting hardware depending on your setup. Either way, a drill with a long Robertson driver or a bit extender works best to reach all the holes when you begin screwing the feet into place.

Gently place your LongMill on the mounting surface roughly where you want it. Usually you'll want to have a reference 'straight edge' on the right and front of your surface to align the machine to; whatever best suits your setup. In this case we're using a 4'x4' MDF sheet as a combination mounting surface and wasteboard which we had cut to 42 inches to better fit in a car. We'll be mounting it in the middle offset from the factory edges and have the electronics box sit off to the side.

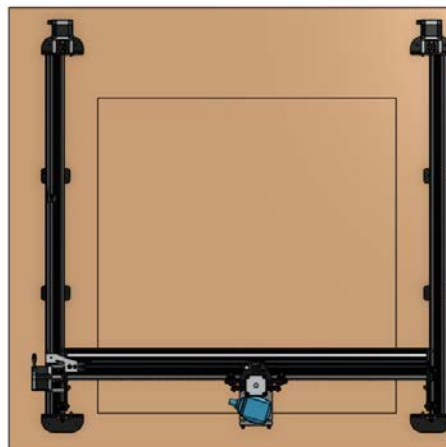

Start by moving the machine all the way to the front by jogging in the Y-axis on your control software. Keep moving forward until you hear a grinding coming from the motors on both sides to confirm that your machine is all the way forward on both sides. After this you can jog backward slightly.

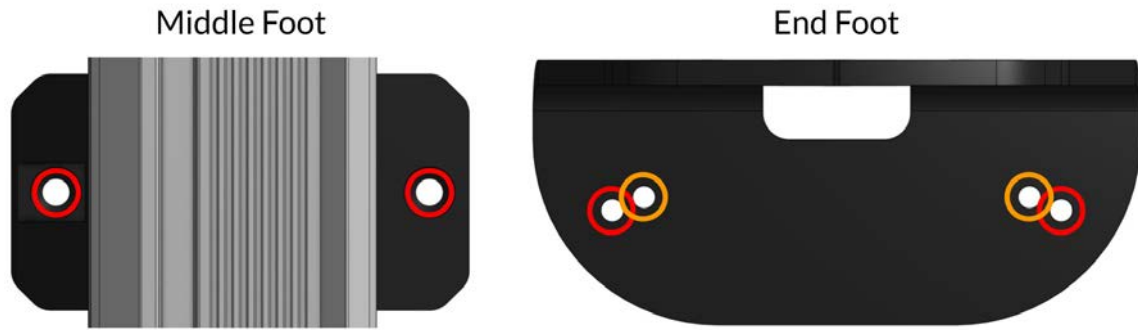

First we'll be mounting the whole right-side of the machine into place. Each foot has two primary holes for mounting (red circles) and the steel end feet have a backup set (orange circles) built-in to allow you to make adjustments in case you find that you made a mistake later on.

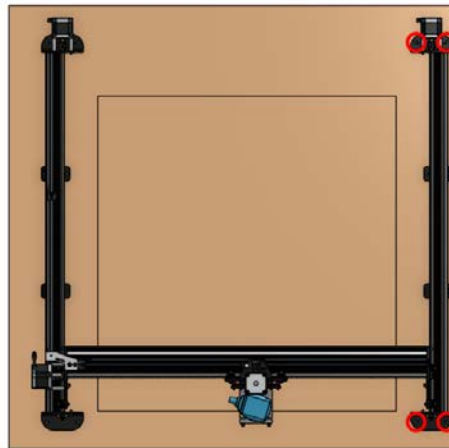

Start with the steel end feet using 2 screws per foot and ensuring they're aligned to where you want your machine to be. If you'd like to pre-drill the holes to avoid shifting around that's an option as well.

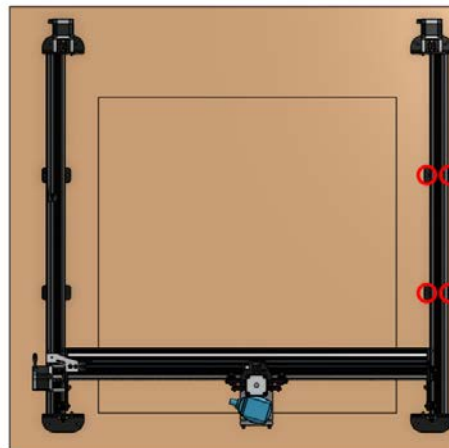

Next screw in the middle feet on the right side. Don't ream down as hard on the plastic feet as you did on the steel ones.

At this point the right side of your machine will be fully secure. When mounting the left side, we'll want to ensure it's mounted parallel to the right side and also that the back feet are aligned to each other. You can see in the diagram below why mounting the rails both parallel and in-line is important to ensure the CNC isn't overly stressed and also cuts how you expect it to.

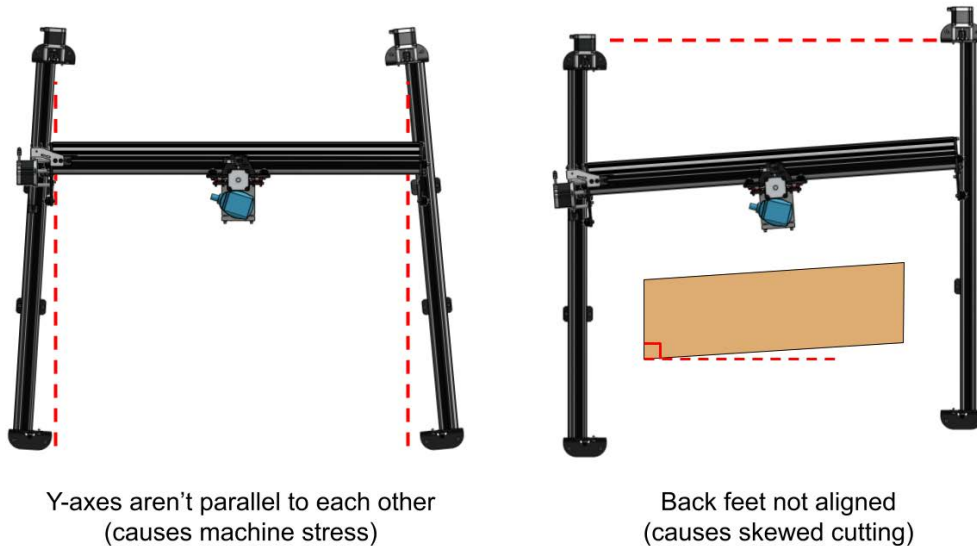

Checking for 'squareness' can happen many different ways depending on your tools at hand. For example, if your right side was attached 90° to your table front, then make another 90° mark for the left side to reference using a straight edge and a carpenter's square. If you have a friend to help you, the steel end feet also have a small notch built-in that can allow you to run a measuring tape under the X-rail from the top left to bottom right foot and top right to bottom left foot. Adjust the left side until these two measurements are equal and that'll ensure your machine is mounted square.

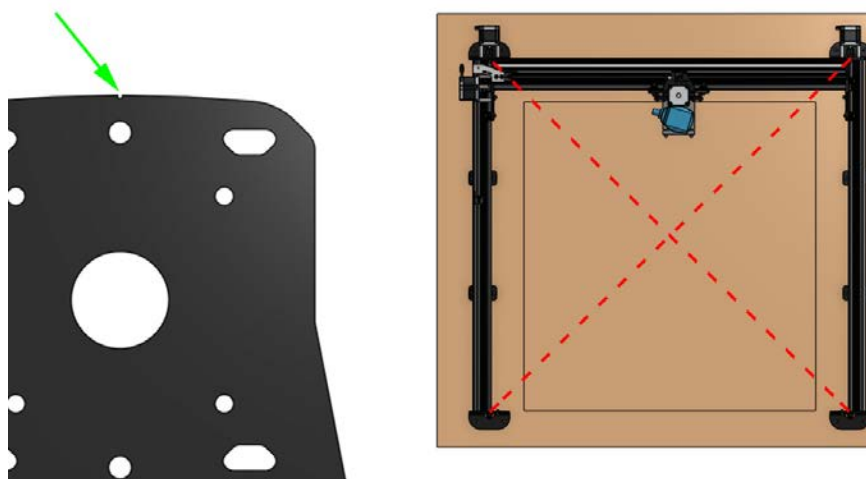

A third option is to use the 'XY Squaring' tool that's built into gSender. This tool is probably too fancy for most people but it's one of the most accurate ways to check the squaring on your machine. You can read how to use it here if you're interested and then come back to continue assembling once you're done: <https://resources.sienici.com/view/gS-additional-features/#xy-squaring>

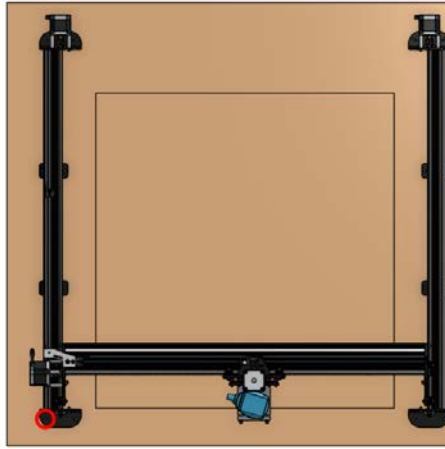

Once you feel confident in the foot placement, drive the first screw into place on the front left foot.

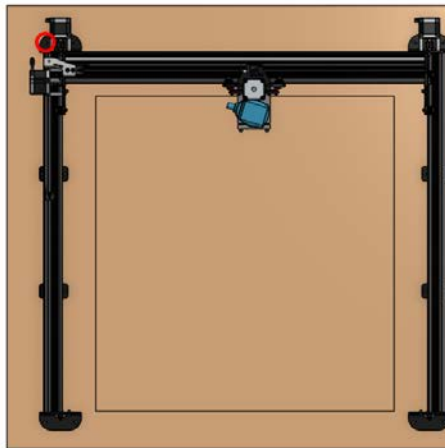

Then jog your machine to the rear and drive in another screw on the back left foot.

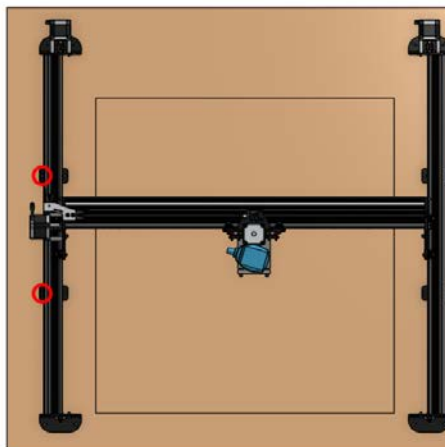

Now double-check that everything is looking correctly aligned before completing the mounting. At this point if there seems to be an issue don't sweat it, the second set of holes on the steel end feet will allow you to make small changes in how the machine is mounted. Once you're happy, jog the CNC roughly to the middle and finish securing the remaining foot holes.

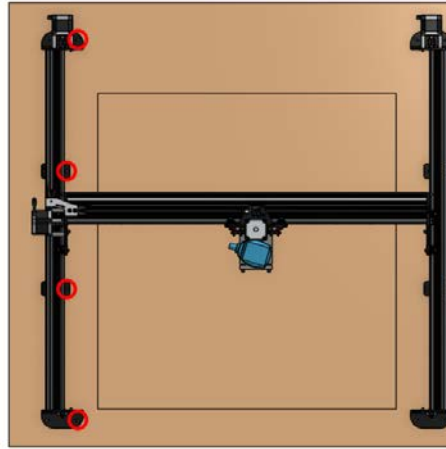

Followed by the second screw for each foot. Once complete, congrats! Your machine should now be fully secure and square to its mounting surface.

Mounting the Control box

You can mount your SLB however you like. Some factors to consider might be your machine setup, computer location, if you have an enclosure, or if you want to access other things or see the pretty lights on the board. The most versatile way is the 4 holes in the SLB's enclosure which will allow you to mount it to any flat surface, but we recommend that you mount it directly to your Y-axis rail. You will find your bracket and hardware in the SLB box.

Some of the extra tools you may need for this step:

- **Bolting to MK2 Rail** - M5 Allen wrench, bracket, 2 T-nuts and 2 M5 25mm bolts
- **Screw Down / Flat Mounting** - 2 to 4 wood screws (minimum size #4 or $\frac{3}{4}$ " and min length of $\frac{1}{2}$ ") plus the necessary screwdriver or bit driver

For rail mounting, slide the two T-nuts onto the track above the left Y-rail and loosely thread on the two M5 bolts. You may need to remove your limit switch on MK2's temporarily to enable the nuts to be slid into the rail.



Insert the sheet metal bracket into the slot at the back of the SLB enclosure. The bracket will feel loose for now so you'll want to hold it in place until the next step.

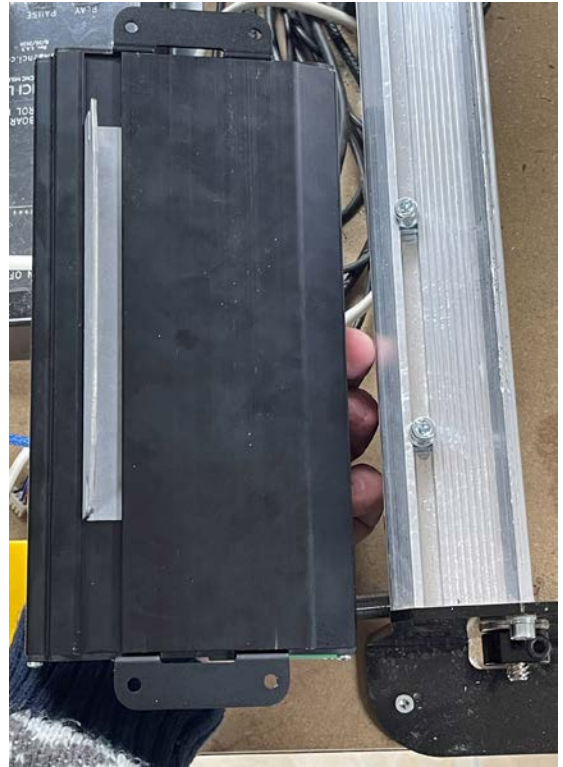

Place the bracket-enclosure assembly onto the Y-rail and slide the two screws into the slots in the bracket, then tighten the two screws with an Allen key to lock the entire assembly onto the rail.

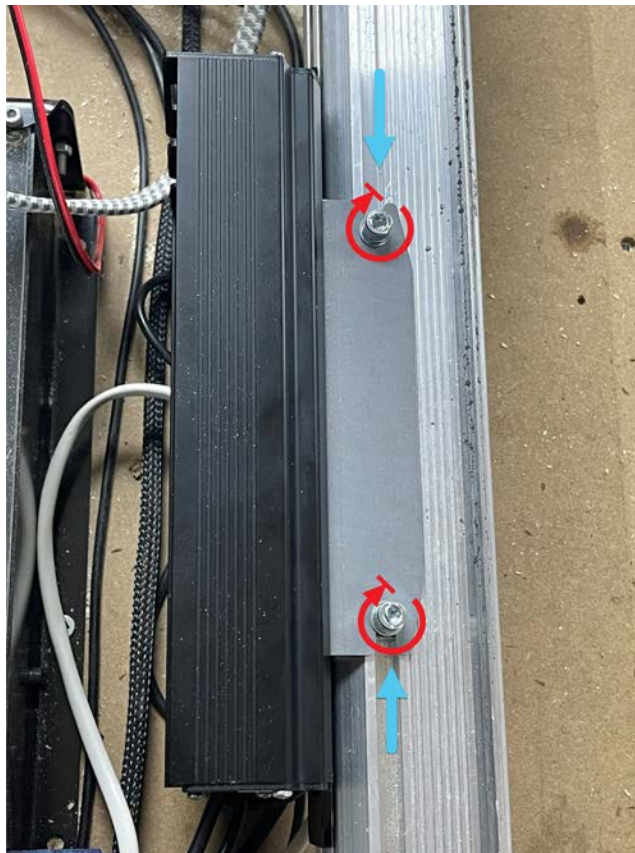

You can mount your SLB flat on your wasteboard next to your machine, or even on the side or at the back of your workstation. You can also hang the SLB vertically. The enclosure has been designed with reasonable consideration for dust penetration and vibration, but if you are a more cautious person you can feel free to mount the box further away from your CNC.

When placing your SLB on its own or among other CNC control electronics, consider that most wires are designed to route out the backside of the enclosure with the exception of a handful of more typically accessible plugs on its front like the E-stop and USB.

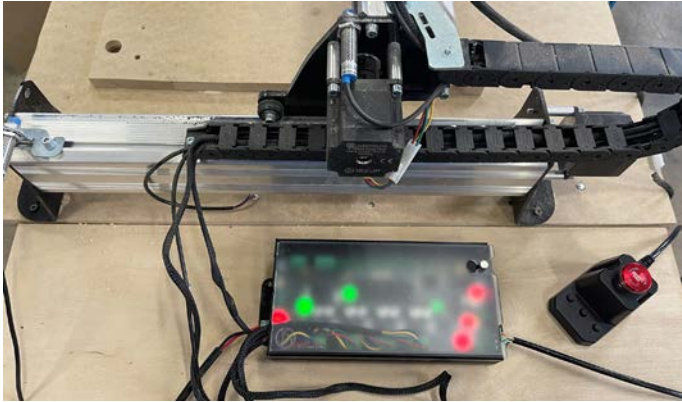

It's easy to use the enclosure as a template to mark and drill the holes. The holes are 4.5mm large, spaced 45mm from each other and 230mm from the opposite pair. They're not perfectly centered on the box but close to it.

You can use whatever bolt or screw type you like but the easiest approach is to use a minimum of 2 countersunk wood screws on diagonal holes from size #4-#8 and a minimum length of 1/2". You might have to remove some of the plugs on the ends to access the holes when you screw down the enclosure.

Mounting the Rest

With the machine mounted, take a once-over on the rest of your setup and see if there's anything else you'd like to fasten down before you start on your first project:

- 1. Power supply:** The body of the power supply comes with 4 mount points. Screw it down out of the way and be mindful that it gets a little hot to the touch while it's providing power to your machine.
- 2. E-stop:** the E-stop button is meant to be your 'oops button' so place it somewhere that will always be easy to access in an instant whenever something goes wrong. If you undo the 4 screws holding the E-stop body together you'll see that there are holes to attach wood screws through the black bottom so you can mount it to any surface and reassemble the E-stop once you're done. If you wish to place it further from the machine, extending it's wires is quite straightforward by unscrewing the green connector and either using a soldering iron or a crimpable wire extender to lengthen it out.
- 3. Motor cables:** an easy way to tidy up motor cables is to drill holes with a spade or forstner bit right where the cables dangle down at both the rear Y-axis motors and where the remaining wires come out of the drag chain. This will allow you to run the wires on the underside of your workspace.

Steps Forward



You're finished assembling your LongMill! Take a picture and pat yourself on the back for arriving here. So many people get LongMills from a variety of backgrounds so whether getting to this point took you an hour or a couple days we're sure your LongMill will be very happy with the new home you've given it.

1. The assembly manual concludes here but it's not over. In the next section (which continues on in our online resources), we've got a walkthrough put together to teach you the basics on using your new CNC and cutting out your first projects! (<https://resources.sienti.com/view/lmk2-first-project/>)
2. After completing this, we've also got a section on assembling any add-ons you might've purchased alongside your machine whether you've got the touch plate, dust shoe, t-tracks, limit switches, dust shields, laser, or others. (<https://resources.sienti.com/view/lmk2-add-ons/>)
3. Finally with the first project out of the way and all the remaining assembly complete you'll reach the LongMill **Handbook**. This section will become your bible on the LongMill, outlining all the daily operational details on how it runs, operation, feeds and speeds, maintenance, surfacing, project ideas and where to find them, troubleshooting, common CNC terms, and more. (<https://resources.sienti.com/view/lmk2-handbook/>)

You'll see all these sections and more in our website resources for the MK2.5. Feel free to have a look around and also check out our sections on 'CNC basics' or 'choosing software' if you still feel like you could use more information on those topics.

We really hope you enjoy using your LongMill Benchtop CNC in the days, weeks, and months to come. Remember that CNC routers are an amazing tool that you can use for whatever you like, and the point of the LongMill and it's community is to offer you resources and support so that you can be confident in using your CNC to make what you imagine. Good luck and happy making!

-The Sienti Labs team

LONGMILL

LongMill MK2.5 48" X-axis Assembly Manual 

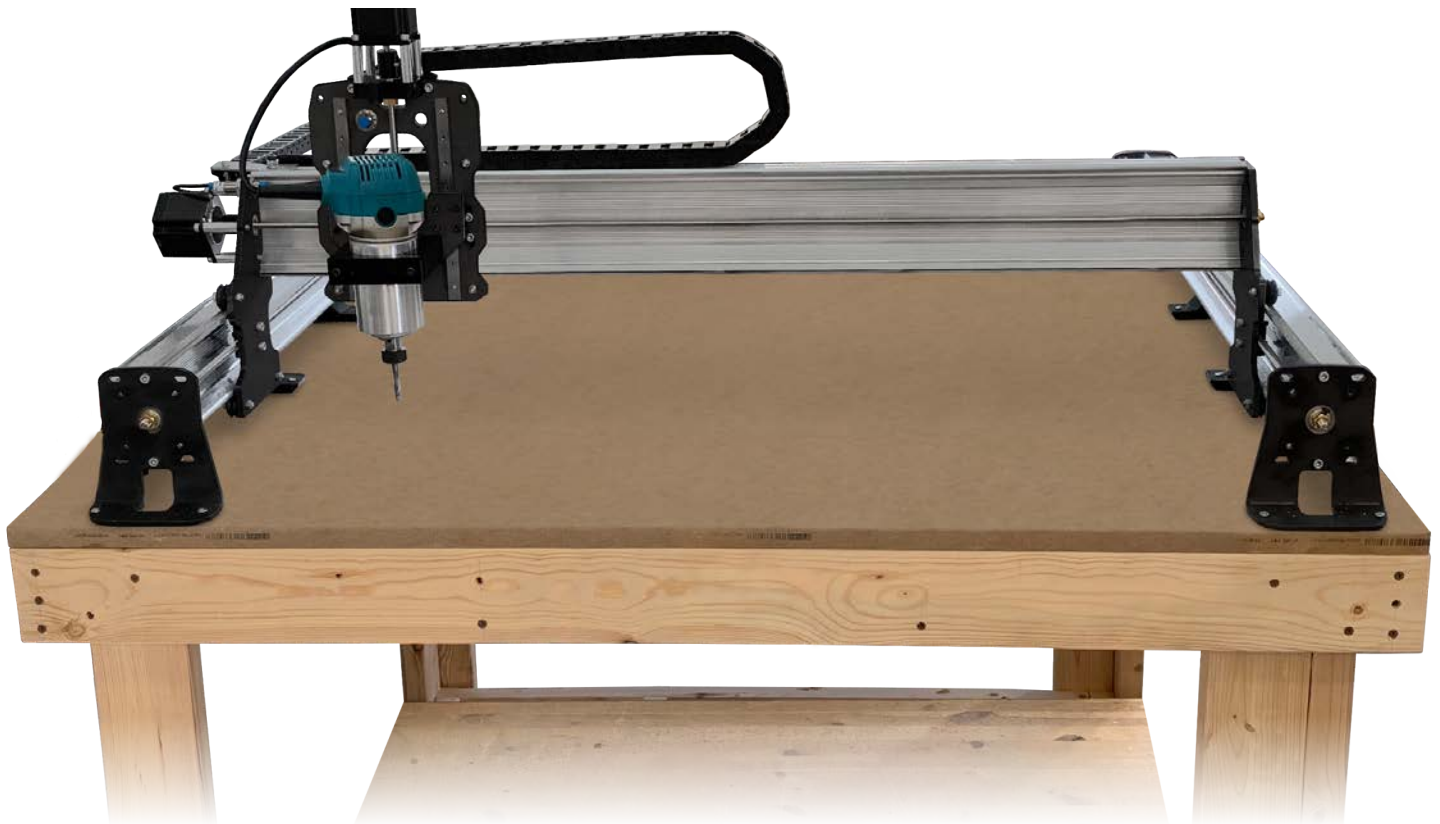

SIENCI LABS
IDEAS INTO REALITY

Table of Contents

| | | |
|-------------------|-------------------------------------|---------------|
| Section A: | What is this manual? | pg 96 |
| Section B: | 48" Rail box unpacking | pg 96 |
| Section C: | EX Delrin nut mounting | pg 98 |
| Section D: | EX Y-gantry assembly | pg 100 |
| Section E: | EX lead screw assembly | pg 102 |
| Section F: | Cable extension installation | pg 104 |

Section A - What is this manual?

This manual serves as a supplementary manual for any assembly steps that are specific to the 48x30 LongMill MK2.5. Whenever these 48x30-specific steps come along you'll see this symbol  in the main manual and some text that'll refer you to the alternate step you'll find here. There will also be a link to bring you to the alternate steps and another link at the end of those steps to bring you back to the main manual.

This manual is only needed for assembling the 48x30 MK2.5, so disregard it if you've got a 12x30 or 30x30 size.

If you'd like a printed copy of the entire assembly manual for the 48x30 LongMill, print this page to supplement the main assembly manual. If using a printed assembly manual, follow the name of the assembly step called in the main assembly manual and find that step on this page.

Section B - 48" Rail box unpacking

Inside the 48" X-axis rail box, you'll find the X-axis rail packaged with 5 boxes - three of which contain various hardware used throughout assembly, and two empty void boxes which serve to fill empty space inside the rail box and better protect the X-axis rail during shipping. These can be discarded.

You'll find the EX lead screw securely wrapped onto the X-axis rail. Unwrap this and set these both aside for the assembly of the X-axis.

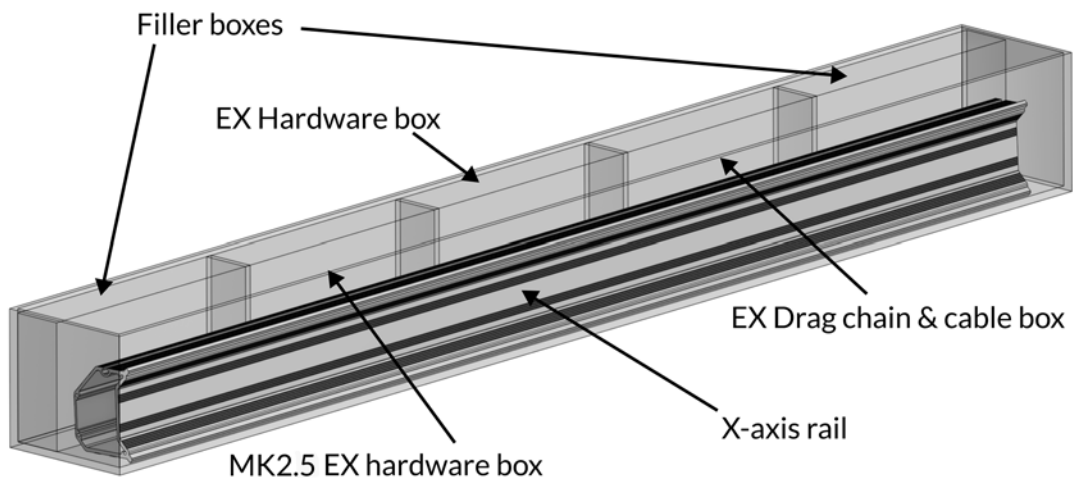

The 'EX hardware box' contains various hardware that is used when assembling the X-axis of your 48x30 machine, and the 'MK2.5 EX hardware box' contains other small parts specific to 48x30 MK2.5 LongMill. The 'EX Drag chain box & cable box' contains the longer 1400mm drag chain used on the X-axis, as well as some cable extensions. During sections of the assembly to follow, parts will be called from each of the boxes relevant to that section.



Continue to [page 4](#) in main LongMill MK2.5 assembly manual - **'Tools you'll need'**

Section C - EX Delrin nut mounting

Parts Needed:



M5 nylock nut

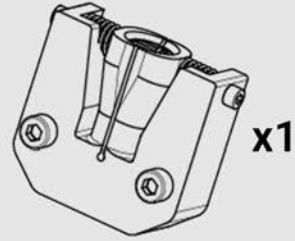

T12 Spring loaded anti-backlash nut

From within the EX hardware box, grab the much larger 'EX Delrin anti-backlash nut', as well as two 'M5-nylock nuts' from the green hardware bag. Just as the smaller spring-loaded anti-backlash nuts were assembled, this larger T12 nut will have two M5-nylock nuts fitted inside the two hexagonal pockets.



This T12 nut can now be installed onto the back of the X-gantry plate. Pass the two remaining M5-25mm bolts through the two outer holes in the X-gantry plate as shown threading into the T12 nut.



Tighten these bolts only until the spring lock washer has been flattened on the two M5-25mm bolts. These should only be snug as overtightening will not allow the T12 nut to self-align and may bind up later on.

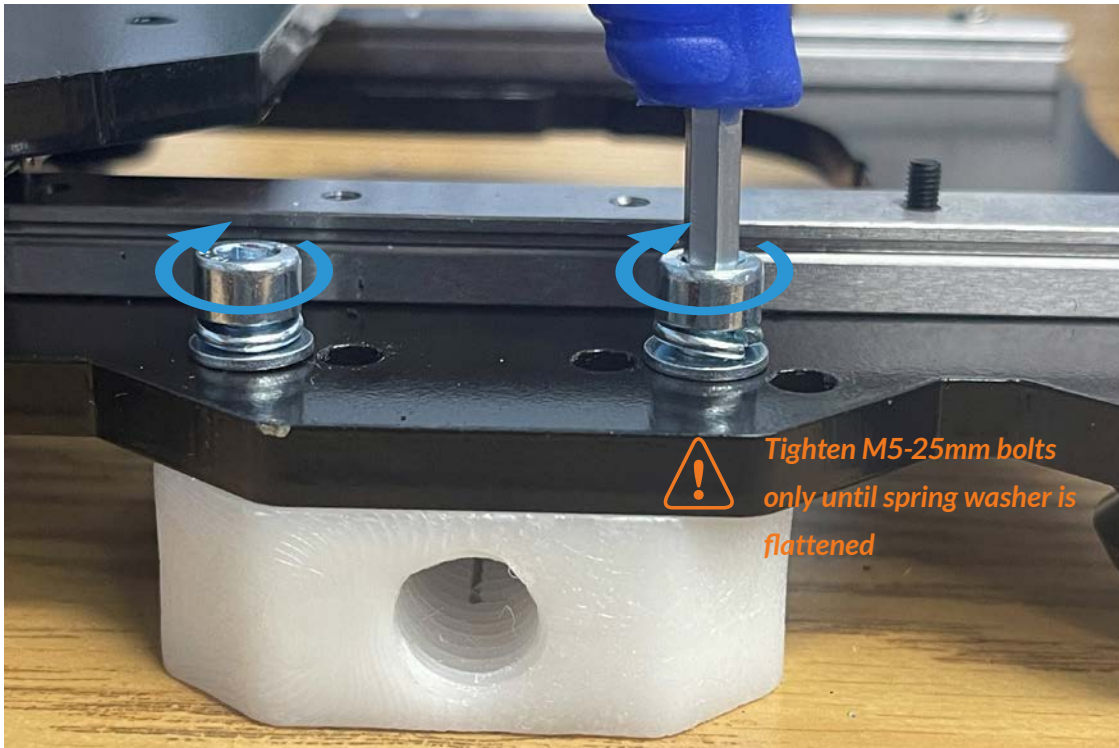

Continue to **page 19** in main LongMill MK2.5 assembly manual - [‘Connecting the sub-assemblies’](#)

Section D - EX Y-gantry assembly

Parts Needed:

Previously Assembled

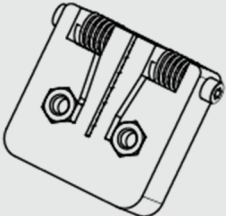

x2

T8 Spring loaded anti-backlash nut

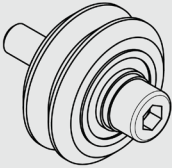

x4

V-wheel assembly



x4

Eccentric nut



x4

M5-25mm bolt

The Y-gantry plates will have two sets of holes used for installing the upper V-wheels assemblies. For the LongMill MK2.5 48x30, loosely install the upper V-wheel assemblies into the top two holes using eccentric nuts as shown below. Orient the inner holes of the eccentric nuts away from the bottom edge of the gantry as shown.

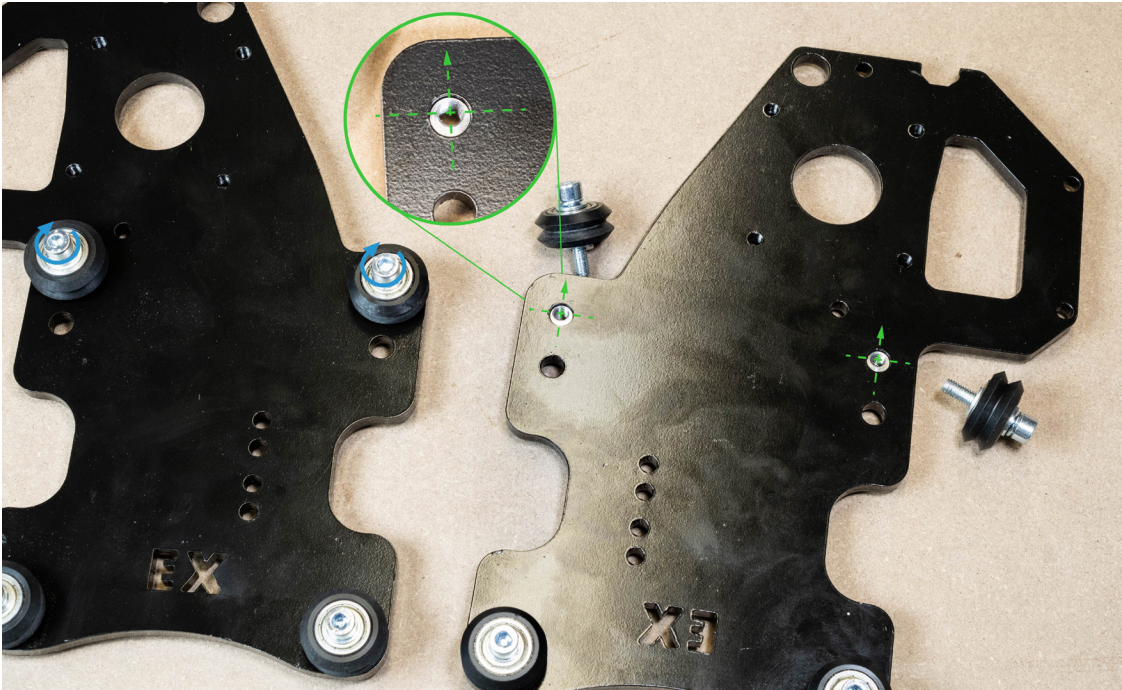



Each of these Y-gantry plates will also have two sets of holes used for mounting a T8 anti-backlash nut. Using the highlighted holes on each Y-gantry plate, attach each T8 nut to the back of each Y-gantry plate using two M5-25mm bolts.



Continue to [page 26](#) in main LongMill MK2.5 assembly manual - 'Y-axis middle feet'

Section E - EX Lead screw assembly

X-axis motor mounting

Parts Needed:

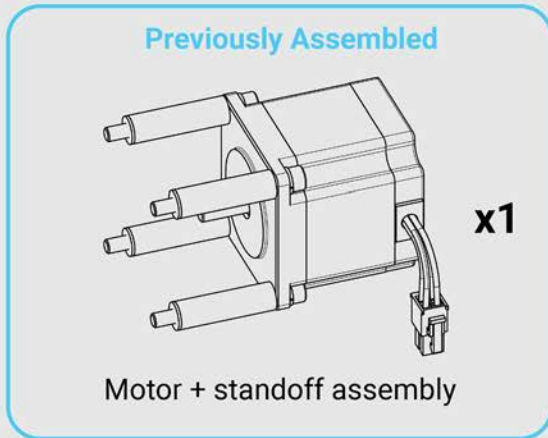

EX flange bearing

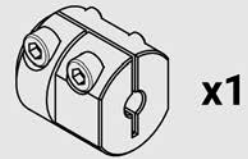

EX coupler

Grab a larger EX flange bearing and EX coupler from the EX hardware box, as well as one pre-assembled motor + standoff assembly.

Slide the EX flange bearing into the left Y-gantry plate.

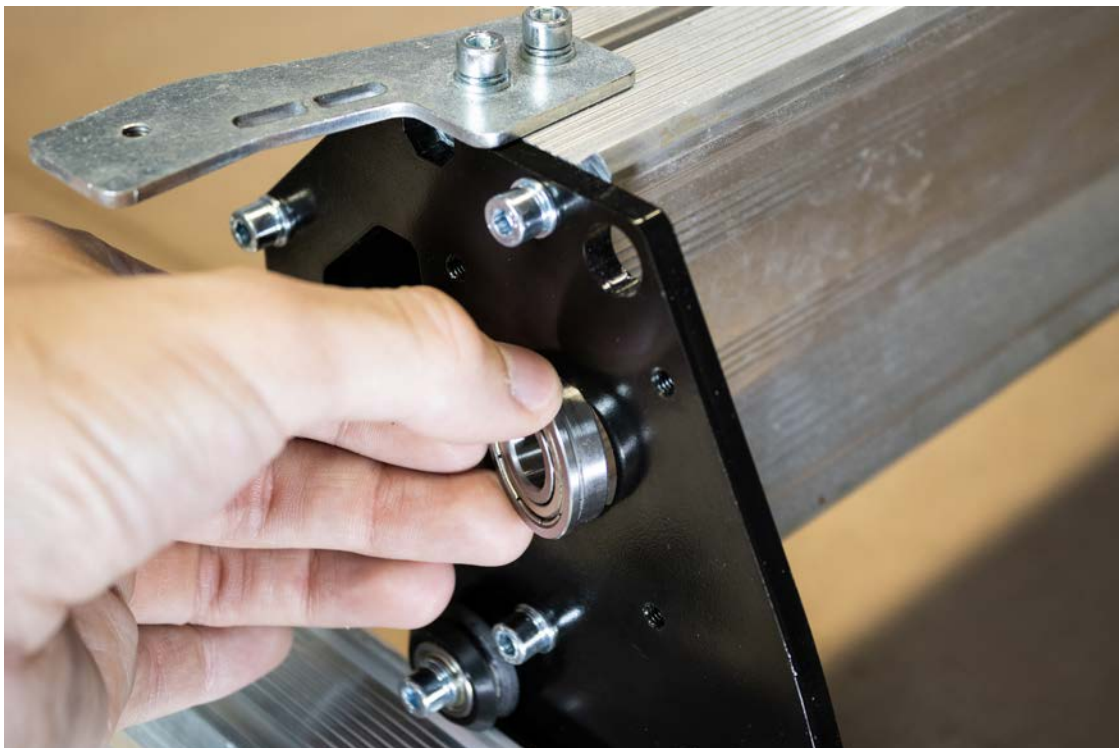

Slide the EX coupler over the motor shaft. Do not tighten the bolts on the coupler, this will be left loose until the lead screw is installed.



Mount this assembly onto the left Y-gantry plate, keeping the flange bearing in place. Orient the motor so the wires are facing towards the rear of the machine.

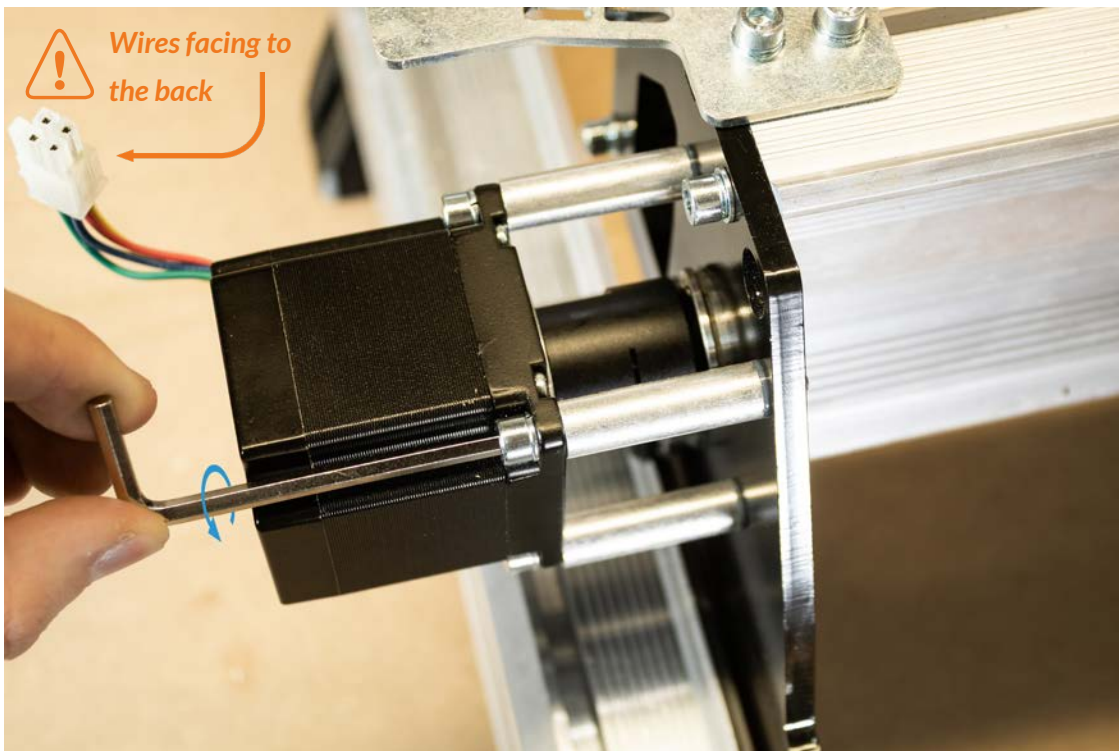

X-axis lead screw installation

Parts Needed:



x1

EX lead screw



x1

EX flange bearing

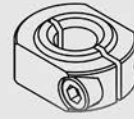

x1

T8 Clamping Nut



x1

M5-16mm bolt

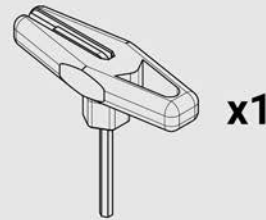

x1

Allen key + handle

From the EX hardware box, grab the longer EX lead screw, as well as the second EX flange bearing, T8 Clamping nut with M5-16mm bolt, and Allen key + standoff assembly.

Pass the EX lead screw through the right Y-gantry plate towards the XZ-gantry assembly. Be careful not to bend the lead screw while doing this or handling it otherwise.

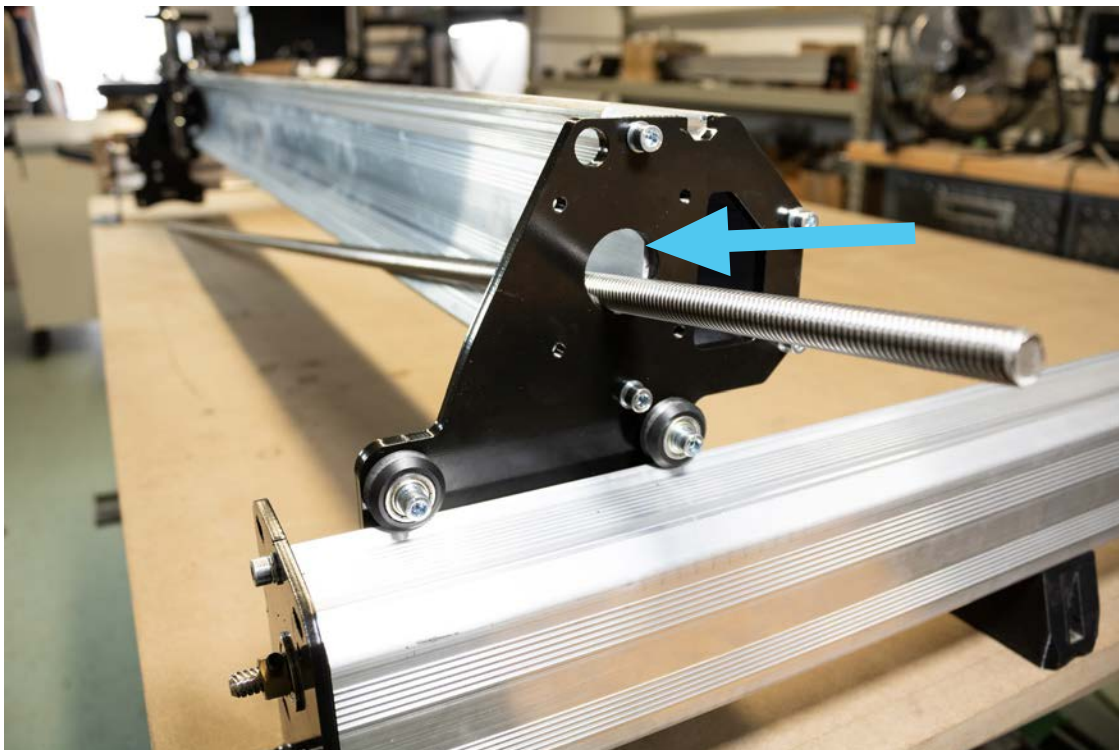

Begin threading the lead screw into the X-axis T12 anti-backlash nut.

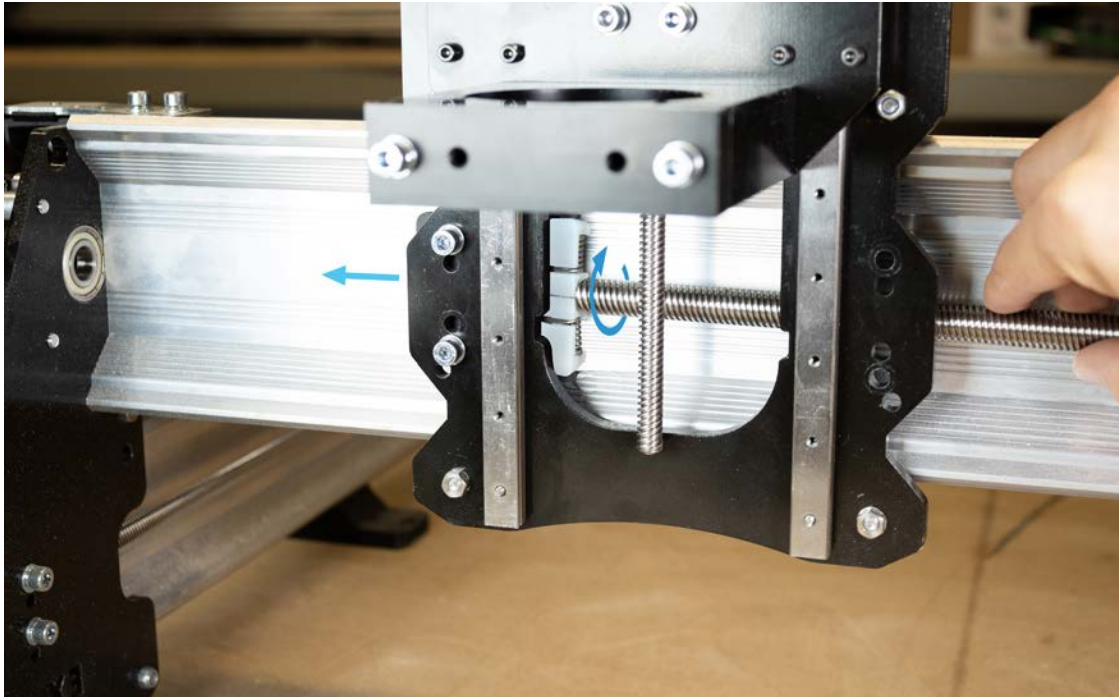

Continue threading the lead screw until it sticks out from the left side of the X-axis gantry. Slide the lead screw and X-axis gantry towards the left and pass the end of the lead screw into the flange bearing and into the motor coupler.

Push the coupler towards the right, and the X-gantry towards the left to ensure the lead screw is seated properly inside the coupler.

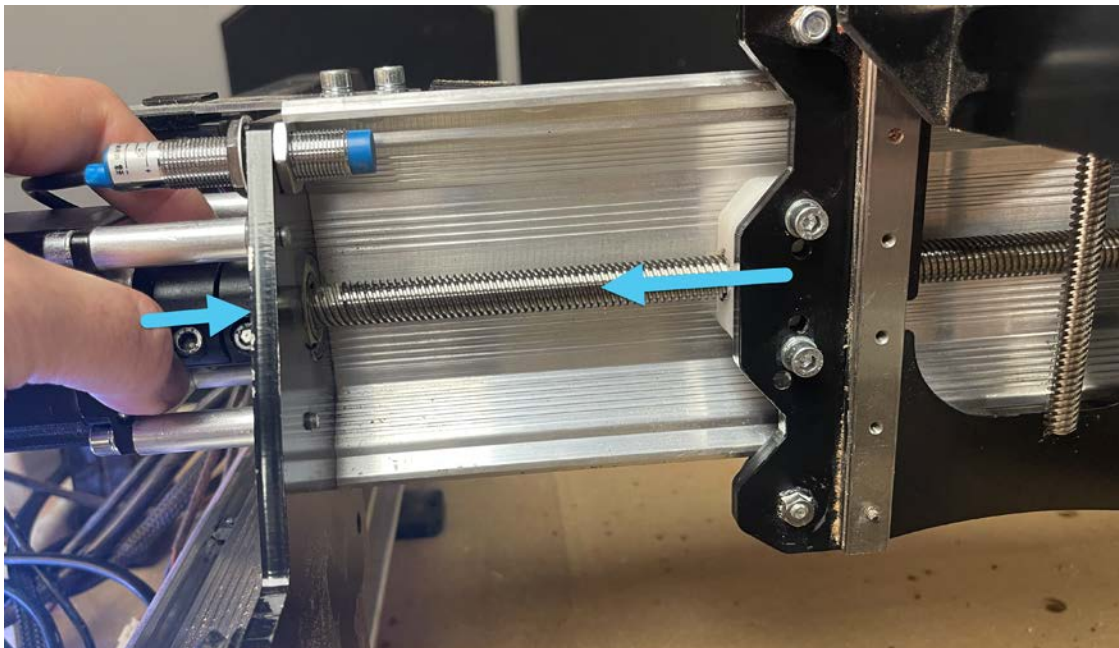

Tighten the motor coupler onto the lead screw. Use the allen key & handle to do this as this bolt must be very tight.

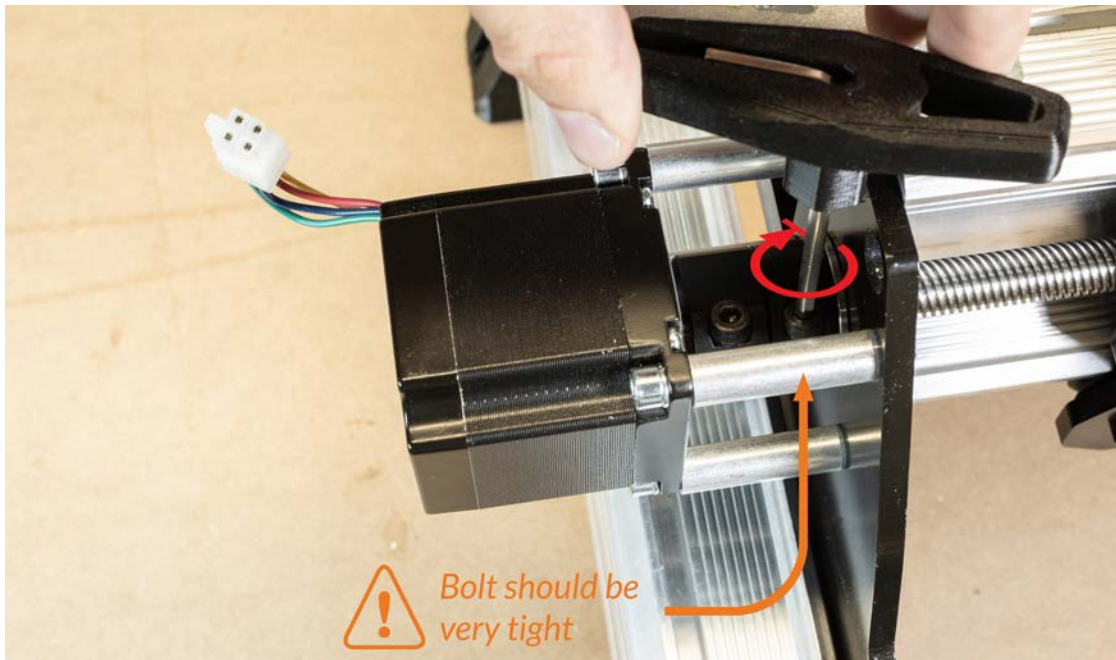

Remove the bolt from the other end of the coupler completely.

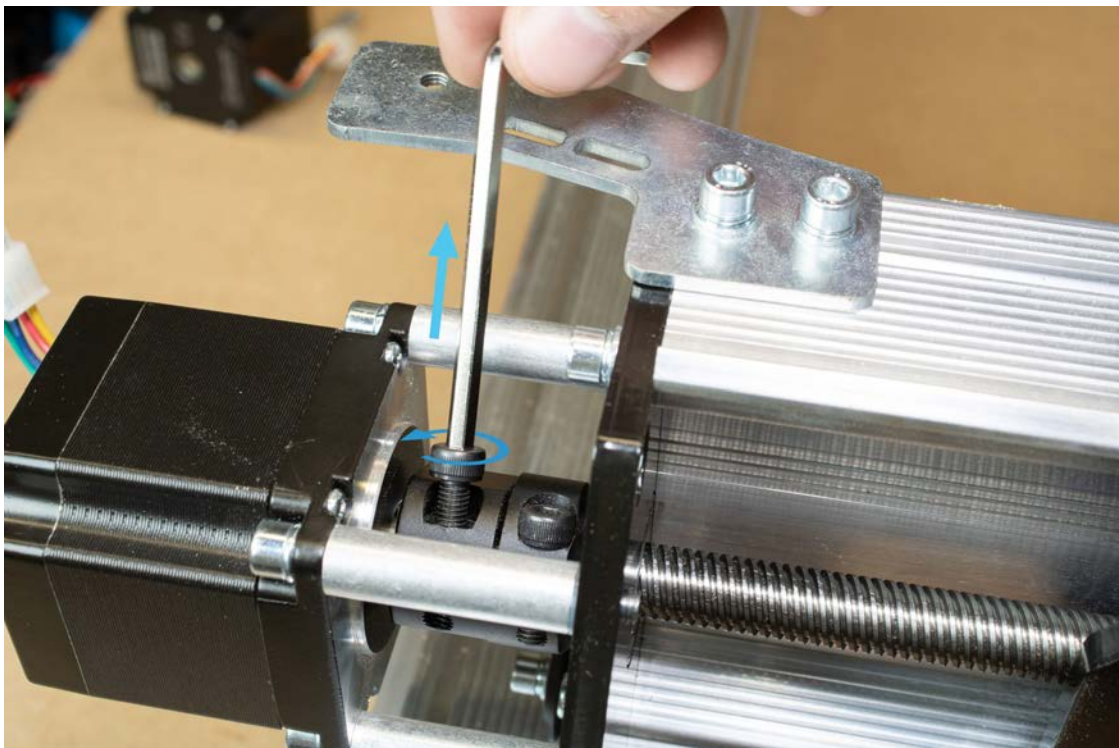

Pass an allen key through this hole of the removed bolt to lock the coupler against the motor standoffs from rotating. Alternatively, a small screwdriver, bolt, or rod can be passed through instead.

Locking the lead screw from rotating will allow for easier installation of the T8 Clamping nut at the opposite side.

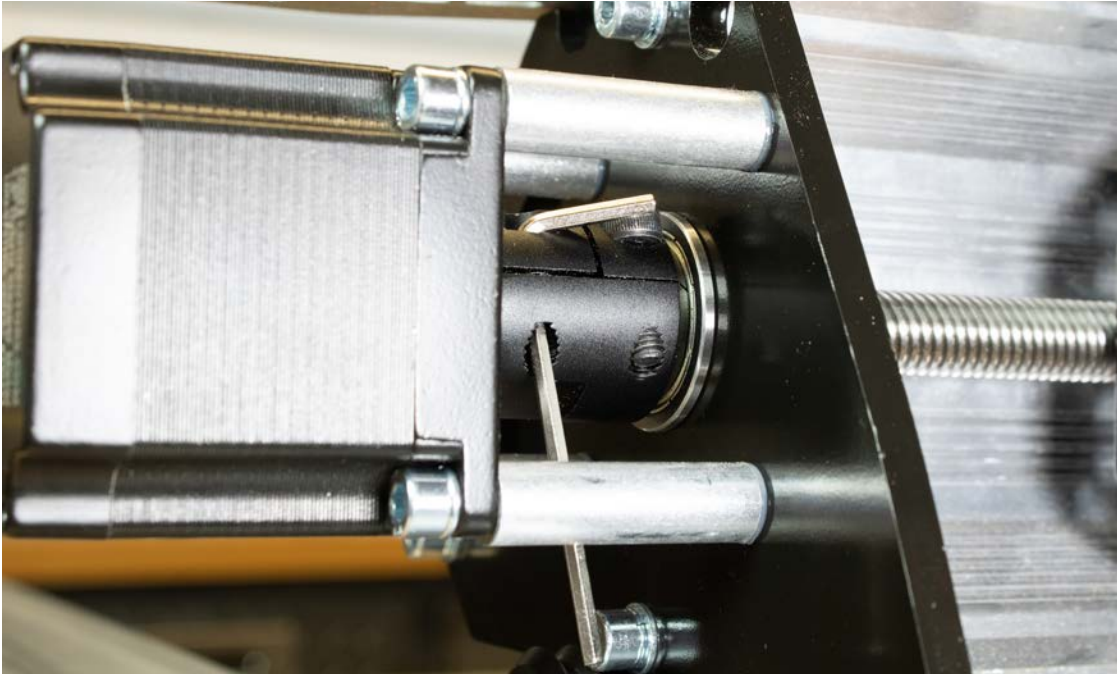

At the opposite side of the lead screw on the right Y-gantry plate, slide a flange bearing over the lead screw and into the Y-gantry plate.



Remove any screwdrivers, allen keys, or bolts from the coupler on the opposite side to allow the coupler and lead screw to freely rotate. Then reinstall the M5-16mm bolt into the motor side of the coupler and tighten this using the allen key handle - this should be tightened very tight.

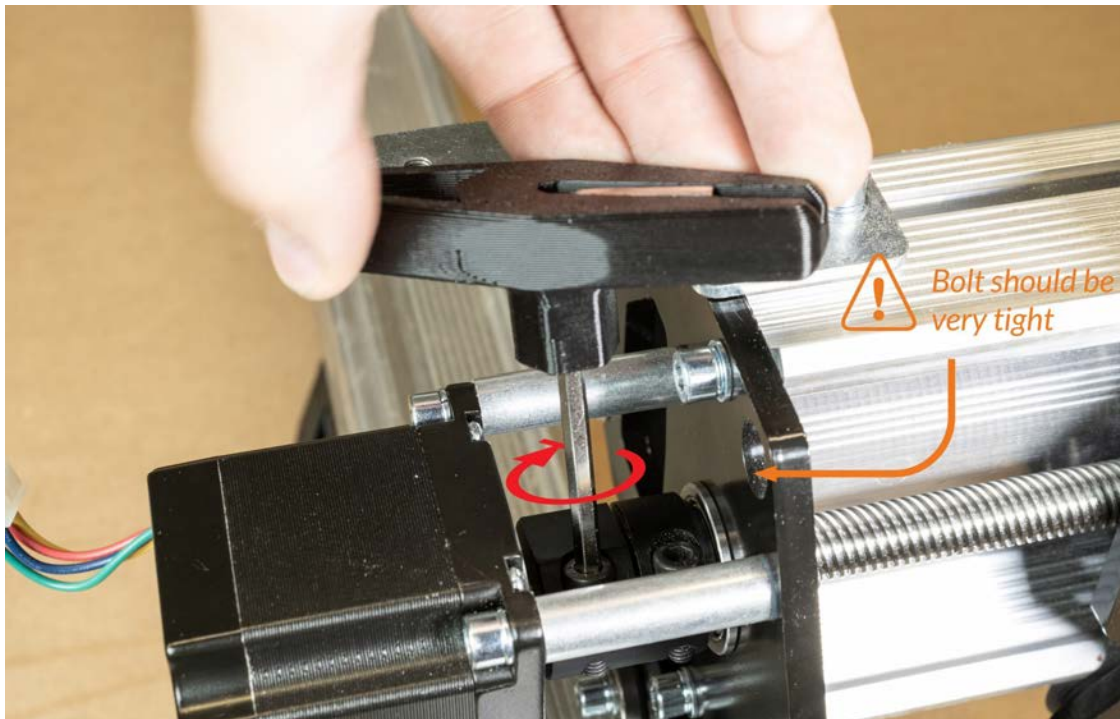

[Continue to page 46 in main LongMill MK2.5 assembly manual - 'Z-axis Stepper motor mounting'](#)

Section F - Cable extension installation

Connecting and routing cables

Parts Needed:



Motor cable extension

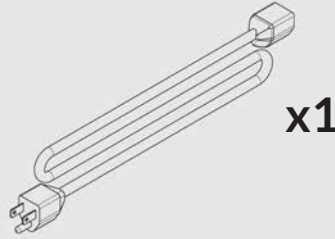

Router power cable extension



Limit switch cable extension
(If applicable)

Loosen the bolt mounting the X-axis drag chain onto the X-axis rail and slide this end link roughly 10" towards the middle of the rail. Re-tighten this mounting bolt after.

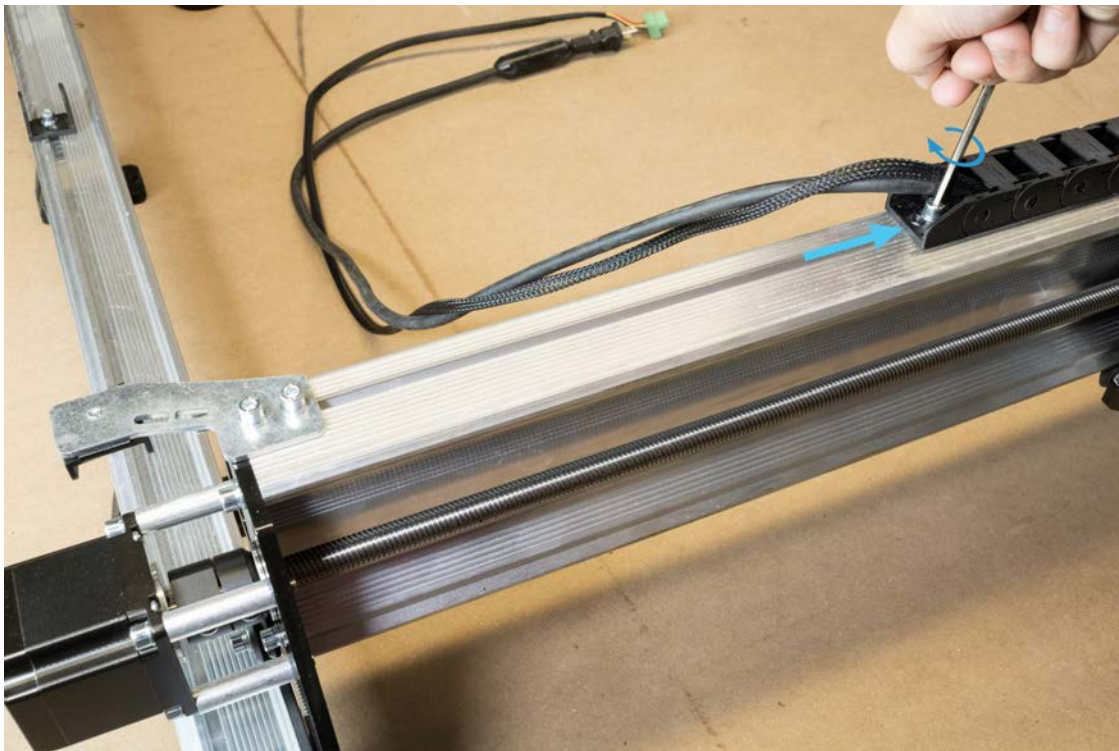

Only applicable if installing the inductive sensor kit as well:

If you purchased the inductive sensor add-on kit, you'll want to install the Z-axis limit switch now. Grab the limit switch cable extension from the EX drag chain & cable box, as well as one of the three inductive sensors from within the kit.

Route one inductive sensor cable through the X-axis drag chain, leaving some slack at the sensor for mounting the sensor later. Install the included limit switch extension cable as shown below to extend this cable. The excess cable length will be bundled with the Z-axis motor cable and router power cable in the next section.

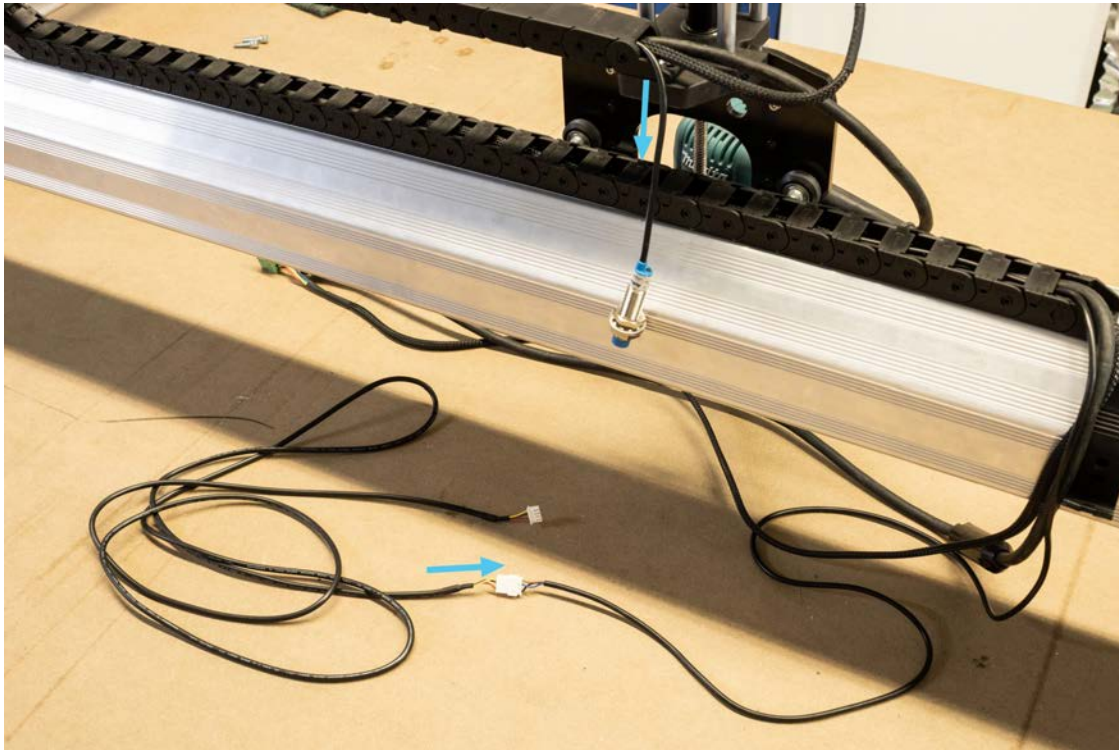

Grab the router power extension cable from the EX drag chain & cable box.

Connect the router power extension cable to the router power cord and Z-axis motor cable coming out from the X-axis drag chain. If you have the z-axis limit switch extension cable, connect that now.

The image below shows the old style of motor cables, you won't have this connection type with the longer motor cable.



Grab a motor cable and connect it to the X-axis motor.

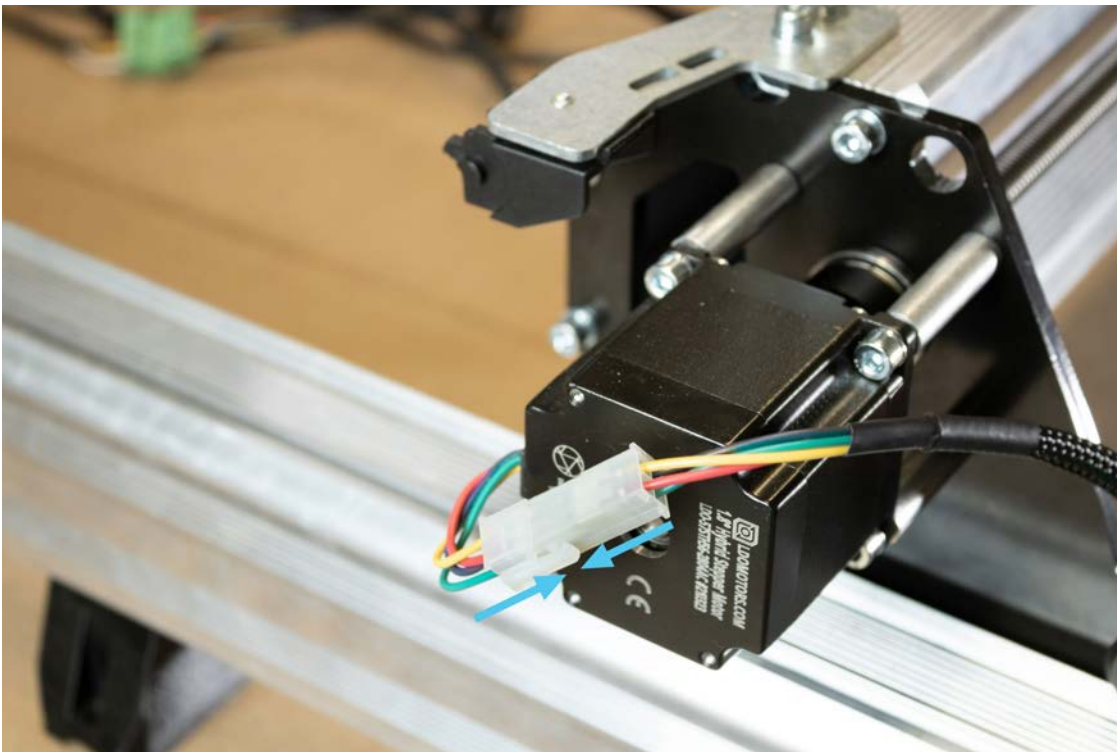

Begin routing the extension cables and X-axis motor cable into the shorter Y-axis drag chain. Fit these cables underneath the drag chain mount. Allow the connectors to sit outside of the Y-axis drag chain as shown. This excess bundling of cable will be organized neatly in the next step.

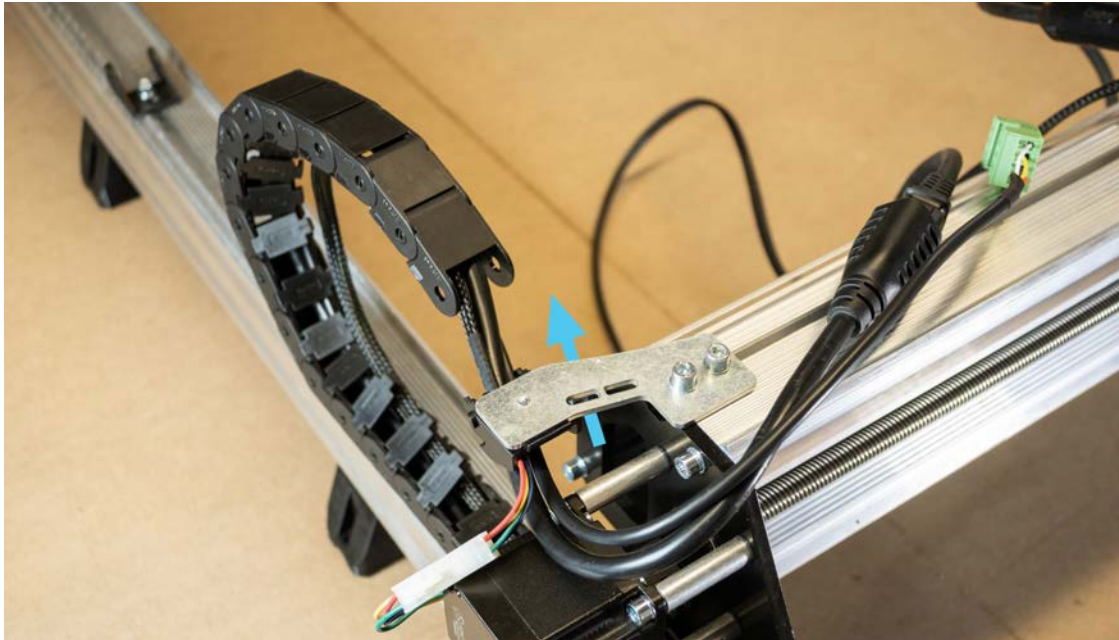

Secure the cables inside the drag chain by re-clipping each clip, then attach the drag chain onto the start and end links mounted on the machine.

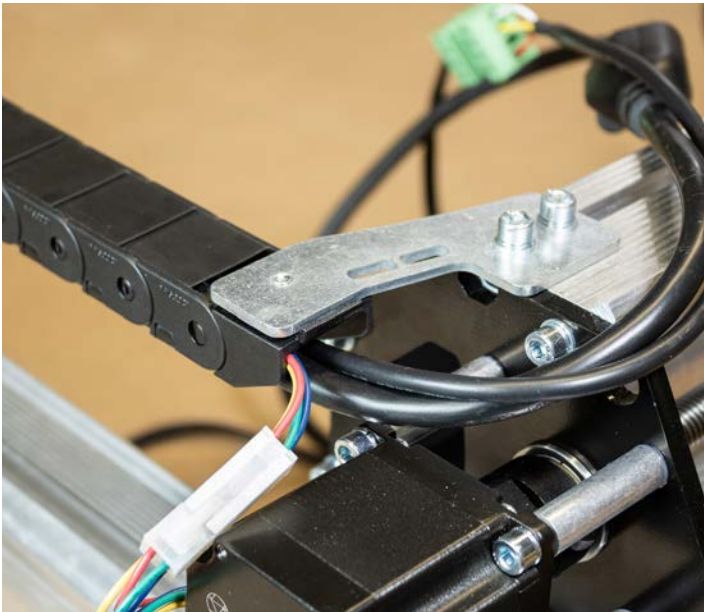

Organizing excess cable lengths

Parts Needed:



x2

MK2 cable hanger

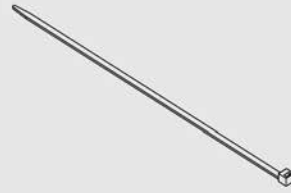

x2

8" Zip tie

Grab the two 'cable hangers' from the MK2.5 EX hardware box. Align the clip portion of these into the T-slot on the X-rail and press directly downwards firmly to clip these in place. These are installed between the X-axis drag chain end link and the steel drag chain mount as shown.

Should you need to unclip these hangers for any minor adjustments, pull the bottom edge of the hanger upwards to rotate and unclip from the T-slot.



Get two zip ties from the MK2.5 EX hardware bag and insert these into the lower hole in each of the drag chain mounts.

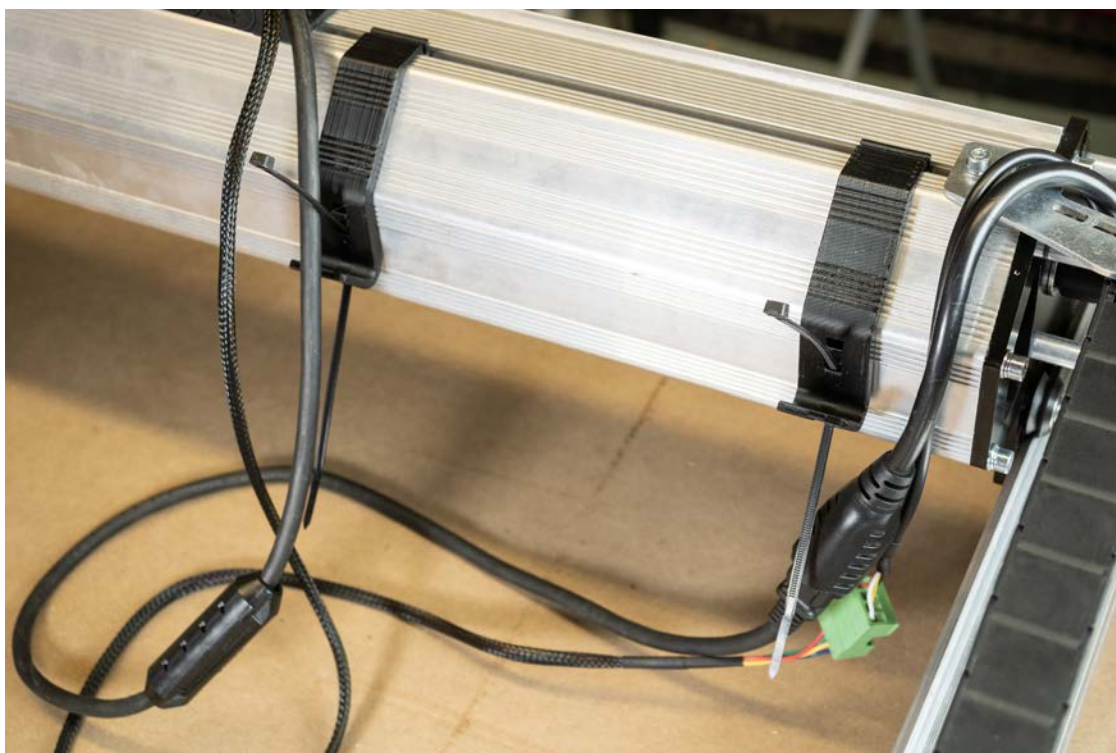
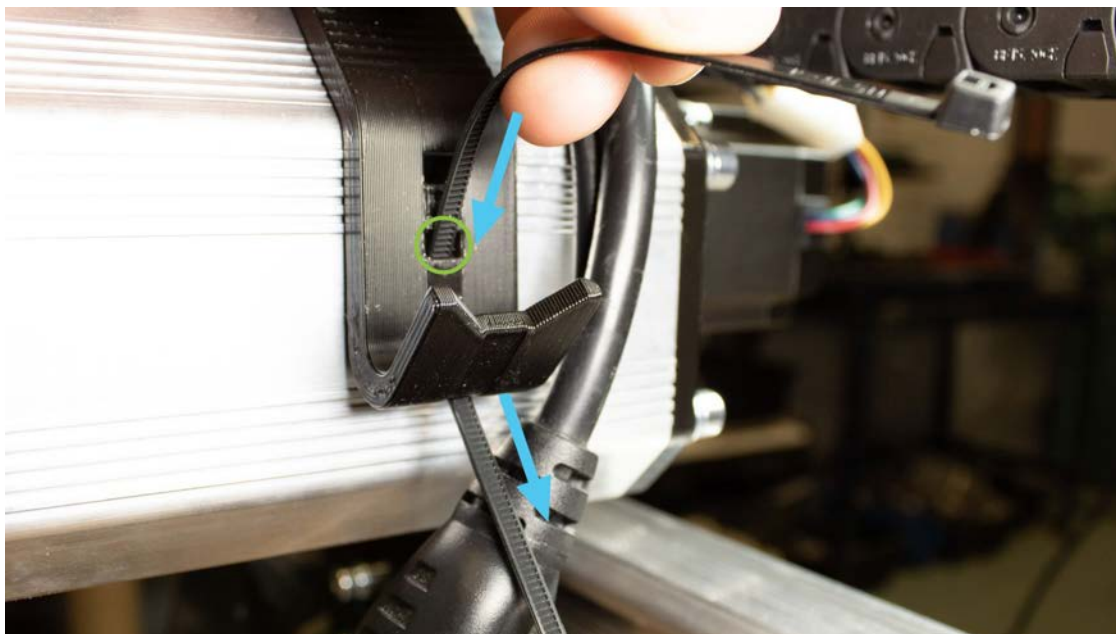

Straighten out the excess cabling into one bunch, then fold this in half.



The folded bunch of excess cables can then be secured into both cable hangers. Tighten the two zip ties at each hanger. Trim the excess length from the zip ties once finished.

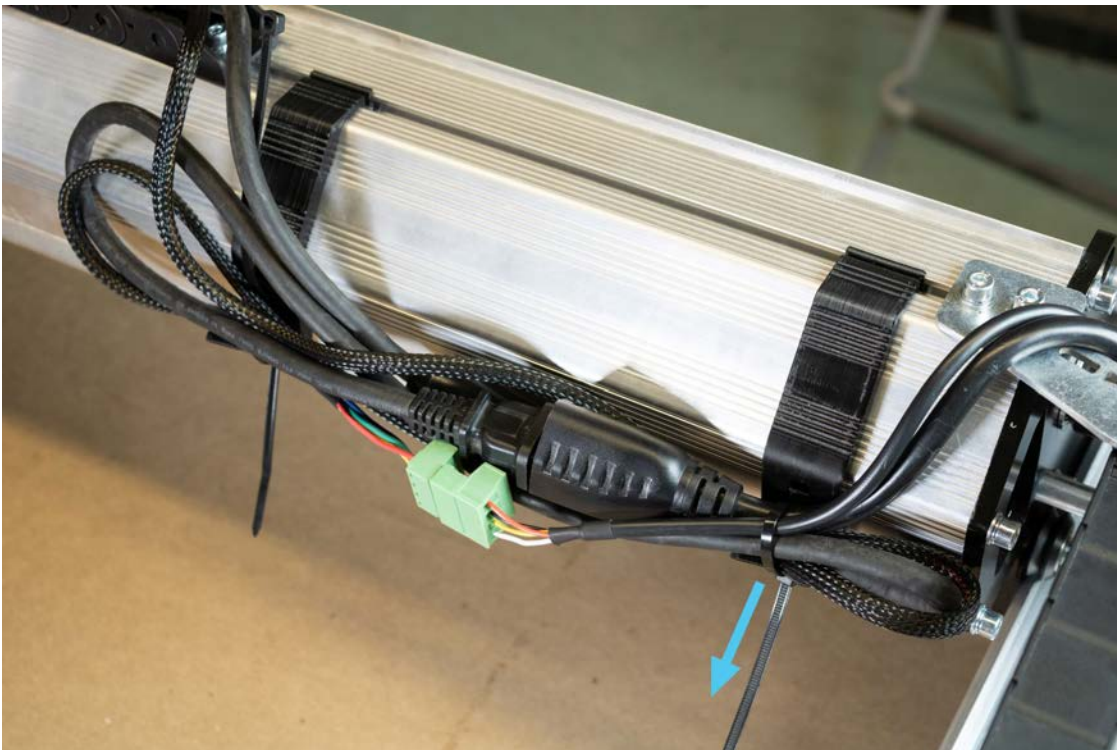

Adjust any of the cabling so it fits well within these two hangers and nothing hangs below the X-axis rail, then tighten the zip ties fully. You can adjust the position of the two cable hangers before tightening these zip ties for good. In any case, extra zip ties are provided just in case you'd like to come back and make any adjustments.

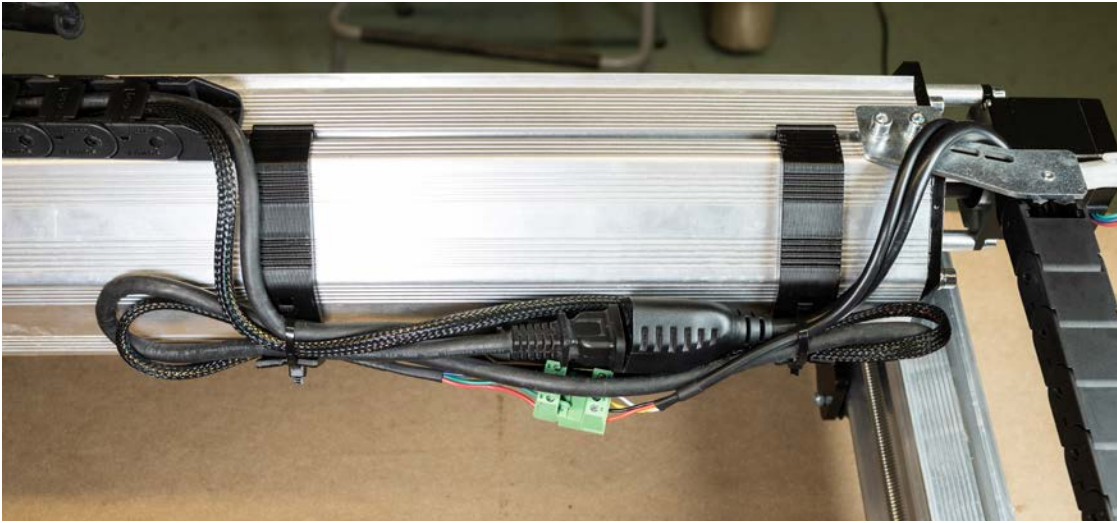

Lastly, plug in the cables for the motors on the two Y-axis NEMA 23 stepper motors.

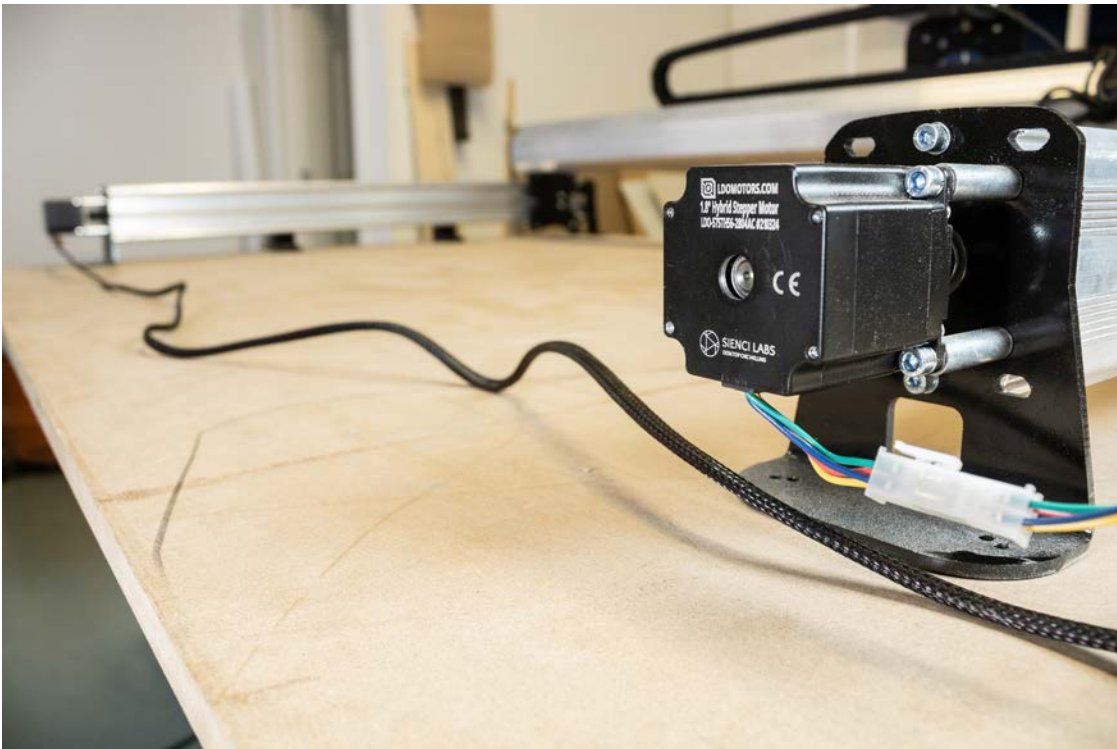

Bring the cables around to the left of the machine so they're now all bundled together (pictured). This is the last step specific to the 48x30 size LongMill MK2.5, you'll be plugging the motors cables into the control box shortly but otherwise the machine wiring is now complete!

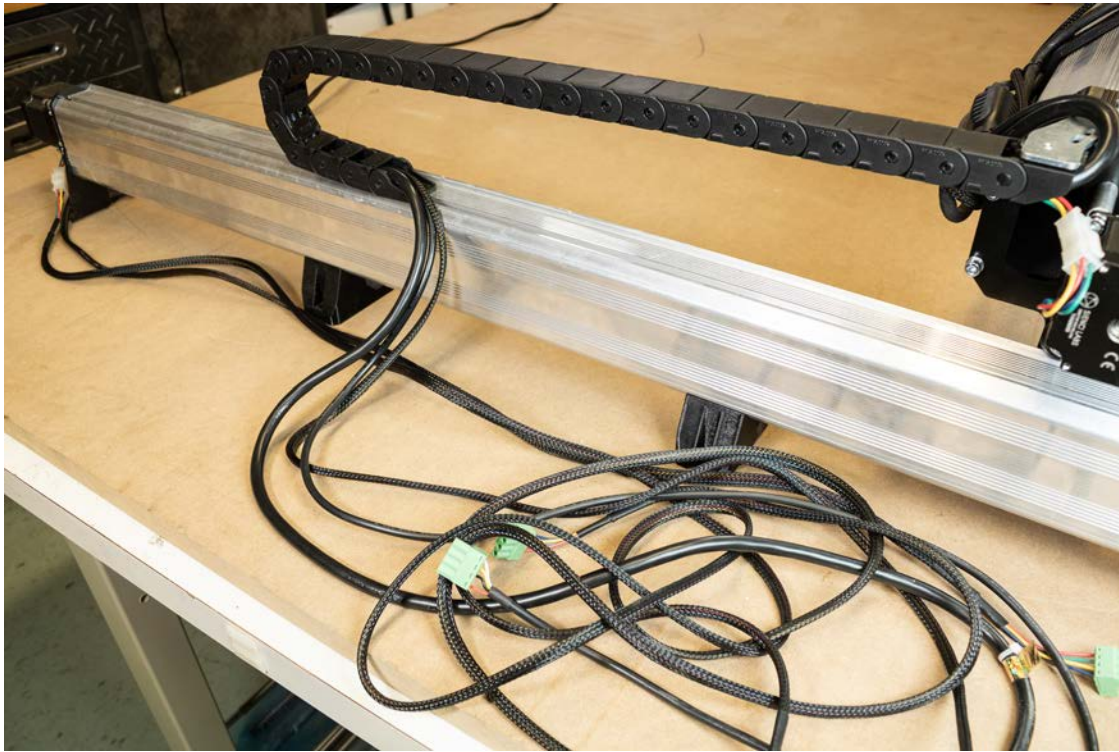

[Continue to page 60](#) in main LongMill MK2.5 assembly manual - '[Checks & first moves](#)'