

# gControl

## AltMill & LongMill Mounting Instructions

Note: Applicable only to gControl kits  
utilizing plastic mounting base

### 2. Install Post & Mounting Caps

4x M5-50mm Socket Head  
Cap Screws

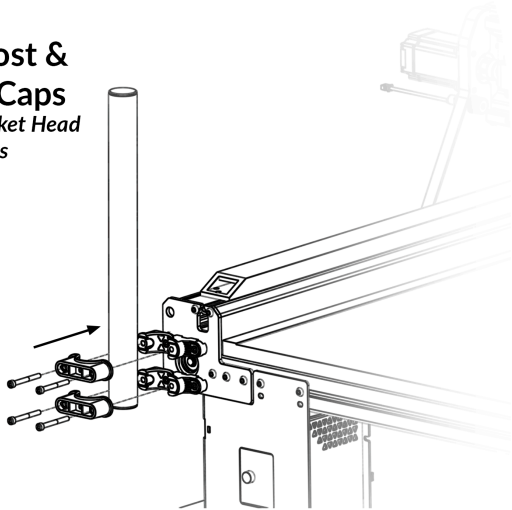

### 4. Install Mounting Plate

4x M4-8mm Button Head  
Screws

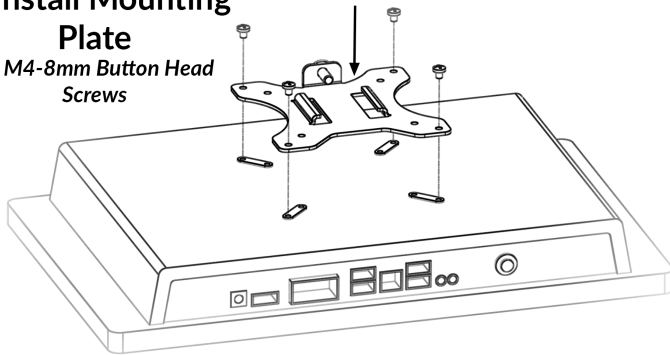

### 6. Fasten Locking Screw to Arm Mount

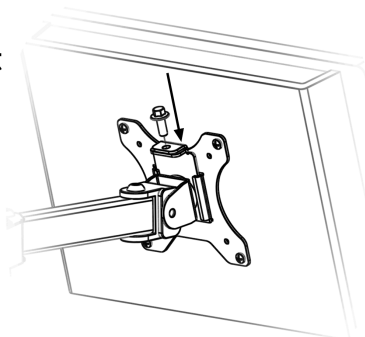

### 1. Install Plastic Mounting Base

4x M5-10mm Socket Head Cap  
Screws

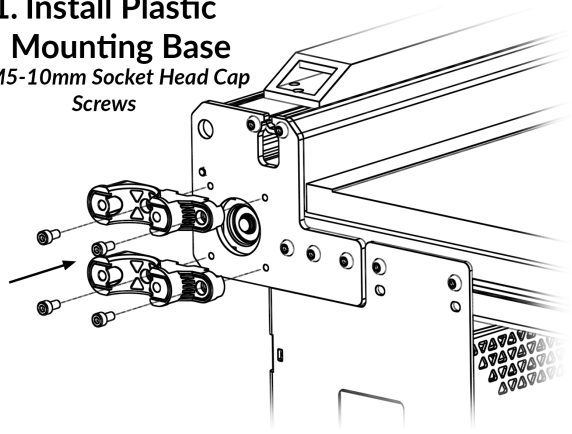

### 3. Install Arm Link

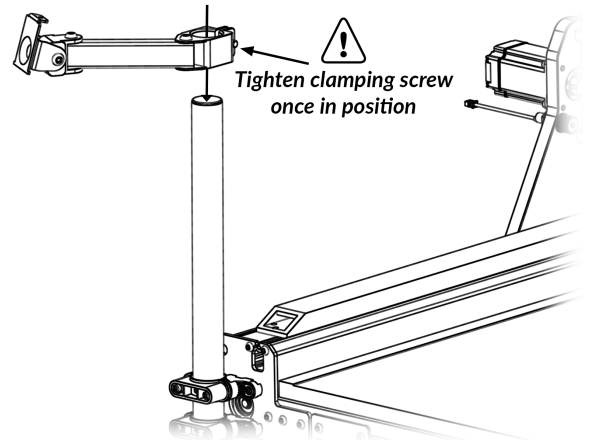

### 5. Mount Panel to Arm

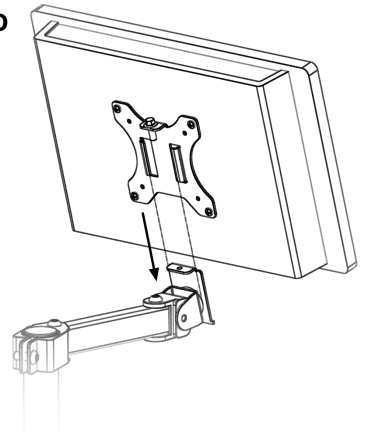

### 7. Plug In Power & USB Cable

